



HCF4094B

8 STAGE SHIFT AND STORE BUS REGISTER WITH 3-STATE OUTPUTS

- 3- STATE PARALLEL OUTPUTS FOR CONNECTION TO COMMON BUS
- SEPARATE SERIAL OUTPUTS SYNCHRONOUS TO BOTH POSITIVE AND NEGATIVE CLOCK EDGES FOR CASCADING
- MEDIUM SPEED OPERATION 5MHz at 10V
- QUIESCENT CURRENT SPECIFIED UP TO 20V
- STANDARDIZED SYMMETRICAL OUTPUT CHARACTERISTICS
- 5V, 10V AND 15V PARAMETRIC RATINGS
- INPUT LEAKAGE CURRENT
 $I_l = 100\text{nA (MAX) AT } V_{DD} = 18\text{V } T_A = 25^\circ\text{C}$
- 100% TESTED FOR QUIESCENT CURRENT
- MEETS ALL REQUIREMENTS OF JEDEC JESD13B "STANDARD SPECIFICATIONS FOR DESCRIPTION OF B SERIES CMOS DEVICES"

DESCRIPTION

The HCF4094B is a monolithic integrated circuit fabricated in Metal Oxide Semiconductor technology available in DIP and SOP packages. The HCF4094B is an 8 stages serial shift register having a storage latch associated with each stage for strobing data from the serial input to parallel buffered 3-state outputs. The parallel outputs may be connected directly to common bus lines. Data

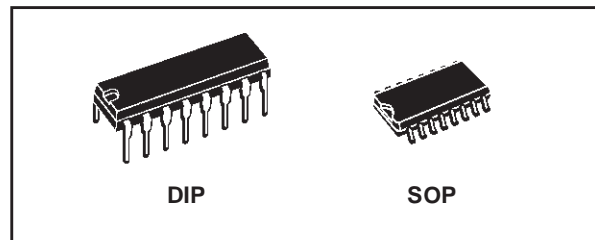

ORDER CODES

PACKAGE	TUBE	T & R
DIP	HCF4094BEY	
SOP	HCF4094BM1	HCF4094M013TR

is shifted on positive clock transition. The data in each shift register stage is transferred to the storage register when the STROBE input is high. Data in the storage register appears at the outputs whenever the OUTPUT-ENABLE signal is high. Two serial outputs are available for cascading a number of HCF4094B devices. Data is available at the Q_S serial output terminal on positive clock edges to allow for high speed operation in cascaded system in which the clock rise time is fast. The same serial information, available at the Q'_S terminal on the next negative clock edge, provides a means for cascading HCF4094B devices when the clock rise time is slow.

PIN CONNECTION

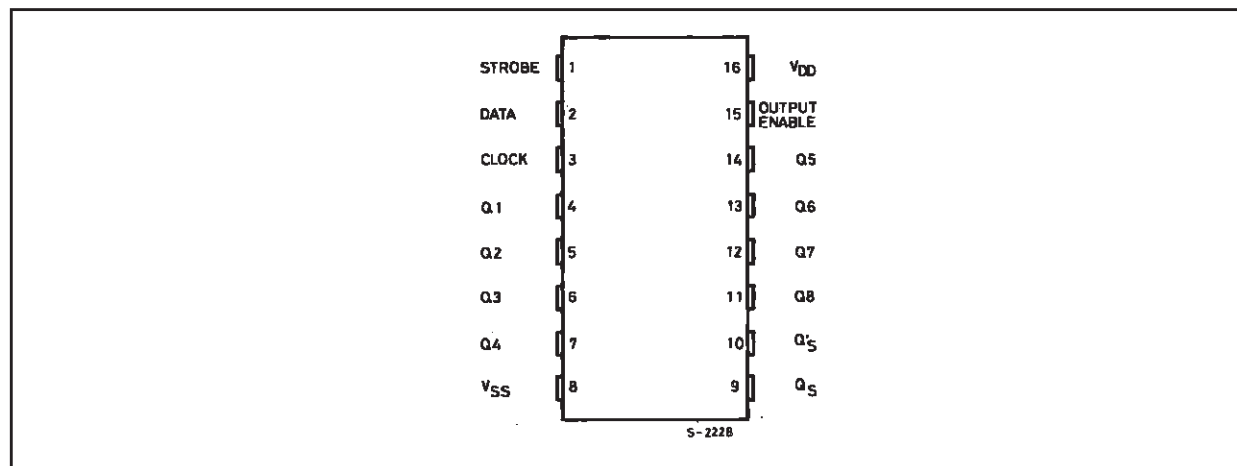

INPUT EQUIVALENT CIRCUIT

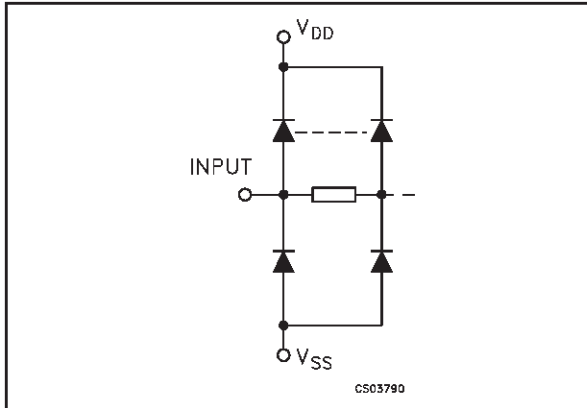

PIN DESCRIPTION

PIN No	SYMBOL	NAME AND FUNCTION
2	DATA	Data Input
1	STROBE	Strobe Input
3	CLOCK	Clock Input
9, 10	Q _S , Q' _S	Serial Outputs
4, 5, 6, 7, 14, 13, 12, 11	Q1 to Q8	Parallel Outputs
15	OUTPUT ENABLE	Output Enable Input
8	V _{SS}	Negative Supply Voltage
16	V _{DD}	Positive Supply Voltage

FUNCTIONAL DIAGRAM

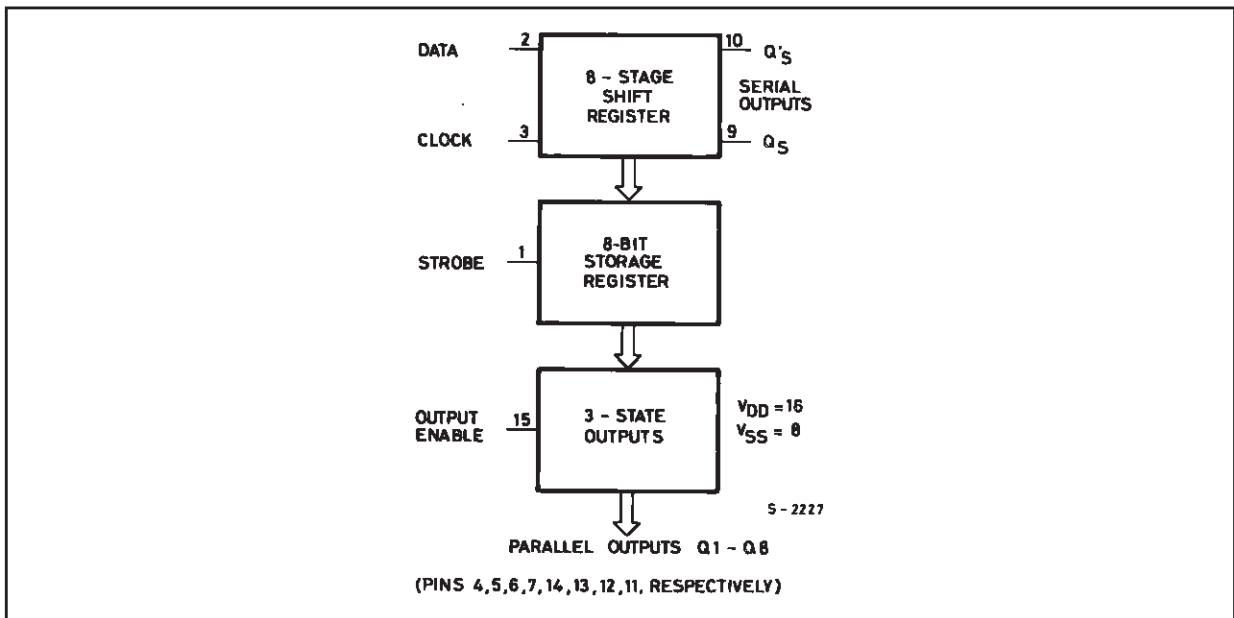

TRUTH TABLE

CLOCK	OUTPUTS ENABLE	STROBE	DATA	PARALLEL OUTPUTS		SERIAL OUTPUTS	
				Q ₁	Q _n	Q' _S	Q _S
	L	X	X	OC	OC	Q7	No Change
	L	X	X	OC	OC	No Change	Q7
	H	L	X	No Change	No Change	Q7	No Change
	H	H	L	L	Q _n - 1	Q7	No Change
	H	H	H	H	Q _n - 1	Q7	No Change
	H	H	H	No Change	No Change	No Change	Q7

X : Don't Care

OC : Open Circuit

* At the positive clock edge information on the 7th shift register stage is transferred to the 8th register stage and the Q_S output.

LOGIC DIAGRAM

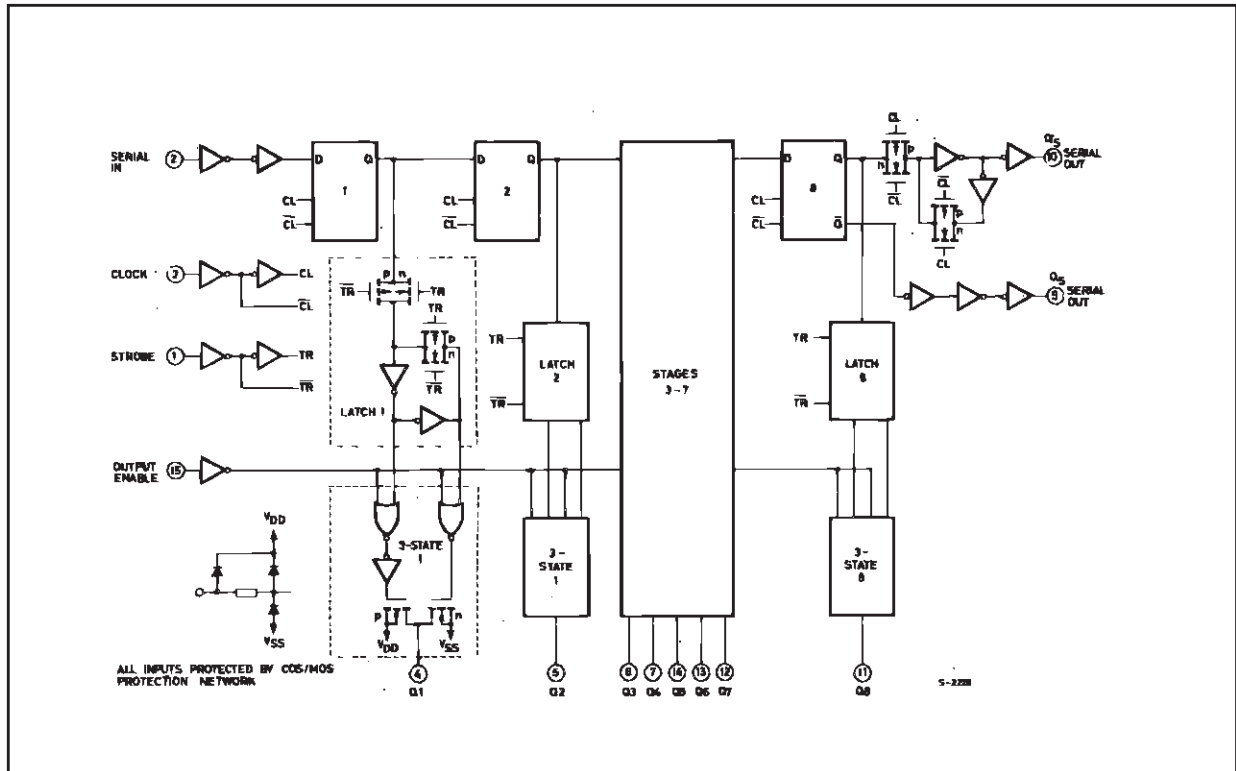

TIMING CHART

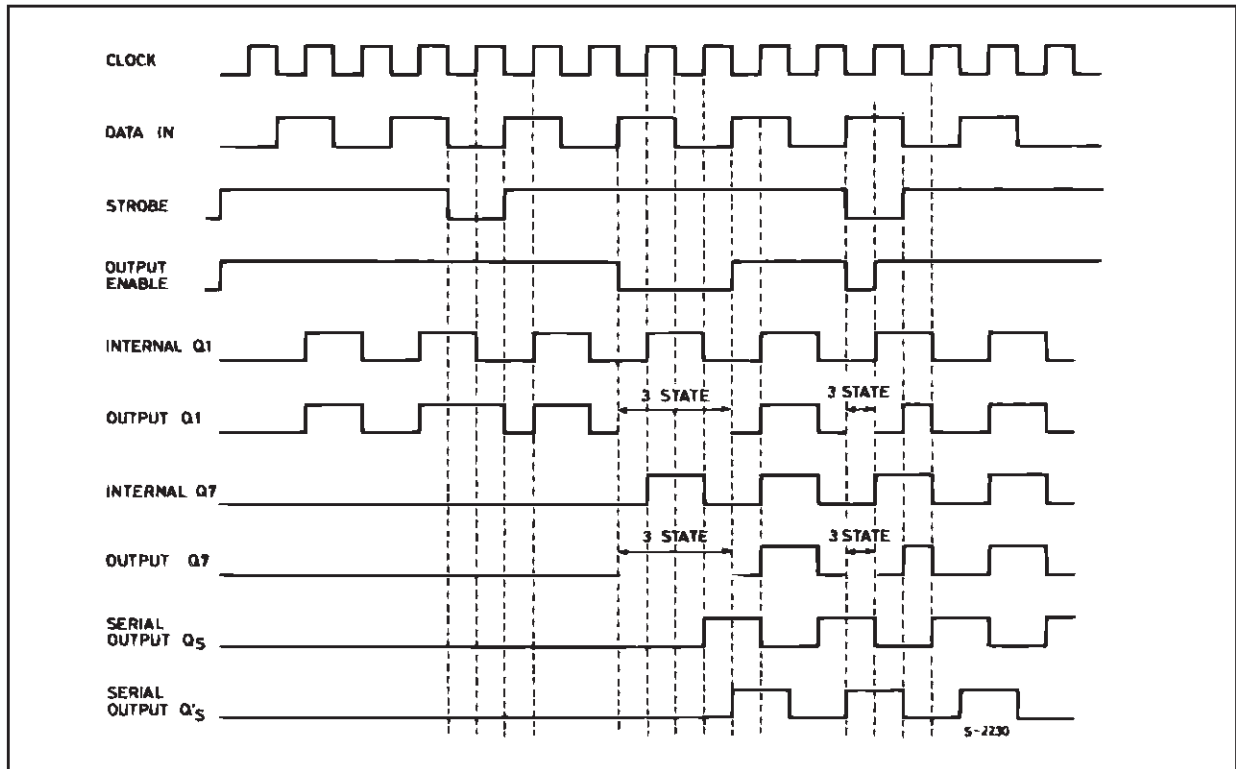

ABSOLUTE MAXIMUM RATINGS

Symbol	Parameter	Value	Unit
V_{DD}	Supply Voltage	-0.5 to +22	V
V_I	DC Input Voltage	-0.5 to $V_{DD} + 0.5$	V
I_I	DC Input Current	± 10	mA
P_D	Power Dissipation per Package	200	mW
	Power Dissipation per Output Transistor	100	mW
T_{op}	Operating Temperature	-55 to +125	°C
T_{stg}	Storage Temperature	-65 to +150	°C

Absolute Maximum Ratings are those values beyond which damage to the device may occur. Functional operation under these conditions is not implied.

All voltage values are referred to V_{SS} pin voltage.

RECOMMENDED OPERATING CONDITIONS

Symbol	Parameter	Value	Unit
V_{DD}	Supply Voltage	3 to 20	V
V_I	Input Voltage	0 to V_{DD}	V
T_{op}	Operating Temperature	-55 to 125	°C

DC SPECIFICATIONS

Symbol	Parameter	Test Condition				Value						Unit	
		V _I (V)	V _O (V)	I _O (μ A)	V _{DD} (V)	T _A = 25°C			-40 to 85°C		-55 to 125°C		
						Min.	Typ.	Max.	Min.	Max.	Min.		Max.
I _L	Quiescent Current	0/5			5		0.04	5		150		150	μ A
		0/10			10		0.04	10		300		300	
		0/15			15		0.04	20		600		600	
		0/20			20		0.08	100		3000		3000	
V _{OH}	High Level Output Voltage	0/5		<1	5	4.95			4.95		4.95		V
		0/10		<1	10	9.95			9.95		9.95		
		0/15		<1	15	14.95			14.95		14.95		
V _{OL}	Low Level Output Voltage	5/0		<1	5		0.05			0.05		0.05	V
		10/0		<1	10		0.05			0.05		0.05	
		15/0		<1	15		0.05			0.05		0.05	
V _{IH}	High Level Input Voltage		0.5/4.5	<1	5	3.5			3.5		3.5		V
			1/9	<1	10	7			7		7		
			1.5/13.5	<1	15	11			11		11		
V _{IL}	Low Level Input Voltage		4.5/0.5	<1	5			1.5		1.5		1.5	V
			9/1	<1	10			3		3		3	
			13.5/1.5	<1	15			4		4		4	
I _{OH}	Output Drive Current	0/5	2.5	<1	5	-1.36	-3.2		-1.1		-1.1		mA
		0/5	4.6	<1	5	-0.44	-1		-0.36		-0.36		
		0/10	9.5	<1	10	-1.1	-2.6		-0.9		-0.9		
		0/15	13.5	<1	15	-3.0	-6.8		-2.4		-2.4		
I _{OL}	Output Sink Current	0/5	0.4	<1	5	0.44	1		0.36		0.36		mA
		0/10	0.5	<1	10	1.1	2.6		0.9		0.9		
		0/15	1.5	<1	15	3.0	6.8		2.4		2.4		
I _I	Input Leakage Current	0/18	Any Input		18		$\pm 10^{-5}$	± 0.1		± 1		± 1	μ A
I _{OH} , I _{OL}	3-State Output Leakage Current	0/18	0/18		18		$\pm 10^{-4}$	± 0.4		± 12		± 12	μ A
C _I	Input Capacitance		Any Input				5	7.5					pF

The Noise Margin for both "1" and "0" level is: 1V min. with V_{DD}=5V, 2V min. with V_{DD}=10V, 2.5V min. with V_{DD}=15V

HCF4094B

DYNAMIC ELECTRICAL CHARACTERISTICS ($T_{amb} = 25^{\circ}\text{C}$, $C_L = 50\text{pF}$, $R_L = 200\text{K}\Omega$, $t_r = t_f = 20\text{ ns}$)

Symbol	Parameter	Test Condition		Value (*)			Unit
		V_{DD} (V)		Min.	Typ.	Max.	
t_{PLH} t_{PHL}	Propagation Delay Time (Clock to serial Output Q_S)	5			300	600	ns
		10			125	250	
		15			95	190	
t_{PLH} t_{PHL}	Propagation Delay Time (Clock to serial Output Q'_S)	5			230	460	ns
		10			110	220	
		15			75	150	
t_{PLH} t_{PHL}	Propagation Delay Time (Clock to Parallel Output)	5			420	840	ns
		10			195	390	
		15			135	270	
t_{PLH} t_{PHL}	Propagation Delay Time (Strobe to Parallel Output)	5			290	580	ns
		10			145	290	
		15			100	200	
t_{PZL} t_{PZH}	Propagation Delay Time Output Enable to Parallel Out : Output High to High Impedance	5			140	280	ns
		10			75	150	
		15			55	110	
t_{PHZ} t_{PLZ}	Propagation Delay Time Output Enable to Parallel Out : Output Low to High Impedance	5			225	450	ns
		10			95	190	
		15			70	140	
t_W	Strobe Pulse Width	5		200	100		ns
		10		80	40		
		15		70	35		
t_W	Clock Pulse Width	5		200	100		ns
		10		100	50		
		15		83	40		
t_{setup}	Data Setup Time	5		125	60		ns
		10		55	30		
		15		35	20		
t_{hold}	Minimum Hold Time	5		0	0	0	ns
		10		0	0	0	
		15		0	0	0	
t_{TLH} t_{THL}	Transition Time	5			100	200	ns
		10			50	100	
		15			40	80	
t_r t_f	Clock input Rise or Fall Time	5		15			μs
		10		5			
		15		5			
f_{max}	Maximum Clock Input Frequency	5		1.25	2.5		MHz
		10		2.5	5		
		15		3	6		

(*) Typical temperature coefficient for all V_{DD} value is 0.3 %/°C.

TYPICAL APPLICATION (REMOTE CONTROL HOLDING REGISTER)

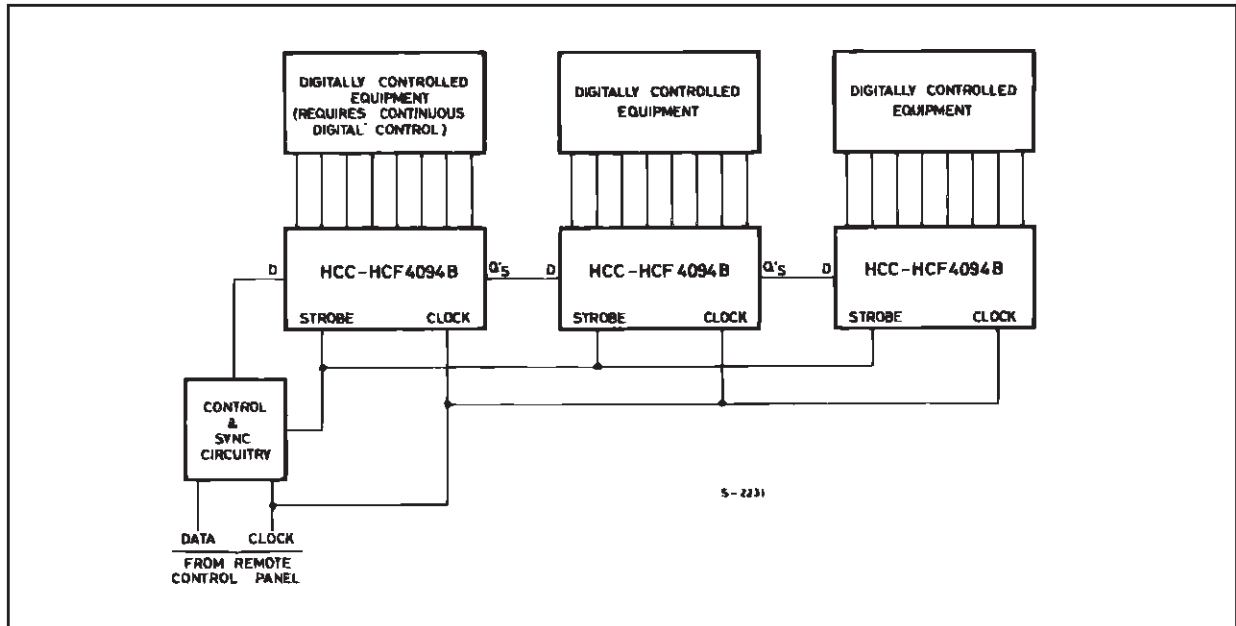

TEST CIRCUIT

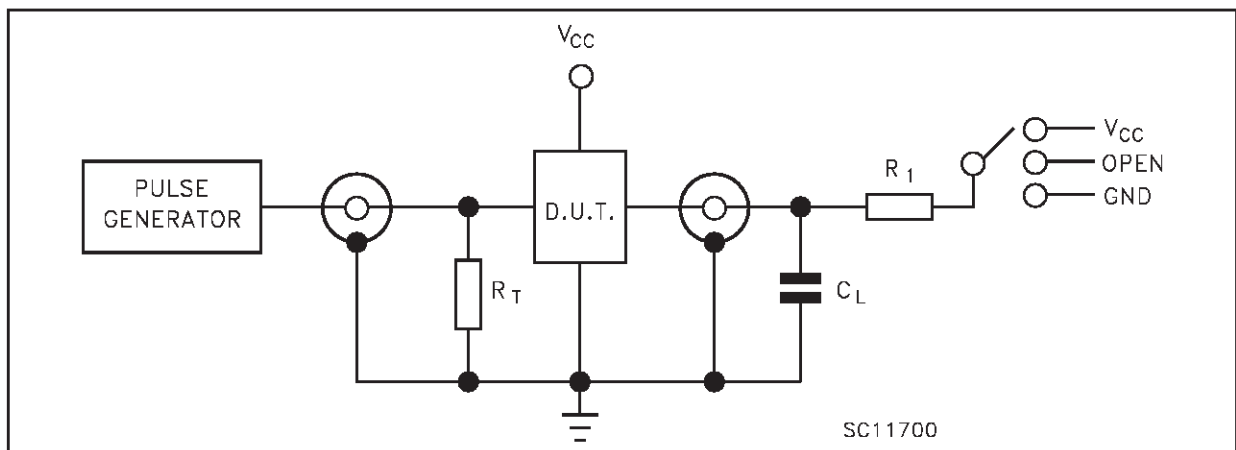

TEST	SWITCH
t_{PLH} , t_{PHL}	Open
t_{PZL} , t_{PLZ}	V_{CC}
t_{PZH} , t_{PHZ}	GND

$C_L = 50\text{pF}$ or equivalent (includes jig and probe capacitance)
 $R_L = 200\text{K}\Omega$
 $R_T = Z_{OUT}$ of pulse generator (typically 50Ω)

WAVEFORM 1 : PROPAGATION DELAY TIMES, PULSE WIDTH (CLOCK), SETUP AND HOLD TIME (DATA IN TO CLOCK) (f=1MHz; 50% duty cycle)

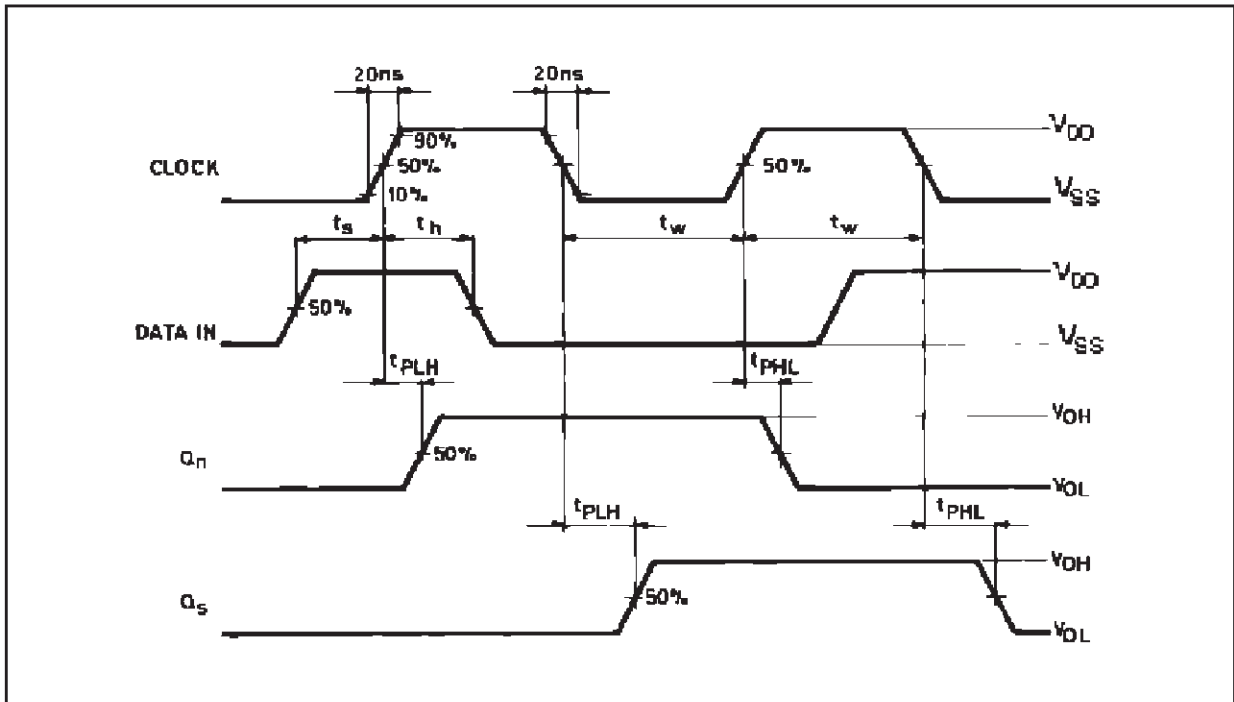

WAVEFORM 2 : PROPAGATION DELAY TIME, PULSE WIDTH (STROBE), SETUP AND HOLD TIME (STROBE TO CLOCK) (f=1MHz; 50% duty cycle)

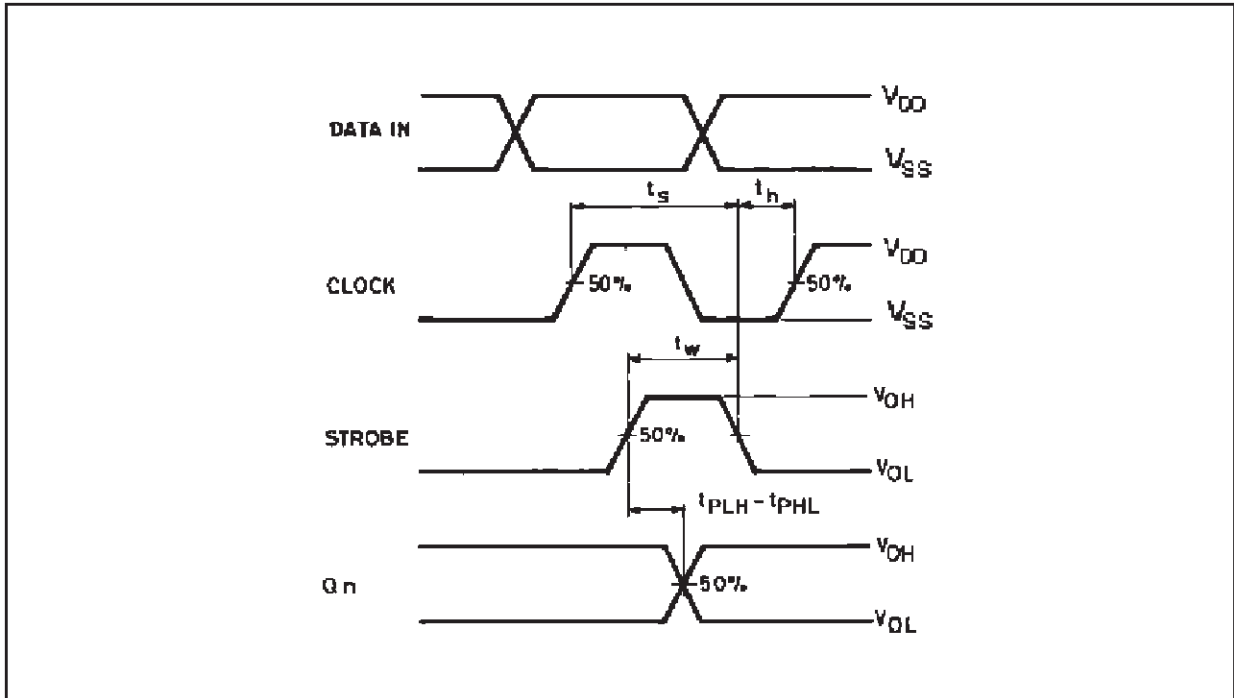

WAVEFORM 3 : OUTPUT ENABLE AND DISABLE TIME (f=1MHz; 50% duty cycle)

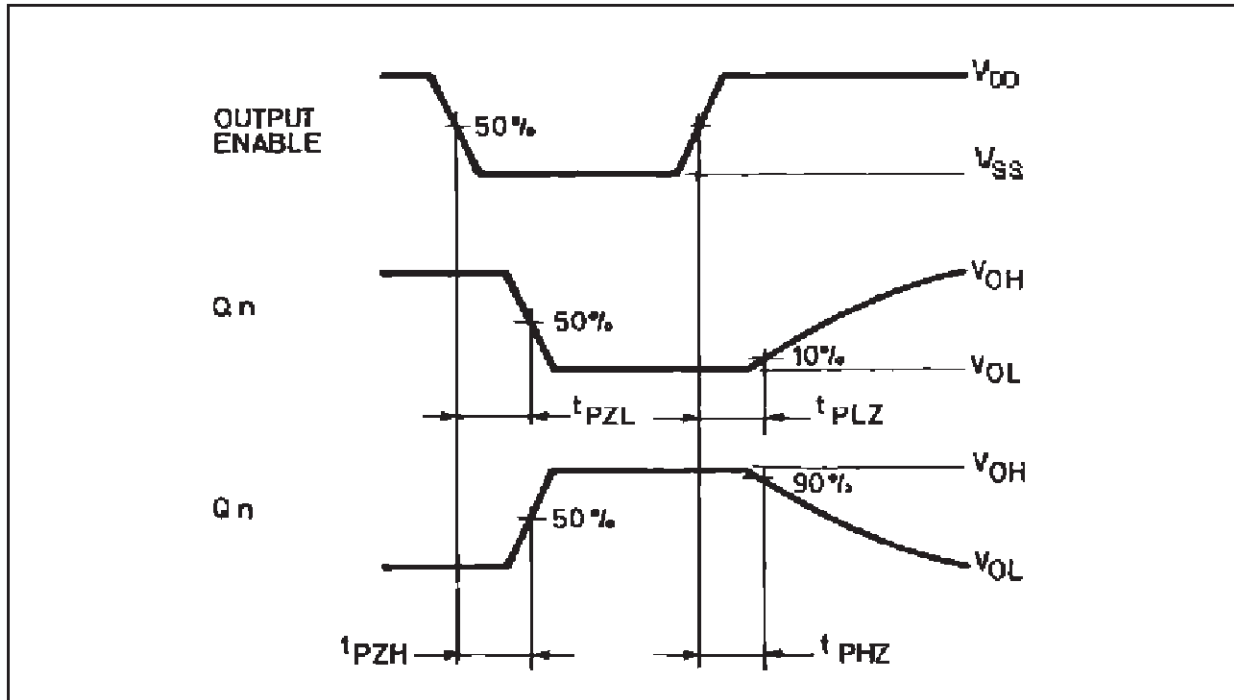

Plastic DIP-16 (0.25) MECHANICAL DATA

DIM.	mm.			inch		
	MIN.	TYP	MAX.	MIN.	TYP.	MAX.
a1	0.51			0.020		
B	0.77		1.65	0.030		0.065
b		0.5			0.020	
b1		0.25			0.010	
D			20			0.787
E		8.5			0.335	
e		2.54			0.100	
e3		17.78			0.700	
F			7.1			0.280
I			5.1			0.201
L		3.3			0.130	
Z			1.27			0.050

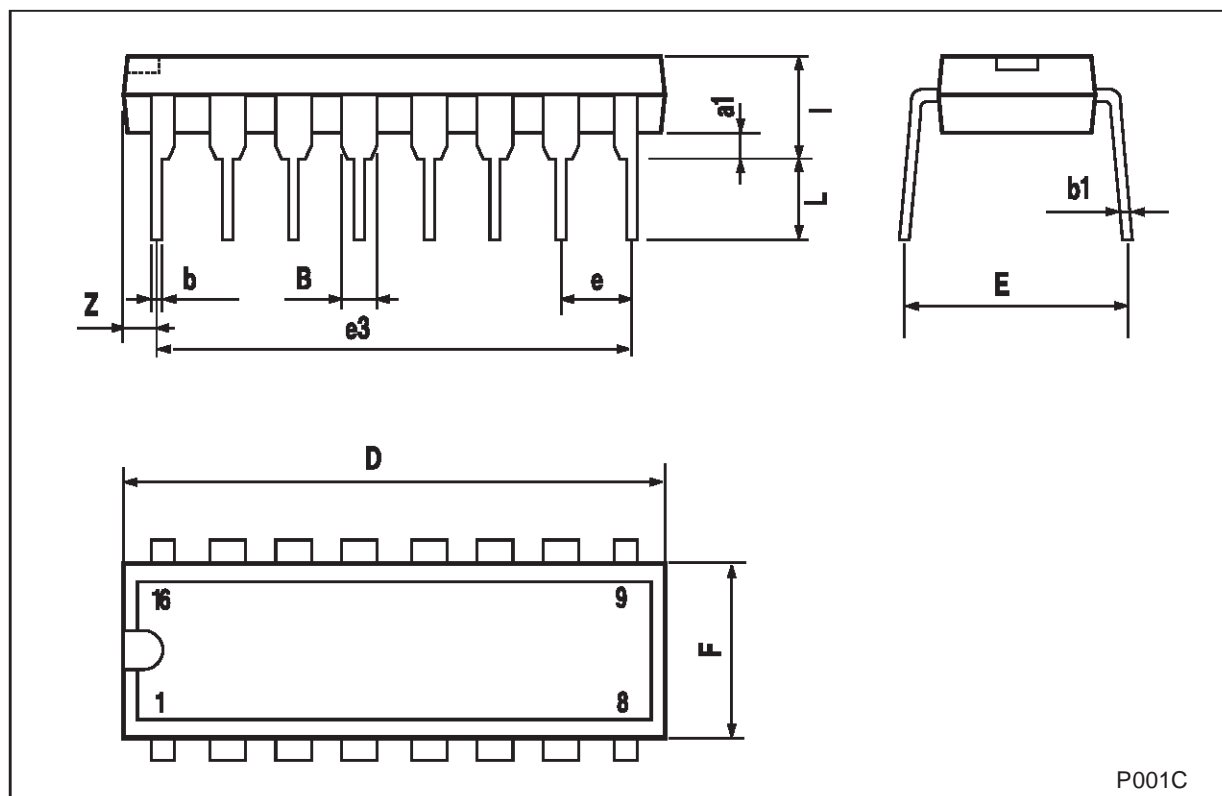

P001C

SO-16 MECHANICAL DATA

DIM.	mm.			inch		
	MIN.	TYP.	MAX.	MIN.	TYP.	MAX.
A			1.75			0.068
a1	0.1		0.2	0.003		0.007
a2			1.65			0.064
b	0.35		0.46	0.013		0.018
b1	0.19		0.25	0.007		0.010
C		0.5			0.019	
c1	45° (typ.)					
D	9.8		10	0.385		0.393
E	5.8		6.2	0.228		0.244
e		1.27			0.050	
e3		8.89			0.350	
F	3.8		4.0	0.149		0.157
G	4.6		5.3	0.181		0.208
L	0.5		1.27	0.019		0.050
M			0.62			0.024
S	8° (max.)					

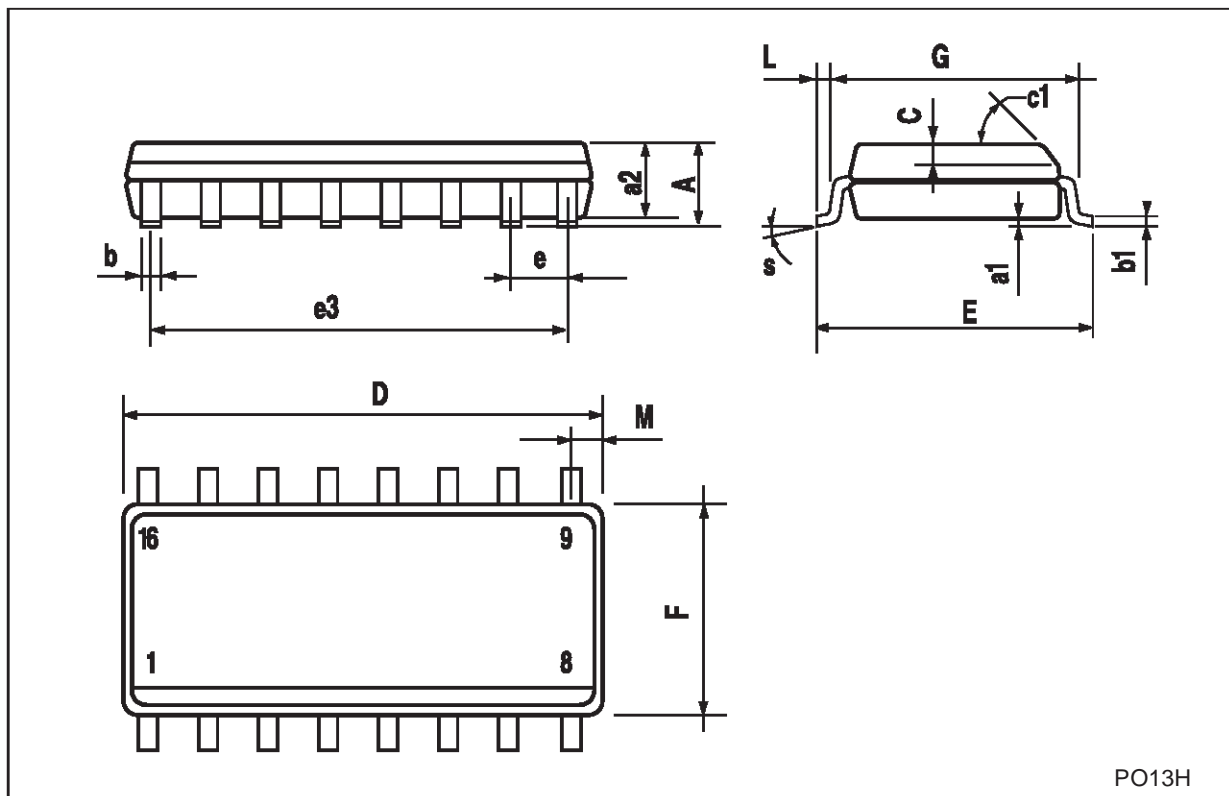

PO13H

Information furnished is believed to be accurate and reliable. However, STMicroelectronics assumes no responsibility for the consequences of use of such information nor for any infringement of patents or other rights of third parties which may result from its use. No license is granted by implication or otherwise under any patent or patent rights of STMicroelectronics. Specifications mentioned in this publication are subject to change without notice. This publication supersedes and replaces all information previously supplied. STMicroelectronics products are not authorized for use as critical components in life support devices or systems without express written approval of STMicroelectronics.

© The ST logo is a registered trademark of STMicroelectronics

© 2001 STMicroelectronics - Printed in Italy - All Rights Reserved
STMicroelectronics GROUP OF COMPANIES

Australia - Brazil - China - Finland - France - Germany - Hong Kong - India - Italy - Japan - Malaysia - Malta - Morocco
Singapore - Spain - Sweden - Switzerland - United Kingdom

© <http://www.st.com>