

Delivering high power output and excellent efficiency, Philips Semiconductors' Class D amplifier systems deliver much better audio performance than conventional AB audio amplifiers, making them ideal for multi-channel DVD and micro-sized audio systems, and high-end automotive applications.



#### Applications

- DVD-audio
- Mini- and micro-sized audio sets
- Multichannel speaker systems
- Booster for (sub)woofers
- Audio separates
- PA systems
- Car audio (application support)
- High-end TV

#### Features

- Power ranges from 20 to 150 W (up to 400 W with application support)
- Excellent power efficiency ( $\leq 95\%$ )
- Good EMC performance
- Excellent THD (0.01%)
- Symmetrical supply between 15 - 30 V
- Internal oscillator:
  - frequency adjustable between 200 and 600 kHz
  - can be overridden by an external clock (tracking option)
- Output stage protected against short circuit and overheating
- Simple SE and BTL applications
- Few external components
- Asymmetrical supply possible for BTL configurations (with application support)
- Powerpath ICs in Si17P and HSOP24 Power SMD package

## Class D audio amplifiers

### High efficiency, two-chip digital audio power amplifier systems

Already a leader in analog audio power amplifiers, Philips Semiconductors has created a new family of two-chip, Class D digital audio power amplifiers offering far greater efficiency and performance than current designs. Combining high power efficiency, power output and audio performance, they are suitable for a wide range of high-end audio applications. Efficiency is typically in excess of 95%, compared with 60% for Class AB amplifiers, so they waste less power (limiting the need for heat sinks); this allows smaller power supplies and significantly extends battery life for portable audio products.

Targeting consumer and automotive markets, the first two-chip solutions in the family consist of a controller (TDA8929) for generating digital input, and an amplifying power stage. Philips Semiconductors already has two power stages available for higher power applications, the TDA8926 (2 x 50 W, 8  $\Omega$ ) and TDA8927 (2 x 100 W, 4  $\Omega$ ); future single-chip devices in the Class D power amplifier family will include pin-compatible products for 2 x 15 W, 2 x 25 W and 2 x 50 W.

This new audio amplifier family uses Philips' unique SOI (Silicon on Insulator) fabrication process, delivering features such as low  $R_{DS(on)}$  which contribute to the family's high power efficiency. Component isolation, achieved with the oxide layer, prevents latch-up and low parasitic capacitances improve audio quality; also, SOI's inherent robustness provides protection from transient voltage spikes and fault conditions in automotive applications.

#### Class D amplification

Pulse Width Modulation (PWM) techniques allow Class D amplifiers to provide better efficiency than traditional, power-hungry Class A, Class B and Class AB analog amplifiers. Essentially, PWM signals are applied to the power stage, which provides high output current capability. The resulting amplified signals are square waves of constant amplitude, which carry signal information in the width variance of the wave. Signal filtering at the output removes the high frequency carrier wave, passing audio information to the speakers.

# Controller and power amplifier stage

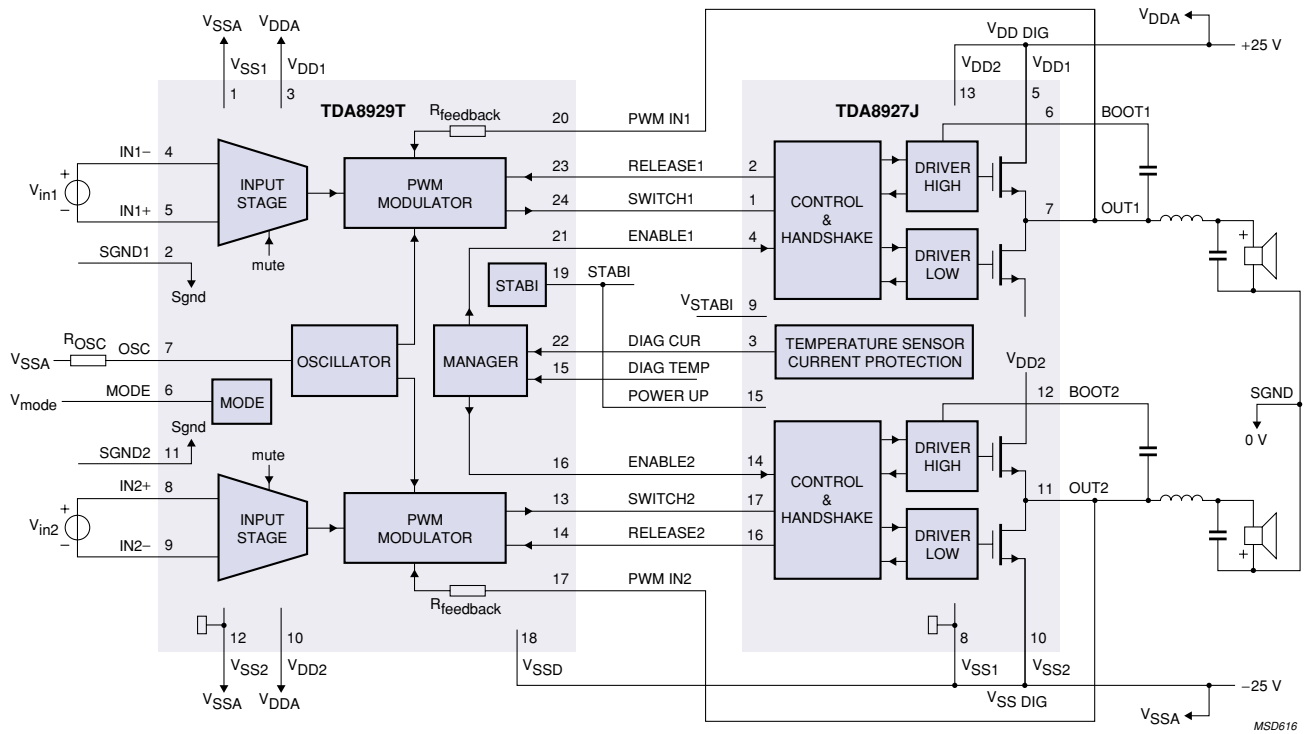

## Philips Semiconductors – a worldwide company

**Argentina:** see South America  
**Australia:** Tel. +61 2 9704 8141, Fax. +61 2 9704 8139  
**Austria:** Tel. +43 1 60 101 1248, Fax. +43 1 60 101 1210  
**Belarus:** Tel. +375 172 20 0733, Fax. +375 172 20 0773  
**Belgium:** see The Netherlands  
**Brazil:** see South America  
**Bulgaria:** Tel. +359 2 68 9211, Fax. +359 2 68 9102  
**Canada:** Tel. +1 800 234 7381, Fax. +1 800 943 0087  
**China/Hong Kong:** Tel. +852 2319 7888, Fax. +852 2319 7700  
**Colombia:** see South America  
**Czech Republic:** see Austria  
**Denmark:** Tel. +45 33 29 3333, Fax. +45 33 29 3905  
**Finland:** Tel. +358 9 615 800, Fax. +358 9 6158 0920  
**France:** Tel. +33 1 4728 6600, Fax. +33 1 4728 6638  
**Germany:** Tel. +49 40 2353 60, Fax. +49 40 2353 6300  
**Hungary:** Tel. +36 1 382 1700, Fax. +36 1 382 1800  
**India:** Tel. +91 22 493 8541, Fax. +91 22 493 0966  
**Indonesia:** Tel. +62 21 794 0040 ext. 2501, Fax. +62 21 794 0080  
**Ireland:** Tel. +353 1 7640 000, Fax. +353 1 7640 200  
**Israel:** Tel. +972 3 645 0444, Fax. +972 3 649 1007  
**Italy:** Tel. +39 039 203 6838, Fax. +39 039 203 6800  
**Japan:** Tel. +81 3 3740 5130, Fax. +81 3 3740 5057  
**Korea:** Tel. +82 2 709 1412, Fax. +82 2 709 1415  
**Malaysia:** Tel. +60 3 750 5214, Fax. +60 3 757 4880  
**Mexico:** Tel. +9-5 800 234 7381, Fax. +9-5 800 943 0087  
**Middle East:** see Italy

**Netherlands:** Tel. +31 40 27 82785, Fax. +31 40 27 88399  
**New Zealand:** Tel. +64 9 849 4160, Fax. +64 9 849 7811  
**Norway:** Tel. +47 22 74 8000, Fax. +47 22 74 8341  
**Pakistan:** see Singapore  
**Philippines:** Tel. +63 2 816 6380, Fax. +63 2 817 3474  
**Poland:** Tel. +48 22 5710 000, Fax. +48 22 5710 001  
**Portugal:** see Spain  
**Romania:** see Italy  
**Russia:** Tel. +7 095 755 6918, Fax. +7 095 755 6919  
**Singapore:** Tel. +65 350 2538, Fax. +65 251 6500  
**Slovakia:** see Austria  
**Slovenia:** see Italy  
**South Africa:** Tel. +27 11 471 5401, Fax. +27 11 471 5398  
**South America:** Tel. +55 11 821 2333, Fax. +55 11 821 2382  
**Spain:** Tel. +34 93 301 6312, Fax. +34 93 301 4107  
**Sweden:** Tel. +46 8 5985 2000, Fax. +46 8 5985 2745  
**Switzerland:** Tel. +41 1 488 2741, Fax. +41 1 488 3263  
**Taiwan:** Tel. +886 2 2134 2451, Fax. +886 2 2134 2874  
**Thailand:** Tel. +66 2 361 7910, Fax. +66 2 398 3447  
**Turkey:** Tel. +90 216 522 1500, Fax. +90 216 522 1813  
**Ukraine:** Tel. +380 44 264 2776, Fax. +380 44 268 0461  
**United Kingdom:** Tel. +44 208 730 5000, Fax. +44 208 754 8421  
**United States:** Tel. +1 800 234 7381, Fax. +1 800 943 0087  
**Uruguay:** see South America  
**Vietnam:** see Singapore  
**Yugoslavia:** Tel. +381 11 3341 299, Fax. +381 11 3342 553

For all other countries apply to: Philips Semiconductors, Marketing Communications, Building BE-p, P.O. Box 218, 5600 MD EINDHOVEN, The Netherlands, Fax. +31 40 27 24825

Internet: <http://www.semiconductors.philips.com>

© Philips Electronics N.V. 2001

SCS72

All rights are reserved. Reproduction in whole or in part is prohibited without the prior written consent of the copyright owner.

The information presented in this document does not form part of any quotation or contract, is believed to be accurate and reliable and may be changed without notice. No liability will be accepted by the publisher for any consequence of its use. Publication thereof does not convey nor imply any license under patent- or other industrial or intellectual property rights.

Printed in The Netherlands

Date of release: March 2001

Document order number: 9397 750 08077

Let's make things better.



PHILIPS