

**Product:** LEICA GPS Receivers

**Subject:** Replacing the Digital Display (part number: 9525.200.75070)

**Technical Note TN00300A**

**This note cover:** MK10, MX400, MX412 and MX420 Navigators

**Subject:** Replacement of Display

Date: 2000-01-18

Aut.: Lars D. Kristensen

1 of 3 pages including drawing.

---

## **Introduction**

This note describes in a step by step way how to replace the Display (952520075070) in the MK10 series navigators.

## **Tools needed**

- Torx 10 screwdriver

**Illustrations included:** 3508 102 18780 with partlist. (fig 1)

## **Procedure**

1. Put the navigator on a flat smooth surface with the front down.
2. Use the Torx 10 screwdriver to remove the 12 screws (Fig 1 nr. 16) which are placed along the edge. It is in most cases not enough to fully uncsrew them, they have to be removed.
3. It is now possible to separate the front and back part (fig 1 nr 1 and 15). Be careful when they are separated, as there is a coax cable (fig 1 nr. 14) and a connector just below the backpart. The easiest way is to pull in both parts.
4. Disconnect the coax cable from the PCB by pulling the SMB connector at the PCB end. The connector closest to the PCB edge is used for GPS, the other is normally not used, but it is used if a beacon antenna is used separately.
5. Locate the two small white flatcable connectors, they are found next to the battery and close to the edge of the PCB. They connect the keyboard to the PCB. At both ends of the white connector part you will find a locking mechanism. The mechanism is placed at both sides of the flatcable which is coming from the keyboard. Use the tweezer and push firmly towards the edge of the PCB on the small tabs (they look like small ears). The tabs should separate about 1-2mm from the rest of the white connector. The flatcable is now unlocked and can be removed from the connectors.
6. Locate the black connector which is found at the same side of the PCB's as the two white connectors. Disconnect it.

**SPERRY MARINE UK**  
Service Bulletin No. 27

7. Use the TORX 10 screwdriver to unscrew the 3 screws which holds the PCB. The screws are found in the corner of the covered part, next to the black connector and just outside the covered part opposite the two other connectors.
8. Remove the PCB.
9. Take a look at the Beeper ( the flat round dish), it is placed on three rods, with the white side up. Remove the beeper
10. You are now looking at a metallized plastic cover (fig. 1 nr. 5). Use the TORX10 screwdriver to unscrew the 7 screws, and remove the metallized plastic cover.
11. The Display PCB is now loose and can be removed (fig 1 nr. 2). Unpack the new display and place it in the same position as the old one.
12. Place the metallized screen, and remember to put the Backlight connector through the appropriate hole. Fix the screen again by the 7 screws.
13. Place the beeper on the three plastic rods, please observe that the white and brass side must be upwards. Check that the beeper is hold in position by the three rods. The wire for the Backlight must be on the internal side of the nearby rod, if it is on the external side, it will be squeezed when the navigator is assembled.
14. Place the main PCB, be careful not to bent the pin row connector from the display. The pin row is going through the connector. Fix the PCB by the 3 screws. Put the 2 flatcables from the keyboard into the connector, lock the cables by pressing the lock at both sides of the connectors. Connect the backlight connector.
15. Take the backpart, connect the coax cable to the connector which closest to the edge of the PCB. The other connector is normally not used.
16. Place the backpart on the frontpart, be careful when they are pressed together. The connection from the PCB to the backpart is made by two rows of connector pins. The backpart and frontpart must be aligned before they are pressed together, and then the connector will fit into the female part on the backpart. Fix the front and backpart by the screws.
17. The navigator is now again ready and can be tested.

This is the end of the Technical note.

**SPERRY MARINE UK**  
 Service Bulletin No. 27

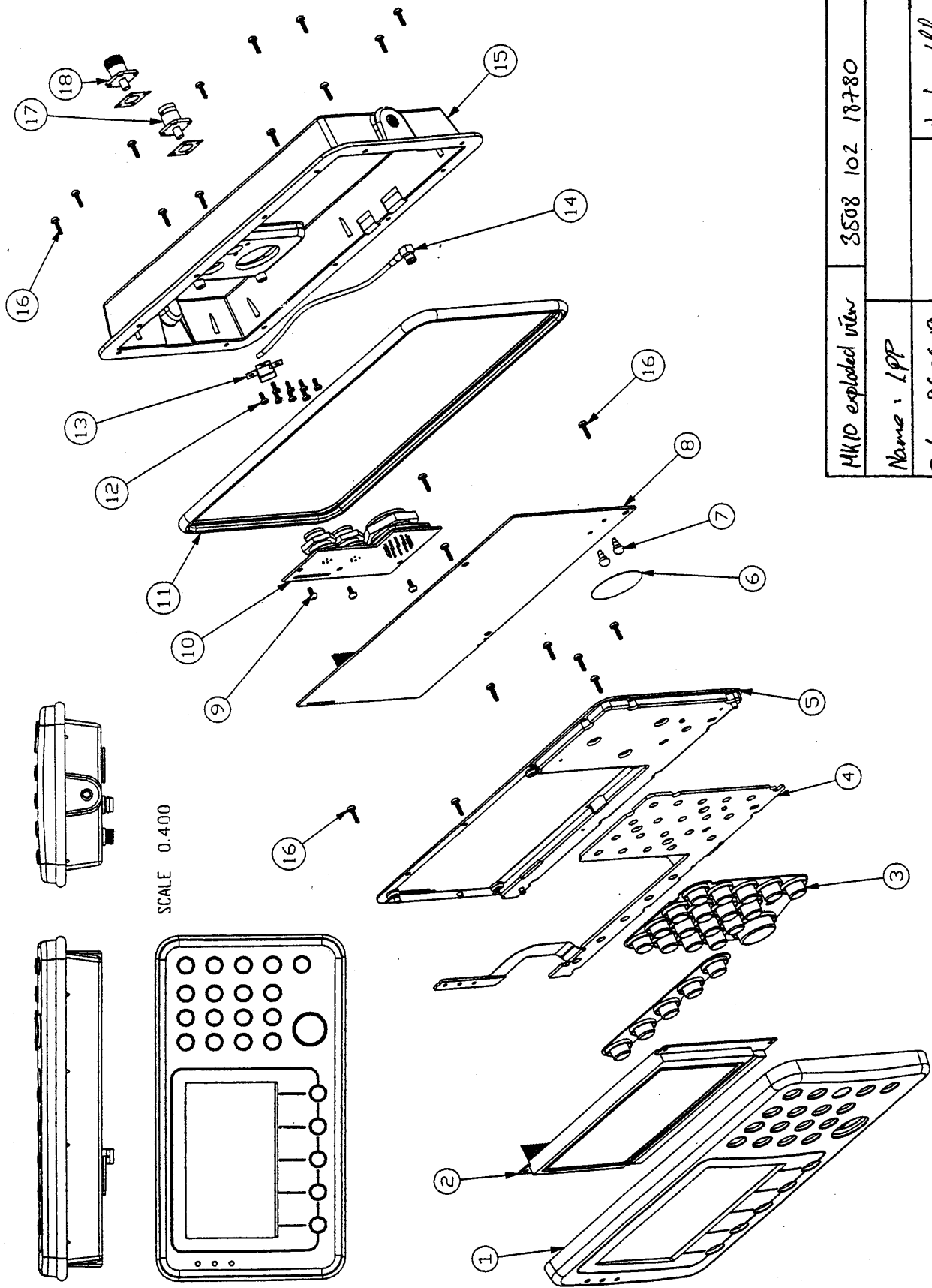

MK10 exploded view	3508 102 18780	Arnb. 1PP
Name: LPP		
Date: 96.06.19		