

PCG-GRZ530

SERVICE MANUAL

Ver 1-2002K

Revision History

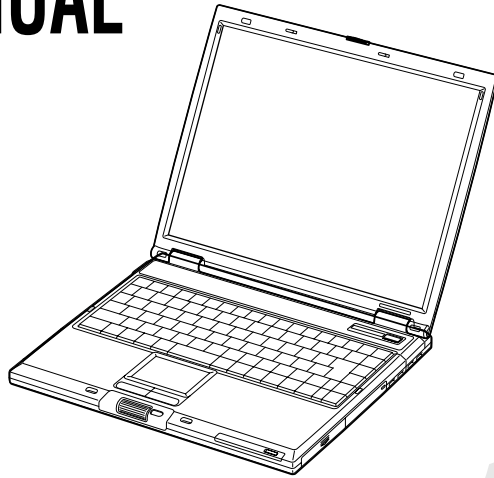

For American Area

US Model

Canadian Model

Lineup : PCG-GRZ530

MEMORY STICK™

 i S400



Confidential

- Design and specifications are subject to change without notice.

NOTEBOOK COMPUTER

SONY®

Information in this document is subject to change without notice.

Sony, VAIO and CLIE are trademarks or registered trademarks of Sony. Microsoft, Windows, Windows Media, Outlook, Bookshelf and other Microsoft products are trademarks or registered trademarks of Microsoft Corporation in the United States and other countries. The word Bluetooth and the Bluetooth logo are trademarks of Bluetooth SIG, Inc. AMD, the AMD logo, other AMD product names and combinations thereof are trademarks of Advanced Micro Devices, Inc. Intel Inside logo, Pentium and Celeron are trademarks or registered trademarks of Intel Corporation. Transmeta, the Transmeta logo, Crusoe Processor, the Crusoe logo and combinations thereof are trademarks of Transmeta Corporation in the USA and other countries. Graffiti, HotSync, PalmModem, and Palm OS are resistered trademarks, and the Hotsync logo and Palm are trademarks of Palm, Inc. or its subsidiaries. (M) and Motrola are trademarks of Motrora, Inc. Other Motrola products and services with (R) mark like Dragomball are the trademarks of Motrola, Inc.

All other names of systems, products and services in this manual are trademarks or registered trademarks of their respective owners. In this manual, the (TM) or (R) mark are not specified.

Caution Markings for Lithium/Ion Battery - The following or similar texts shall be provided on battery pack of equipment or in both the operating and the service instructions.

CAUTION: Danger of explosion if battery is incorrectly replaced. Replace only with the same or equivalent type recommended by the manufacturer. Discard used batteries according to the manufacturer’s instructions.

CAUTION: The battery pack used in this device may present a fire or chemical burn hazard if mistreated. Do not disassemble, heat above 100°C (212°F) or incinerate.

Dispose of used battery promptly.
Keep away from children.

CAUTION: Changing the back up battery.

- Overcharging, short circuiting, reverse charging, multilation or incineration of the cells must be avoided to prevent one or more of the following occurrences; release of toxic materials, release of hydrogen and/or oxygen gas, rise in surface temperature.
- If a cell has leaked or vented, it should be replaced immediately while avoiding to touch it without any protection.

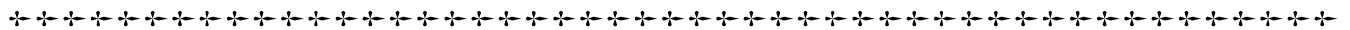

Service and Inspection Precautions

1. Obey precautionary markings and instructions

Labels and stamps on the cabinet, chassis, and components identify areas requiring special precautions. Be sure to observe these precautions, as well as all precautions listed in the operating manual and other associated documents.

2. Use designated parts only

The set’s components possess important safety characteristics, such as noncombustibility and the ability to tolerate large voltages. Be sure that replacement parts possess the same safety characteristics as the originals. Also remember that the Δ mark, which appears in circuit diagrams and parts lists, denotes components that have particularly important safety functions; be extra sure to use only the designated components.

3. Always follow the original design when mounting parts and routing wires

The original layout includes various safety features, such as inclusion of insulating materials (tubes and tape) and the mounting of parts above the printer board. In addition, internal wiring has been routed and clamped so as to keep it away from hot or high-voltage parts. When mounting parts or routing wires, therefore, be sure to duplicate the original layout.

4. Inspect after completing service

After servicing, inspect to make sure that all screws, components, and wiring have been returned to their original condition. Also check the area around the repair location to ensure that repair work has caused no damage, and confirm safety.

5. When replacing chip components...

Never reuse components. Also remember that the negative side of tantalum capacitors is easily damaged by heat.

6. When handling flexible print boards...

- The temperature of the soldering-iron tip should be about 270C.
- Do not apply the tip more than three times to the same pattern.
- Handle patterns with care; never apply force.

Caution: Remember that hard disk drives are easily damaged by vibration. Always handle with care.

ATTENTION AU COMPOSANT AYANT RAPPORT À LA SÉCURITÉ!
LES COMPOSANTS IDENTIFÉS PAR UNE MARQUE Δ SUR LES DIAGRAMMES SCHÉMATIQUES ET LA LISTE DES PIÈCES SONT CRITIQUES POUR LA SÉCURITÉ DE FONCTIONNEMENT. NE REMPLACER CES COMPOSANTS QUE PAR DES PIÈSES SONY DONT LES NUMÉROS SONT DONNÉS DANS CE MANUEL OU DANS LES SUPPÉMENTS PUBLIÉS PAR SONY.

TABLE OF CONTENTS

<u>Section</u>	<u>Title</u>	<u>Page</u>
CHAPTER 1. BLOCK DIAGRAM	1-1
		(to 1-2)
CHAPTER 2. FRAME HARNESS DIAGRAM	2-1
		(to 2-2)
CHAPTER 3. EXPLODED VIEWS AND PARTS LIST	3-1
3-1. Main Section	3-2
3-2. LCD Section – Made by HI –	3-5
3-3. Connector Section (CH Type Only)	3-7
		(to 3-8)
CHAPTER 4. OTHERS	4-1
4-1. Replacing the CPU	4-1
1. Removing the CPU	4-1
2. Installing the CPU	4-1
		(to 4-1)

History of the changes is shown as the “Revision History” at the end of this data.

CHAPTER 1. BLOCK DIAGRAM

BLOCK DIAGRAM Rev. 0.60

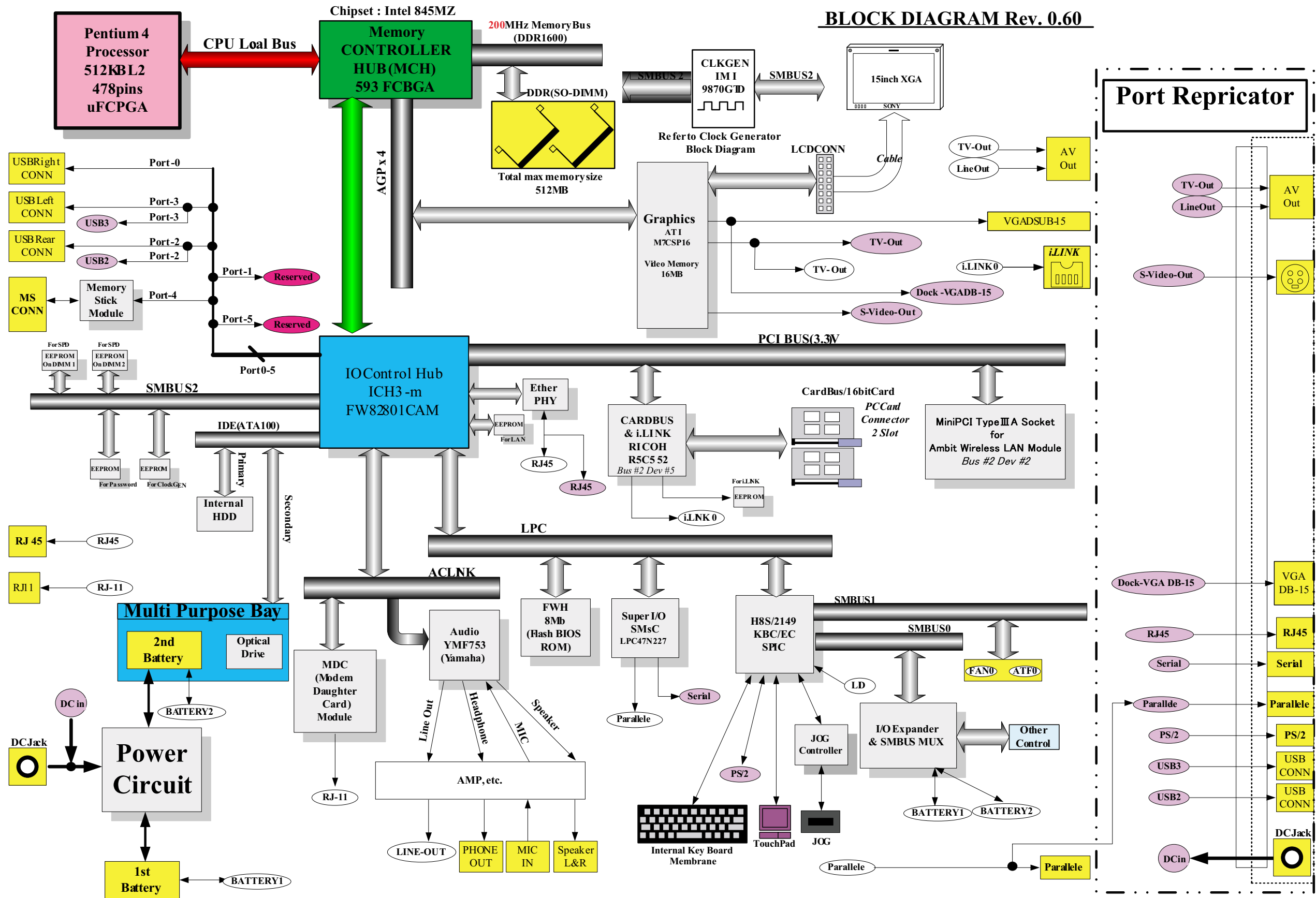

1/1

CHAPTER 2. FRAME HARNESS DIAGRAM

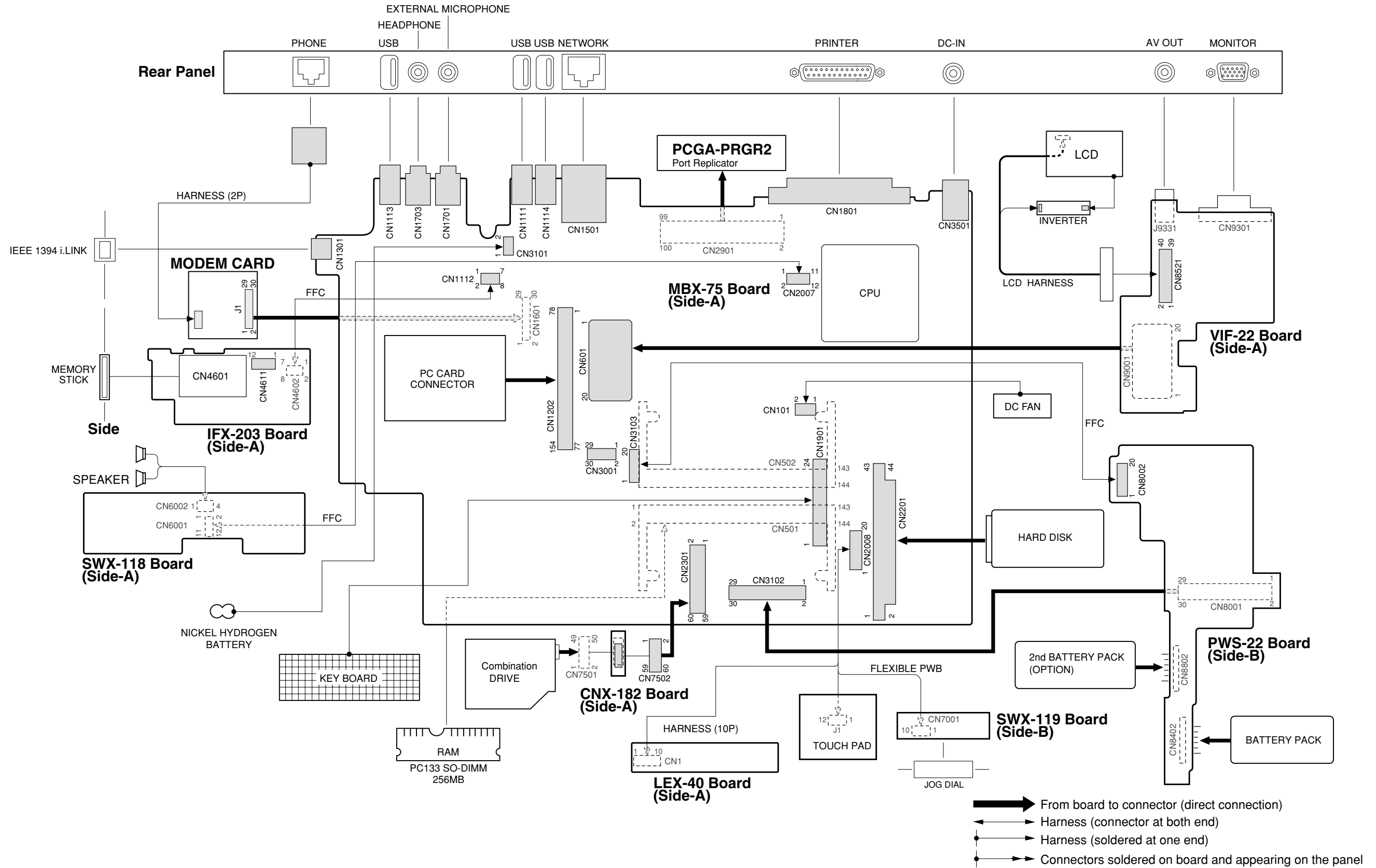

CHAPTER 3.

EXPLODED VIEWS AND PARTS LIST

NOTE:

- Items marked “ * ” are not stocked since they are seldom required for routine service. Some delay should be anticipated when ordering these items.
- The mechanical parts with no reference number in the exploded views are not supplied.
- When two or more parts are shown in parallel, use the part described first as the main part.
- The parts marked “ \$ ” are the High Value Modules.
- The parts marked “ # ” are the parts on which barcode label is attached.
- The indication [CH] is used for identification of part type.
- Regarding the boards of this model, the discrete parts on the boards cannot be replaced. However, Some connectors can be replaced.

The components identified by mark \triangle or dotted line with mark \triangle are critical for safety. Replace only with part number specified.

Les composants identifiés par une marque \triangle sont critiques pour la sécurité. Ne les remplacer que par une pièce portant le numéro spécifié.

【使用上の注意】

- * 印の部品は常備在庫しておりません。
- 図面番号のない部品は供給しません。
- 併記部品の場合、上部記載部品をメイン部品として使用してください。
- 部品名称の前に \$ 印のついた部品は、High Value Module です。
- 商品名称の前に # 印のついた部品は、バーコードラベル貼付部品です。
- [CH]の表記は部品管理上の識別です。
- 本モデルの基板については、基板上の各部品の修理は行うことができません。ただし、一部のコネクタについては、修理可能です。

\triangle 印の部品、または \triangle 印付きの点線で囲まれた部品は、安全性を維持するために重要な部品です。従って交換時は、必ず指定の部品を使用してください。

3-1. Main Section

Ref.No.	Part No.	Description	Ref.No.	Part No.	Description
1	4-667-050-01	ESCUSHION TP	65	X-4625-233-1	ASSY DOOR HDD
2	1-796-166-21	PAD, TOUCH	67	X-4625-236-1	HOUSING BOTTOM ASSY
3	X-4625-237-1	HOUSING (PALM REST) ASSY	68	4-654-379-12	COVER (PORT)
4	4-667-053-01	ESCUSHION JOG	70	4-668-288-01	CUSHION PALM
* 5	4-667-062-01	PLATE GND	71	1-756-038-11	BATTERY NICKEL HYDROGEN
6	9-885-028-59	GT T/P FPC	72	4-642-711-11	[CH]...SHEET (BATTERY), ADHESIVE
7	4-653-795-01	[CH]...BUTTON HOLDER	73		CAPTON TAPE (W19X20) (*1)
* 8	4-667-061-01	BRACKET JOG	74	4-671-241-01	SHEET THERMAL (STH)
9	4-667-037-01	SPEAKER HOLDER L	75	4-668-310-01	GASKET (LAN)
10	A-8067-680-A	\$ GT1 SWX-119 BD ASSY(S)	76	4-666-521-01	LENS COVER (B)
12	8-458-828-72	\$ # RW DRIVE CRX810E-VN	77	4-668-305-01	SHEET HDD
13	A-8067-678-A	\$ GT1 CNX-182 BD ASSY(S)	78	4-668-313-01	ICON SHEET
14	4-667-033-01	CASE BAY	79	4-654-837-01	SHEET BAY BOARD
15	A-8067-766-A	\$ # GT+ MBX-75 BD ASSY(S)	81	4-654-380-31	[CH]...CAP BAY
16	4-668-304-01	SHEET DRIVE	83	X-4625-306-1	PLATE HEATSINK ASSY
17	1-815-594-41	CONNECTOR PC CARD (EJECT RIGHT)	84	4-668-300-01	SHEET ATI
18	4-655-960-11	[CH]...SHEET PC CARD	87	X-4625-163-1	BEZEL CMB (C) ASSY
* 19	4-667-068-01	BRACKET PALMREST R	89	4-668-306-01	SHEET PORT
20	1-761-606-11	# CARD, MODEM	90	4-668-307-01	SHEET DIMM
* 21	4-667-067-01	BRACKET PALMREST L	91	4-668-308-01	SHEET MINI PCI
22	6-600-116-01	IC M470L3224DT0-CB0 (DDR200 SO-DIMM 256MB)	92	4-668-312-01	SHEET DIMM SIDE
22	6-600-167-01	IC MT8VDDT3264HDG-265B3 (DDR200 SO-DIMM 256MB)	93	4-668-297-01	INSULATOR MB SHIELDING
23	X-4625-305-1	BRACKET KEYBOARD ASSY	94	4-668-295-01	FAN INLET SPONGE1
24	X-4625-501-1	BLACKET IO ASSY	95	4-668-296-01	FAN INLET SPONGE2
25	6-703-633-01	IC RK80532PC056512SL6GS (P4 2.4GHz)	96	4-669-868-01	FAN INLET SPONGE 3
26	4-654-119-01	[CH]...PLATE DC	98	4-671-612-01	GT+ SHEET HEATSINK2
27	A-8067-682-A	\$ GT1 VIF-22 BD ASSY(S)	100	4-671-609-01	GT+ MOS PAD R
28	X-4625-238-1	ASSY SHIELDING PALMREST	101	4-671-610-01	GT+ MOS PAD L
29	A-8112-576-A	\$ STH HEAT SINK ASSY (*2)	104	4-671-208-01	SHEET SPEAKER R
30	4-671-611-01	GT+ SHEET HEATSINK1	105	4-671-203-01	SHEET SHIELDING PALMREST
31	4-670-396-01	SHEET COPPER (PLATE HEATSINK)	106	4-671-204-01	SHEET KB1
32	4-653-761-01	[CH]...CAP ETHERNET	107	4-671-205-01	SHEET KB2
33	4-667-060-01	BRACKET ILINK	108	4-671-206-01	SHEET HOUSING BOTTOM
34	1-824-997-11	FFC (20P)	109	4-671-207-01	BOARD DOCKING
36	A-8067-767-A	\$ GT+ PWS-22 BD ASSY(S)	110	4-671-608-01	GT+ GASKET HEATSINK
37	X-4625-234-1	ASSY (DOOR MDC)	B1	4-654-387-01	SCREW (MBX)
38	4-667-066-01	BRACKET (PHONE)	B2	4-641-726-41	SCREW (M2), SPECIAL HEAD
39	X-4625-239-1	ASSY LATCH DETECTOR	B3	4-669-867-01	SCREW (M2X4), SPECIAL HEAD
40	9-885-028-60	HARNESS, 2PIN	B4	4-639-112-01	SCREW M2X4
41	A-8067-679-A	\$ GT1 LEX-40 BD ASSY(S)	B6	4-635-301-01	SCREW M3X4
42	4-668-294-01	FOOT FRONT	B7	4-635-966-01	SCREW (HEX)
45	4-667-052-01	DOOR BATTERY	B8	4-656-703-01	SCREW M2
46	4-668-299-01	DOOR BATTERY SPRING	B10	4-654-386-01	SPACER (PWS)
47	X-4625-307-1	DOOR IO ASSY	B11	4-654-385-01	SPACER (VIF)
49	X-4625-235-1	ASSY DOOR DIMM	B12	4-661-107-01	STAND OFF M2X5
50	X-4625-232-1	ASSY HOOD KEYBOARD	B13	4-644-899-01	SCREW (M2), 0 NUMBER P3 KIND
51	4-654-606-01	SHEET (MS)	B14	4-654-811-01	SCREW M3
52	A-8067-442-A	\$ COMPLETE PWB IFX-203 (2240)	B15	7-622-205-05	NUT (M2 TYPE2), HEXAGON
53	1-529-878-31	SPEAKER (2.8CM)	B17	4-641-726-81	SCREW (M2), SPECIAL HEAD
54	4-667-038-01	SPEAKER HOLDER R			
55	1-823-099-11	CABLE, FLEXIBLE FLAT			
56	A-8067-684-A	\$ GT1 SWX-118 BD ASSY(S)			
57	1-827-082-11	FFC 12PIN (120)			
58	4-668-301-01	SHEET PWS1			
59	4-668-302-01	SHEET PWS2			
60	1-477-580-21	# KEY BOARD UNIT (US)			
61	4-667-074-01	BASE DISPLAY			
62	A-8112-366-A	\$ # HDD (MK3018GAS-30GB) (S)			
63	4-653-801-11	[CH]...SHEET HDD			
64	4-653-799-11	[CH]...BRACKET HDD			

*1 Use the CAPTON TAPE.

*2 When removing "STH HEAT SINK ASSY", a JIG is required.

For more information, refer to "Dessemply & Assembly Guide".

Confidential

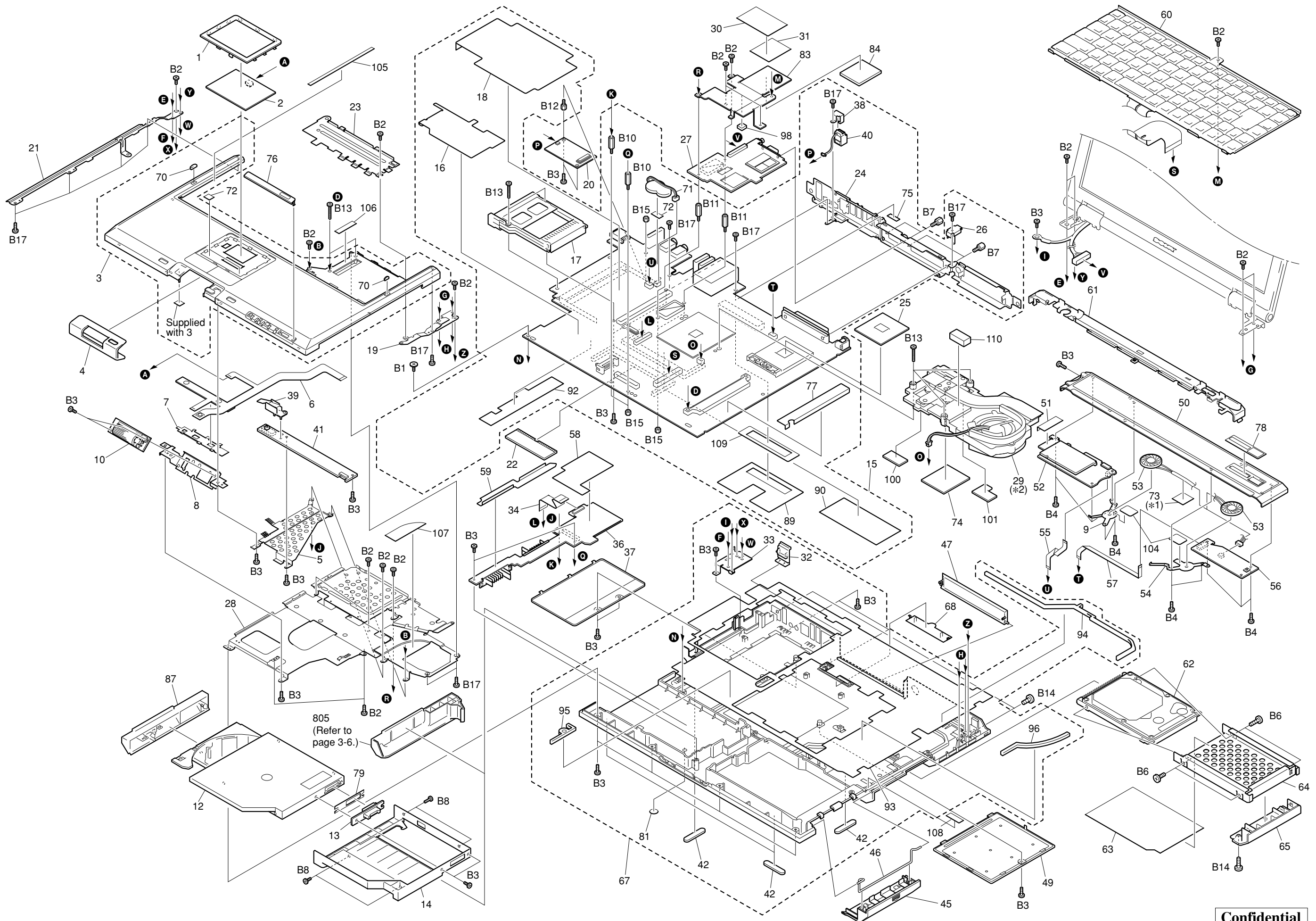

3-2. LCD Section – Made by HI-

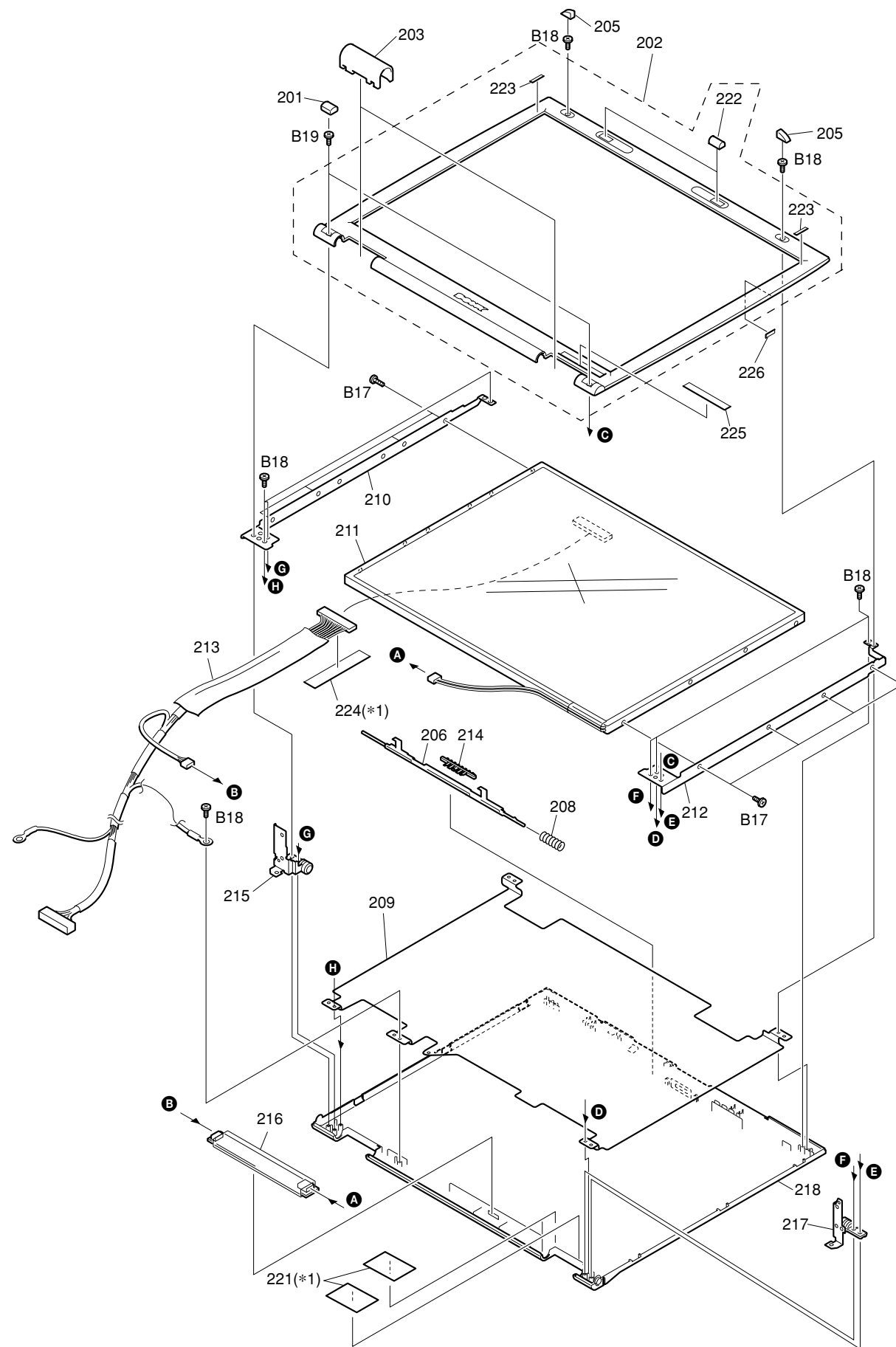

Ref.No.	Part No.	Description
201	4-666-090-01	COVER SCREW LOWER
202	X-4625-183-3	HOUSING (BZEL15) ASSY
203	4-667-073-01	COVER HINGE
205	4-666-091-01	COVER SCREW UPPER
206	4-666-340-01	LATCH HONTAI
208	4-639-623-11	SPRING (LATCH), COIL
209	4-666-253-01	SHIELD DISPLAY
* 210	4-666-430-03	BRACKET LCD 15 (L)
211	A-8067-507-A \$ #	ASSY LCD 15HI AP2(S)
* 212	4-666-429-03	BRACKET LCD 15 (R)
213	1-961-757-13	LCD HARNESS
214	4-666-339-02	LATCH BUTTON
* 215	X-4625-151-1	HINGE LEFT
216	1-476-316-31	INVERTER UNIT
* 217	X-4625-152-1	HINGE RIGHT
218	X-4625-182-2	HOUSING (DISPLAY15) ASSY
221		FILAMENT TAPE (W19X20) (*1)
222	4-666-088-01	CUSHION LATCH
223	4-666-955-01	CUSHION BEZEL
224		FILAMENT TAPE (W19X50) (*1)
225	4-669-751-01	LABEL (ID) (U)
226	4-670-672-01	SPACER BEZEL
B17	4-641-726-81	SCREW (M2), SPECIAL HEAD
B18	4-641-726-61	SCREW (M2), SPECIAL HEAD
B19	4-664-453-21	SCREW(M2X4), SPECIAL HEAD

*1 Use the FILAMENT TAPE.

NOTE :

Set the DIP switch on the MBX-75 board (Main board) to match with the LCD that is used in this computer.



The upper position where ON indication is shown is the ON position. The lower position is the OFF position.

No.	1	2	3	4	5	6	7	8
ON/OFF	0	1	1	1	1	1	1	1

0 : ON 1: OFF

Ref.No.	Part No.	Description
		ACCESSORIES *****
△ 801	1-477-206-32 \$	ADAPTOR, AC
802	A-8112-427-A \$ #	BP2NX SNT(U)ASSY(S)
△ 803	1-757-562-21	CORD, POWER
804	4-653-768-02	WEIGHT SAVER (Refer to page 3-3.)
	4-669-754-01	QUICK (START)
	4-669-779-01	SPECIFICATIONS SHEET

801
AC Adaptor (1)

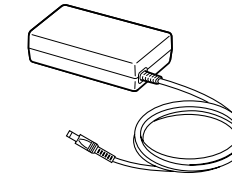

803
Power Cord (1)

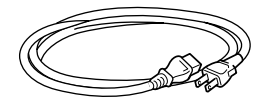

802
Battery Pack (1)



804
Weight Saver (1)

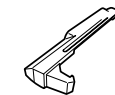

The components identified by mark △ or dotted line with mark △ are critical for safety. Replace only with part number specified.

Les composants identifiés par une marque △ sont critiques pour la sécurité. Ne les remplacer que par une pièce portant le numéro spécifié.

3-3. Connector Section (CH Type only)

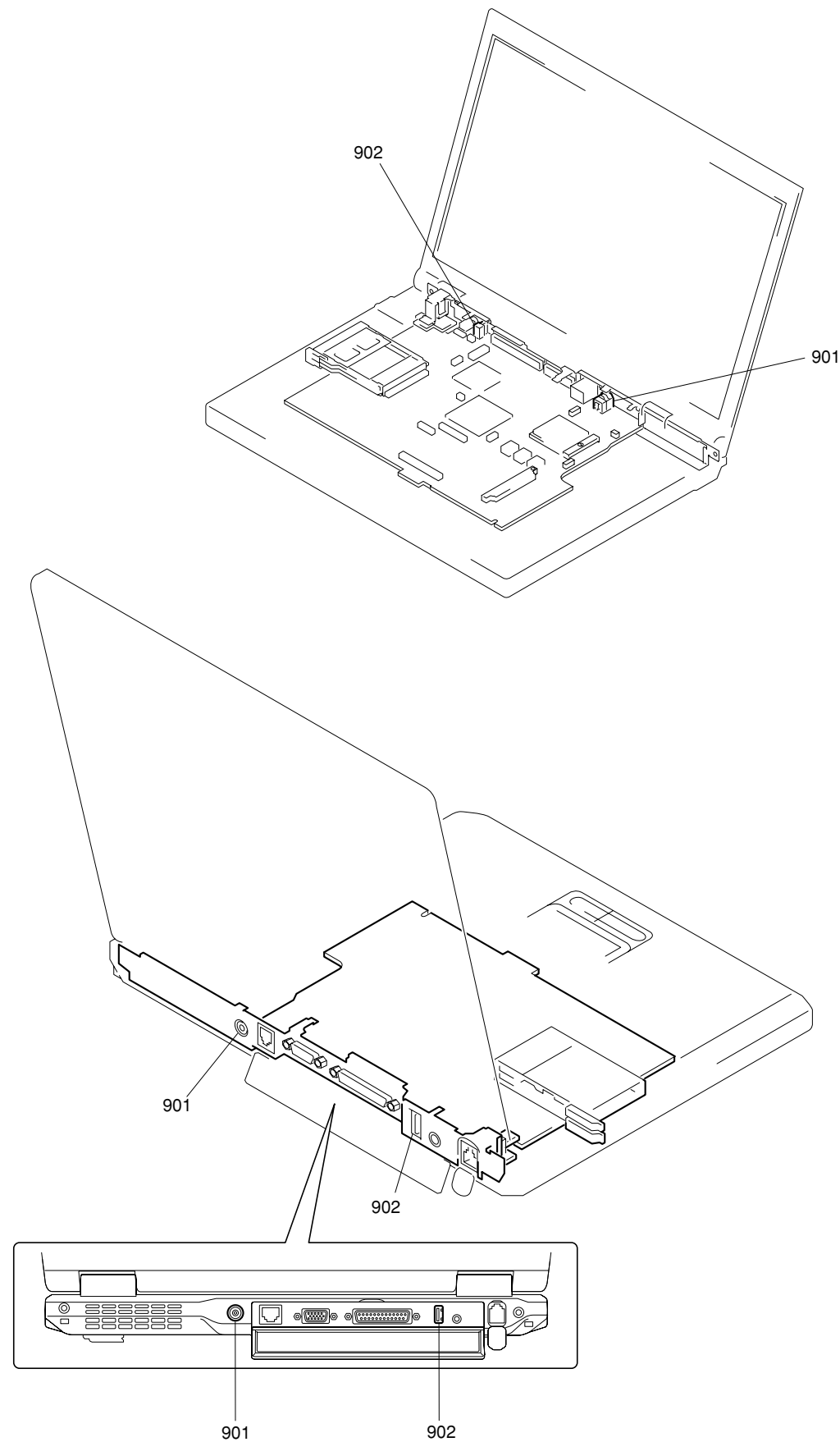

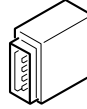
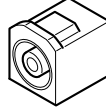
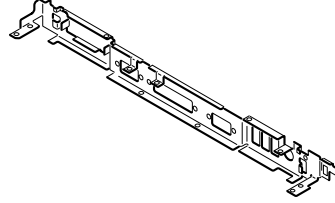
Ref.No.	Fig.	Part No.	Description
901		1-817-023-11	[CH]...CONNECTOR, USB USB connector
902		1-779-745-21	[CH]...JACK, DC DC IN connector
903		X-4625-501-1	[CH]...BRACKET IO ASSY I/O Bracket

* Among the parts that are used on the boards of this model, only the connectors that are show in the list can be replaced.
(The parts other that the specified connectors cannot be replaced.)

4-1. Replacing the CPU

1. Removing the CPU

- ① Insert a flat-blade screwdriver into the notch as shown in the illustration and rotate it so that the protrusion comes to the lock release position.
- ② Pull the CPU gently upward to lift it out of the CPU socket.

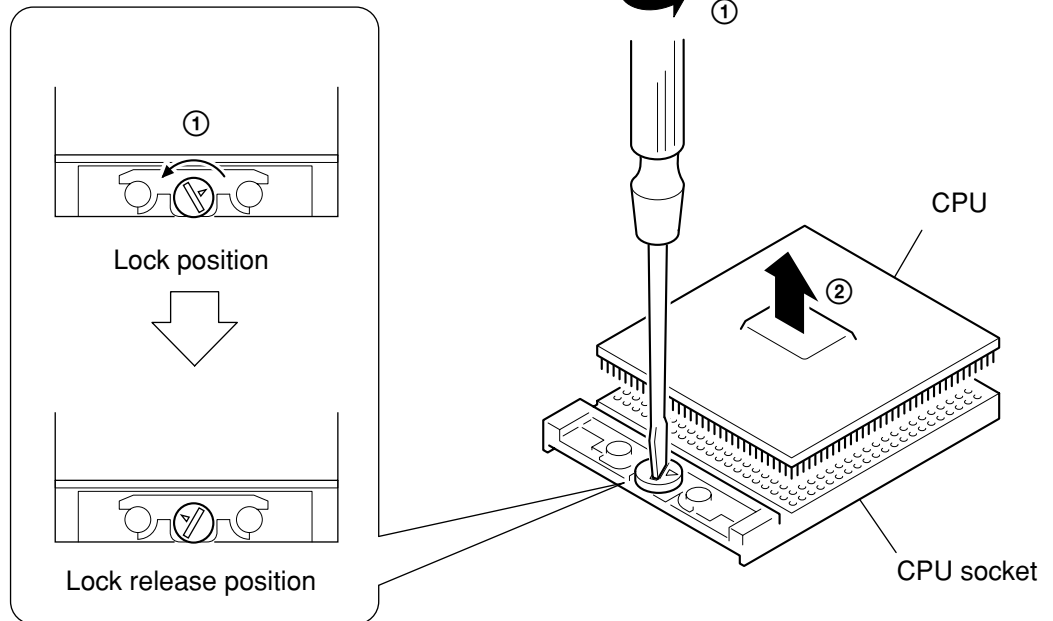

2. Installing the CPU

- ① Align the triangle reference mark of the CPU with that of the CPU socket and insert all the pins of the CPU to the corresponding holes of the CPU socket.
- ② Insert a flat-blade screwdriver into the notch as shown in the illustration and rotate it so that the protrusion comes to the lock position.

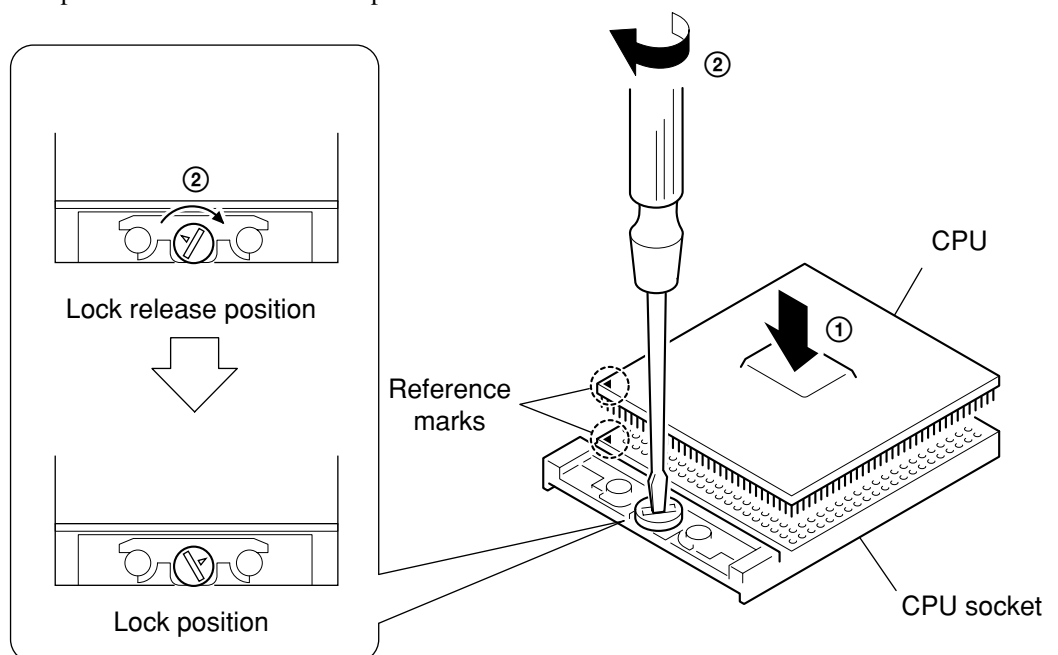

NOTE:

Rotate a flat-blade screwdriver to the lock position securely. If not, the operation of the CPU may become unstable.

List of PCG-GRZ Series (As of November, 2002)

Model Name	Service Manual Part No.
PCG-GRZ530	9-876-035-01

This manual and the constituent data may not be replicated, copied nor reprinted in whole or in part without prior written authorization of Sony Corporation.

Revision History

Suffix	Ver.	Date	Contents	QM No.
-01	Ver. 1	2002.11.14	First Edition	
< Remarks >				