

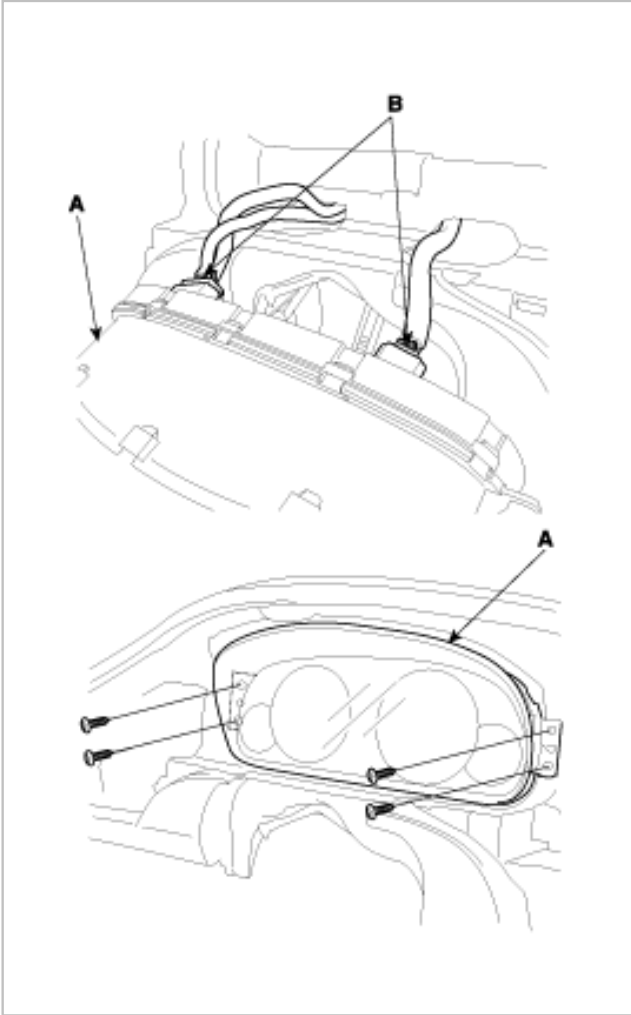

## REMOVAL

1. Disconnect the negative(-) battery terminal.
2. Remove the cluster facia panel.  
(see BD group-crash pad)
3. Remove the cluster(A) from the housing after removing 4 screws and disconnect the wire connectors (B).



4. Installation is the reverse of removal.

## INSPECTION

### SPEEDOMETER

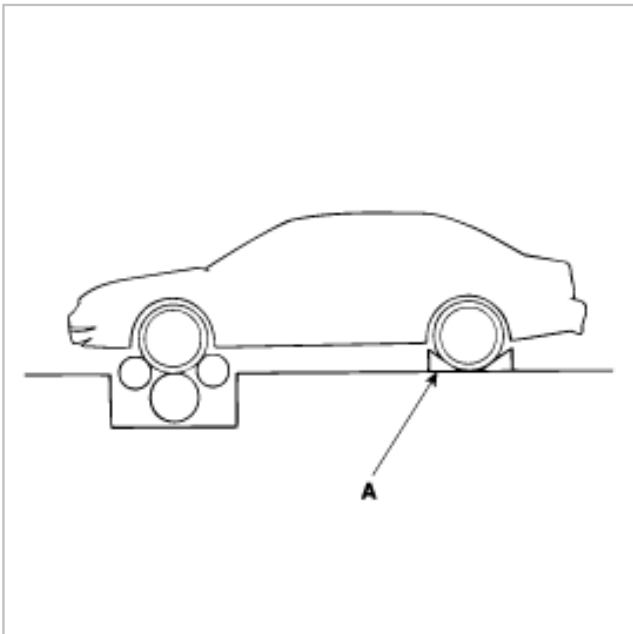

1. Adjust the pressure of the tires to the specified level.
2. Drive the vehicle onto a speedometer tester. Use wheel chocks(A) as appropriate.
3. Check if the speedometer indicator range is within the standard values.

**CAUTION**

Do not operate the clutch suddenly or increase/ decrease speed rapidly while testing.

**NOTE**

Tire wear and tire over or under inflation will increase the indication error.

Velocity (km/h)	20	40	60	80	100
Tolerance (km/h)	±2.4				
Velocity (km/h)	120	140	160	180	200
Tolerance (km/h)					

Velocity (MPH)	10	20	40	60	80	100	120	Remark
Tolerance (MPH)								U.S.A

**VEHICLE SPEED SENSOR**

1. Connect the positive (+) lead from battery to terminal 3 and negative (-) lead to terminal 1.
2. Connect the positive (+) lead from tester to terminal 2 and the negative (-) lead to terminal 1.
3. Rotate the shaft.
4. Check that there is voltage change from approx. 0V to 11V or more between terminals 1 and 2.

- The voltage change should be 4 times for every revolution of the speed sensor shaft.  
If operation is not as specified, replace the sensor.

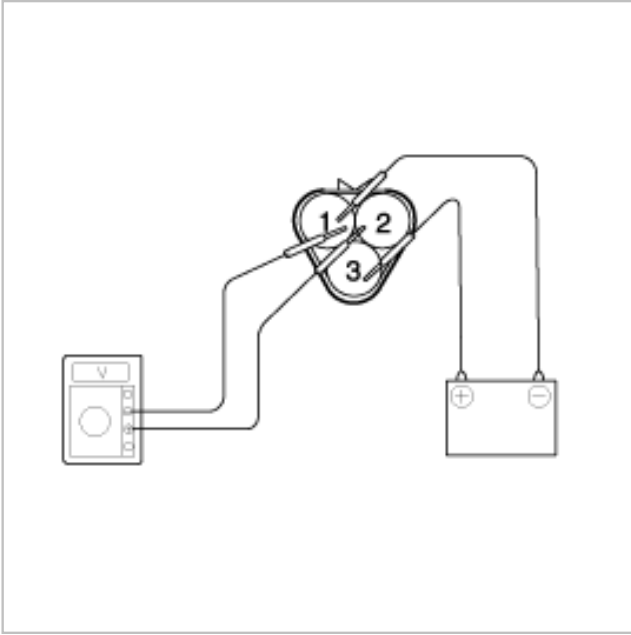

## TACHOMETER

- Connect the scan tool to the diagnostic link connector or install a tachometer.
- With the engine started, compare the readings of the tester with that of the tachometer. Replace the tachometer if the tolerance is exceeded.

### CAUTION

- Reversing the connections of the tachometer will damage the transistor and diodes inside.
- When removing or installing the tachometer, be careful not to drop it or subject it to severe shock.

Revolution (RPM)	1,000	2,000	3,000	4,000	5,000	6,000	7,000	Remark
Tolerance (RPM)	±100	±125	±150	±150	±150	±180	±210	Gasoline

## FUEL GAUGE

- Disconnect the fuel sender connector from the fuel sender.
- Connect a 3.4 watt, 12V test bulb to terminals 1 and 3 on the wire harness side connector.

3. Turn the ignition switch to the ON, and then check that the bulb lights up and the fuel gauge needle moves to full.

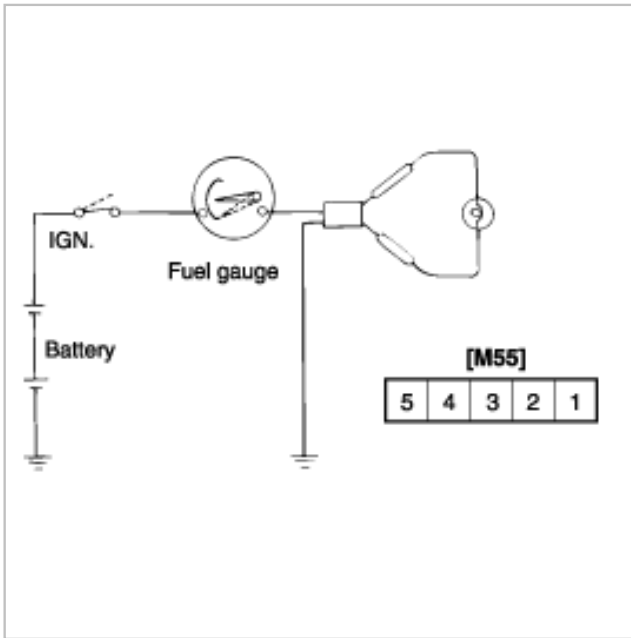

## FUEL SENDER

1. Using an ohmmeter, measure the resistance between terminals 1 and 3 at each float level.

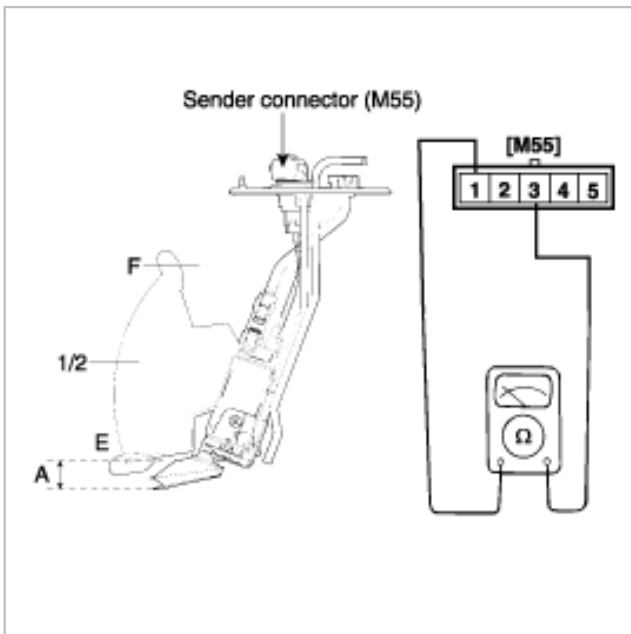

2. Also check that the resistance changes smoothly when the float is moved from "E" to "F".

Position	Height (A) (mm)	Resistance( )
Sender (E)	35.9 ± 2	200.0 ± 2
Gauge (E)	37.9 ± 2	184.0 ± 2
Warning lamp	42.2 ± 2	170.0 ± 2
1/2	90.2 ± 2	66.0 ± 1
Gauge (F)	128.0 ± 2	15.0 ± 1
Sender (F)	133.9 ± 2	8.0 ± 1

3. If the height resistance is unsatisfied, replace the fuel sender as an assembly.

**CAUTION**

After completing this test, wipe the sender dry and reinstall it in the fuel tank.

### ENGINE COOLANT TEMPERATURE GAUGE

1. Disconnect the wiring connector(A) from the engine coolant temperature sender in the engine compartment.
2. Turn the ignition switch ON. Check that the gauge needle indicates cool. Turn the ignition switch OFF.
3. Connect a 12V, 3.4 watt test bulb between the harness side connector and ground.
4. Turn the ignition switch ON.
5. Verify that the test bulb flashes and that the indicator moves to HOT.

If operation is not as specified, replace the engine coolant temperature gauge. Then recheck the system.



### ENGINE COOLANT TEMPERATURE SENDER

1. Using an ohmmeter, measure the resistance between the terminal 2 and ground.

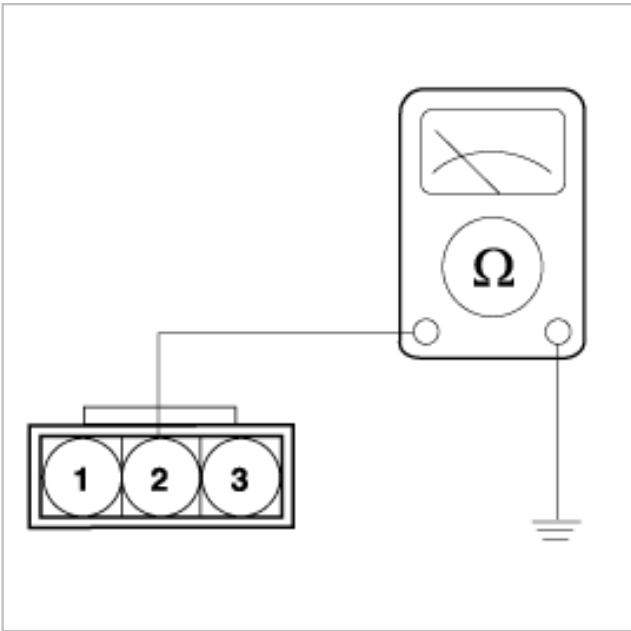

2. If the resistance value is not as shown in the table, replace the temperature sender.

Temperature (°C)	60	85	110	125
Gauge angle (°)	-43±2.4	-7±2.4	-7±2.4	40±2.4
Resistance ( )	128	53.8	25.8	17.1

## OIL PRESSURE SWITCH

1. Check that there is continuity between the oil press switch terminal(A) and ground with the engine off.
2. Check that there is no continuity between the terminal and ground with the engine running.
3. If operation is not as specified, replace the switch.

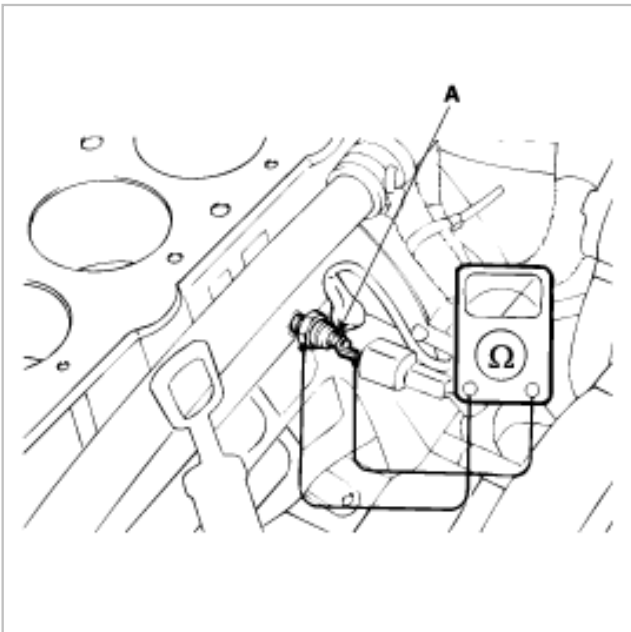

## OIL PRESSURE WARNING LAMP

1. Disconnect the connector (A) from the warning switch and ground the terminal on the wire harness side connector.
2. Turn the ignition switch ON. Check that the warning lamp lights up. If the warning lamp doesn't light, test the bulb or inspect the wire harness.

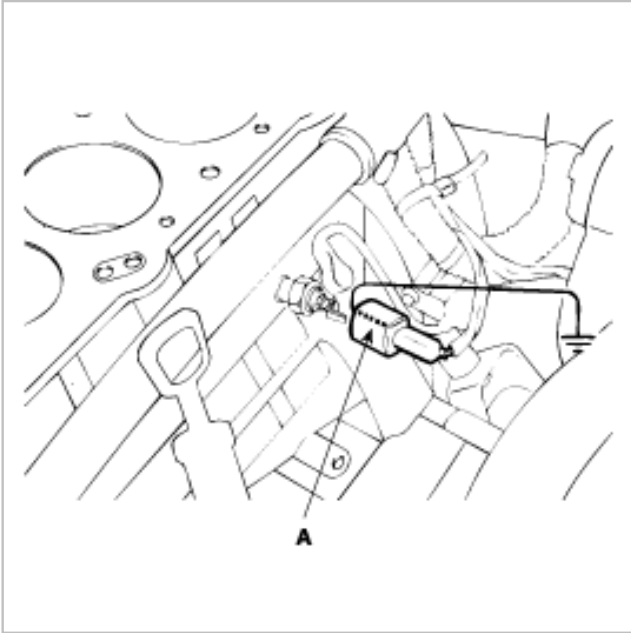

### **BRAKE FLUID LEVEL WARNING SWITCH**

1. Remove the connector(A) from the switch located at the brake fluid reservoir.
2. Verify that continuity exists between switch terminals 1 and 2 while pressing the switch (float) down with a rod.

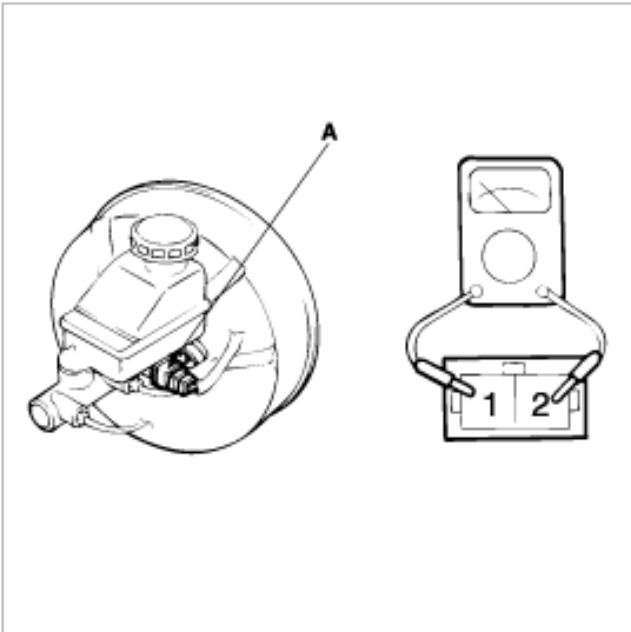

### **BRAKE FLUID LEVEL WARNING LAMP**

1. Start the engine.
2. Release the parking brake.
3. Remove the connector from the brake fluid level warning switch(A).
4. Ground the connector at the harness side.

5. Verify that the warning lamp lights.

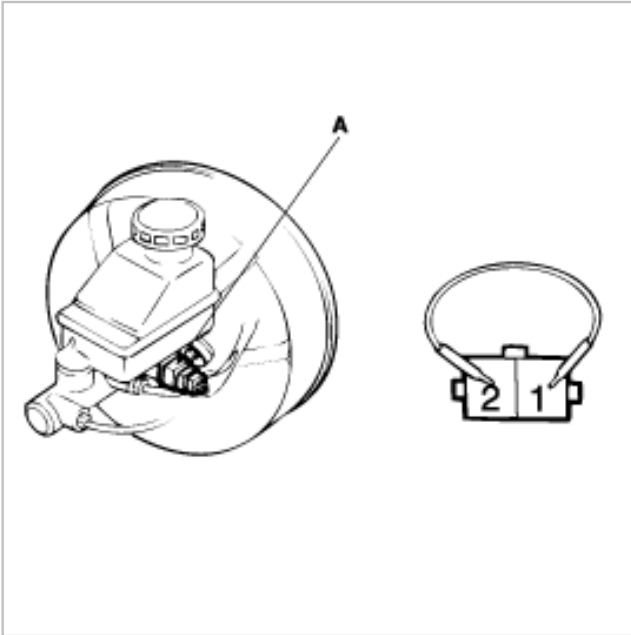

### PARKING BRAKE SWITCH

The parking brake switch(A) is a push type located under the parking brake lever. To adjust, move the switch mount up and down with the parking brake lever released all the way.

1. Check that there is continuity between the terminal and switch body with the switch ON (Lever is pulled).
2. Check that there is no continuity between the terminal and switch body with the switch OFF (Lever is released).

If continuity is not as specified, replace the switch or inspect its ground connection.

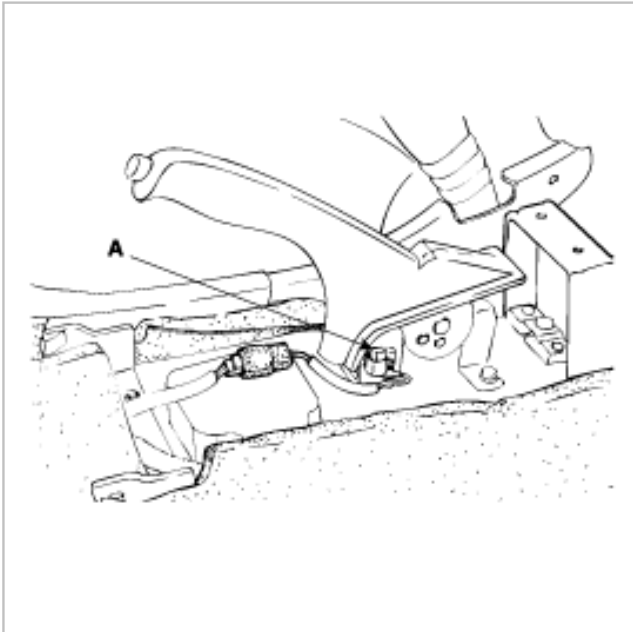

### DOOR SWITCH

Remove the door switch and check for continuity between the terminals.



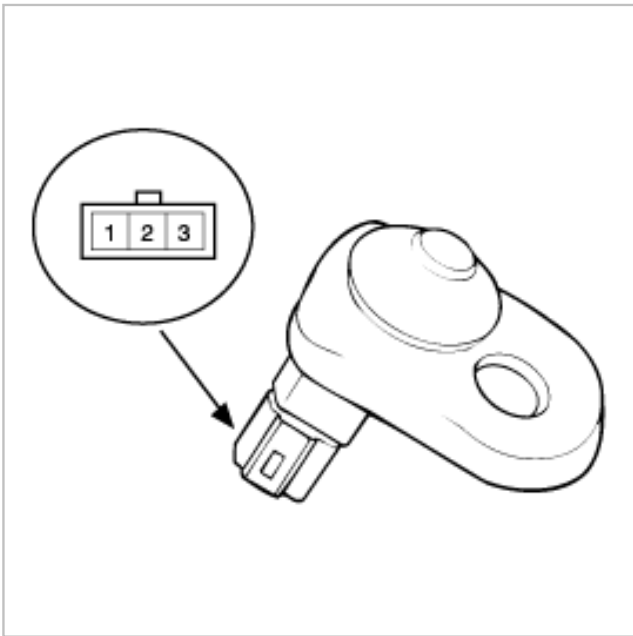

### [ FRONT DOOR SWITCH ]

Terminal	1	2	3 (Ground)
Position			
Free(Door open)	○	○	○
Push(Door close)			

### [ REAR DOOR SWITCH ]

Terminal	2	3 (Ground)
Position		
Free(Door open)	○	○
Push(Door close)		

### SEAT BELT SWITCH

1. Remove the connector from the switch.
2. Check for continuity between terminals.

Seat belt condition	Continuity
Fastened	Non-conductive (∞ )
Not fastened	Conductive ( )

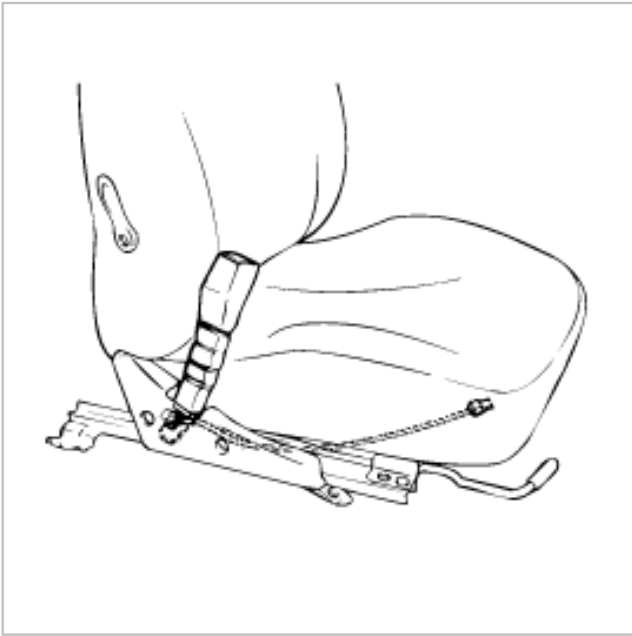

## SEAT BELT WARNING LAMP

With the ignition switch turned ON, verify that the lamp glows.

Seat belt condition	Warning lamp
Fastened	OFF
Not fastened	ON