



## REPLACEMENT

### CAUTION

Frequent inhalation of brake pad dust, regardless of material composition, could be hazardous to your health.

- Avoid breathing dust particles.
- Never use an air hose or brush to clean brake assemblies.

1. Loosen the front wheel nuts slightly. Raise the front of the vehicle, and make sure it is securely supported. Remove the front wheels.
2. Remove the brake hose mounting bolts (A) from the knuckle.

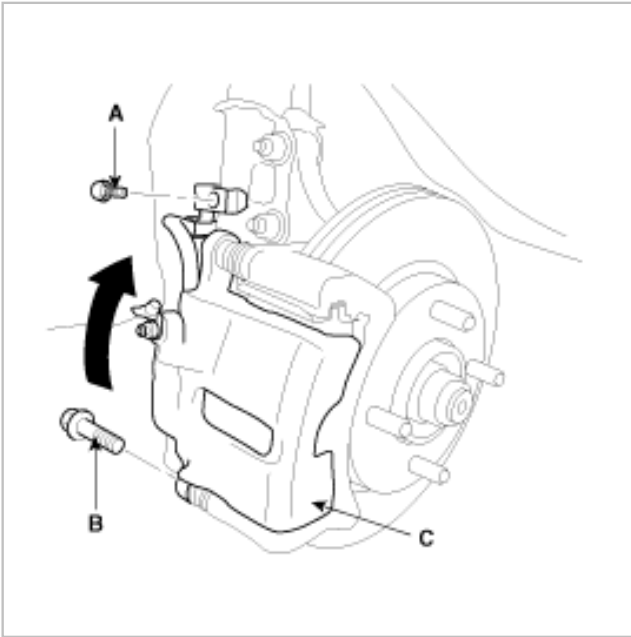

3. Remove guide rod (B) and the caliper (C) up out of the way. Check the hoses and pin boots for damage and deterioration.
4. Remove the pad shims (A), pad retainers (B) and pads (C).

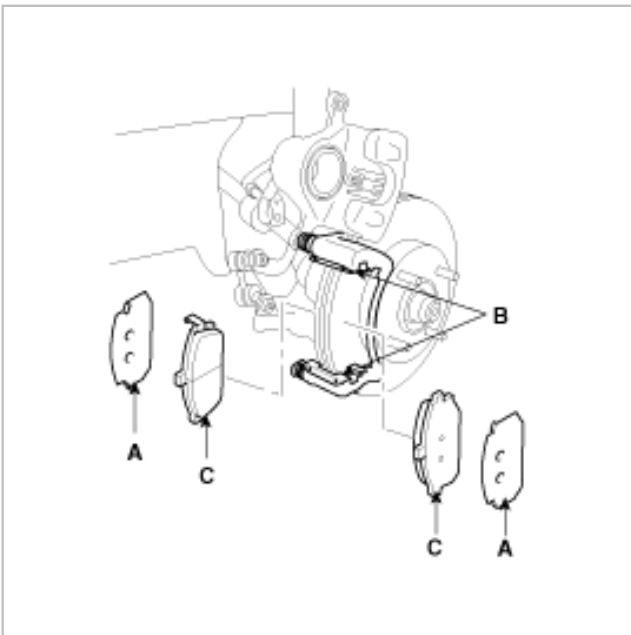

- Using vernier calipers, measure the thickness of each brake pad lining. The measurement does not include pad backing plate (A) thickness.

**Brake pad thickness:**

11mm (0.43 in.)

2mm (0.079 in.)

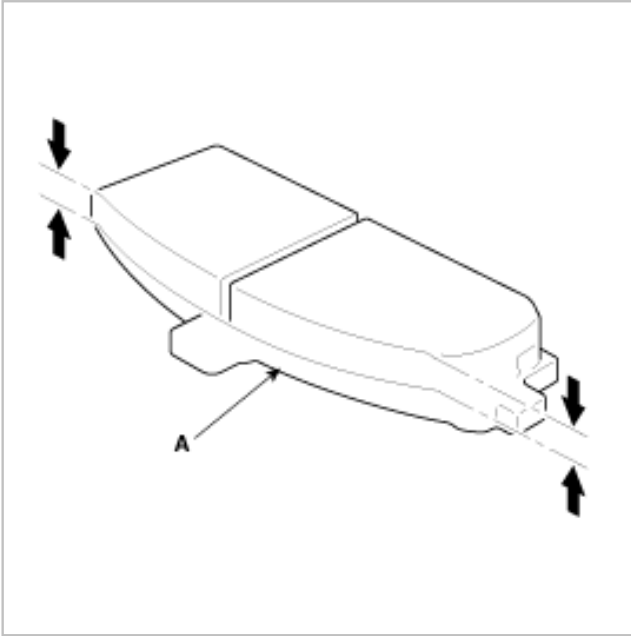

- If the brake pad thickness is less than service limit, replace the front pads as a set.
- Clean the caliper thoroughly; remove any rust, and check for grooves and cracks.
- Check the brake disc for damage and cracks.
- Install the pad retainers (A).

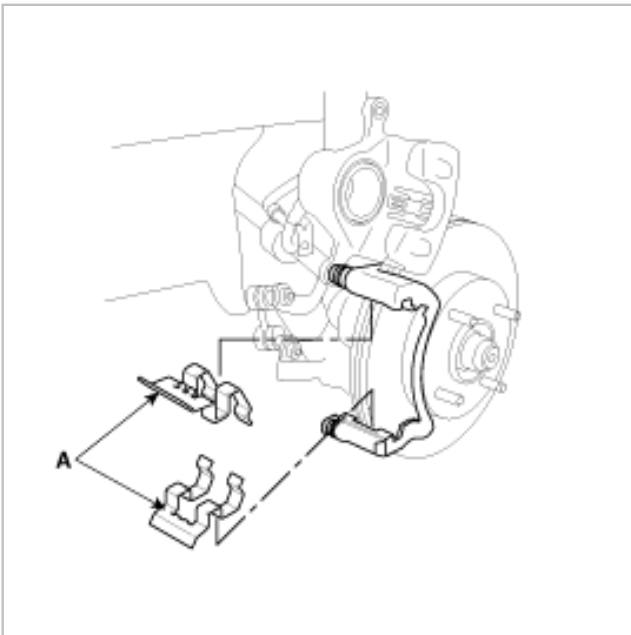

10. Check the foreign material at the pad shims (A) and the back of the pads (B).

Contaminated brake discs or pads reduce stopping ability. Keep grease off the discs and pads.

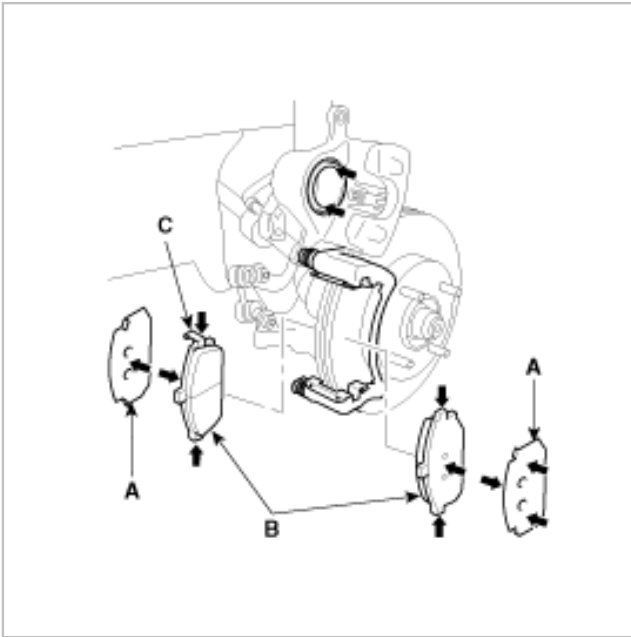

11. Install the brake pads (B) and pad shims (A) correctly. Install the pad with the wear indicator (C) on the inside. If you are reusing the pads, always reinstall the brake pads in their original positions to prevent a momentary loss of braking efficiency.

12. Push in the piston (A) so that the caliper will fit over the pads. Make sure that the piston boot is in position to prevent damaging it when pivoting the caliper down.

13. Pivot the caliper down into position. Being careful not to damage the pin boot, install the guide rod bolt (B) and torque it to proper specification.

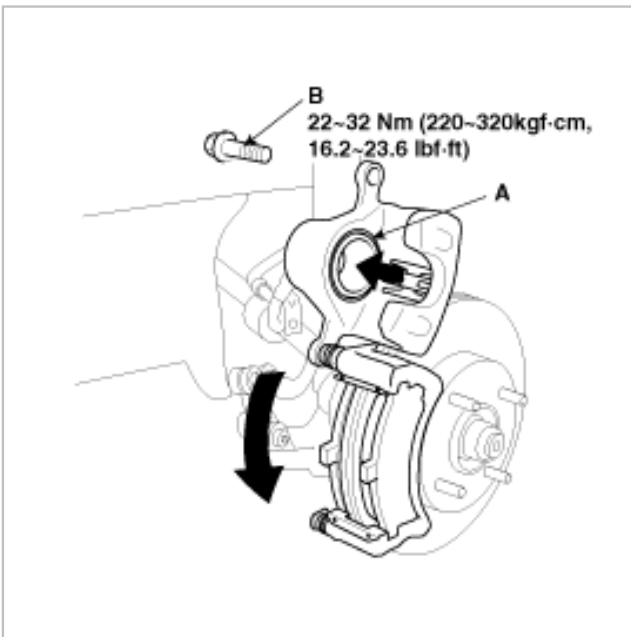

## NOTE

Insert the piston in the cylinder using the special tool (09581-11000).

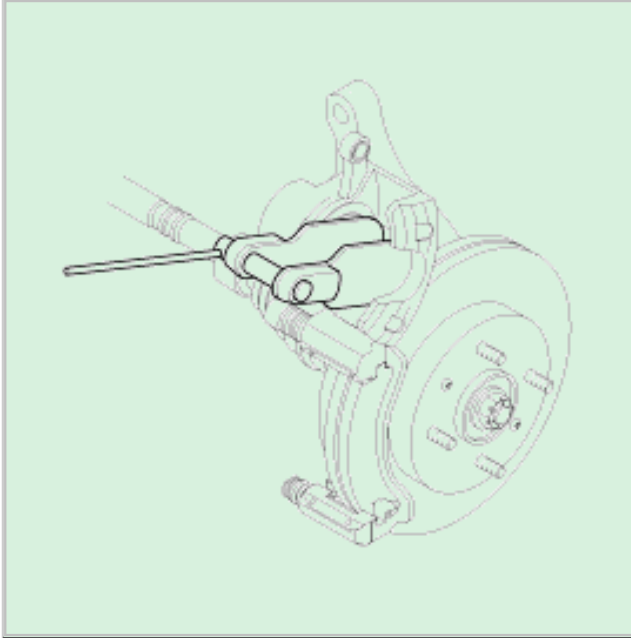

14. Install the brake hose on to the knuckle.
15. Depress the brake pedal several times to make sure the brakes work, then test-drive.

## NOTE

Engagement of the brake may require a greater pedal stroke immediately after the brake pads have been replaced as a set. Several applications of the brake will restore the normal pedal stroke.

16. After installation, check for leaks at hose and line joints or connections, and retighten if necessary.

## INSPECTION

### Runout

1. Loosen the front wheel nuts slightly, then raise the vehicle and make sure it is securely supported.  
Remove the front wheels.
2. Remove the brake pads (see page BR-27).
3. Inspect the disc surface for damage and cracks.  
Clean the disc thoroughly and remove all rust.
4. Use wheel nuts and suitable flat washers (A) to hold the disc securely against the hub, then mount a dial indicator as shown, and measure the runout at 10 mm (0.4 in.) from the outer edge of the disc.

#### **Brake disc runout:**

0.10 mm (0.004 in.)

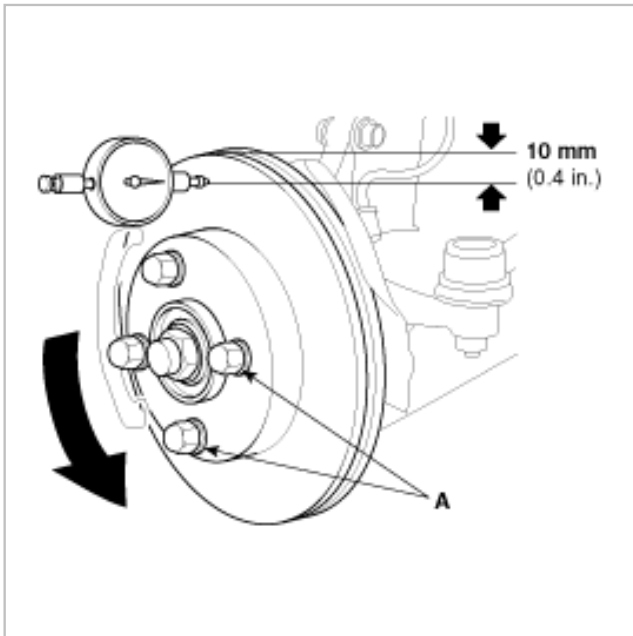

5. If the disc is beyond the service limit, refinish the brake disc with an on-car brake lathe.

22.4 mm (0.882 in.)

#### NOTE

- If the brake disc is beyond the service limit for refinishing, replace it (see page BR-27).
- A new disc should be refinished if its runout is greater than 0.10 mm (0.004 in.).

### Thickness and parallelism

1. Loosen the front wheel nuts slightly, then raise the vehicle and make sure it is securely supported.  
Remove the front wheels.
2. Remove the brake pads (see page BR-27)
3. Using measure disc thickness at eight points, approximately 45° apart and 10 mm (0.4 in.) in from the outer edge of the disc. Replace the brake disc if the smallest measurement is less than the max. refinishing limit.

#### Brake disc thickness:

24 mm (0.945 in.)

22.4 mm (0.882 in.)

Max. 0.015 mm (0.0006 in.)

## NOTE

This is the maximum allowable difference between the thickness measurements.

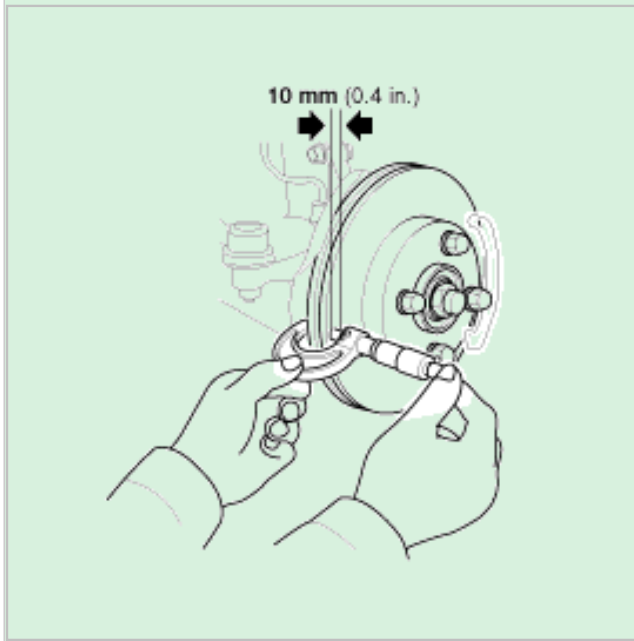

4. If the disc is beyond the service limit for parallelism, refinish the brake disc with an on-car brake lathe.

## NOTE

If the brake disc is beyond the service limit for refinishing, replace it (see DS group-front axle).

## REPLACEMENT

### CAUTION

Frequent inhalation of brake pad dust, regardless of material composition, could be hazardous to your health.

- Avoid breathing dust particles.
- Never use on air hose or brush to clean brake assemblies.

1. Loosen the front wheel nuts slightly. Raise the front of the vehicle, and make sure it is securely supported. Remove the front wheels.
2. Remove the brake hose mounting bolts (A) from the knuckle.

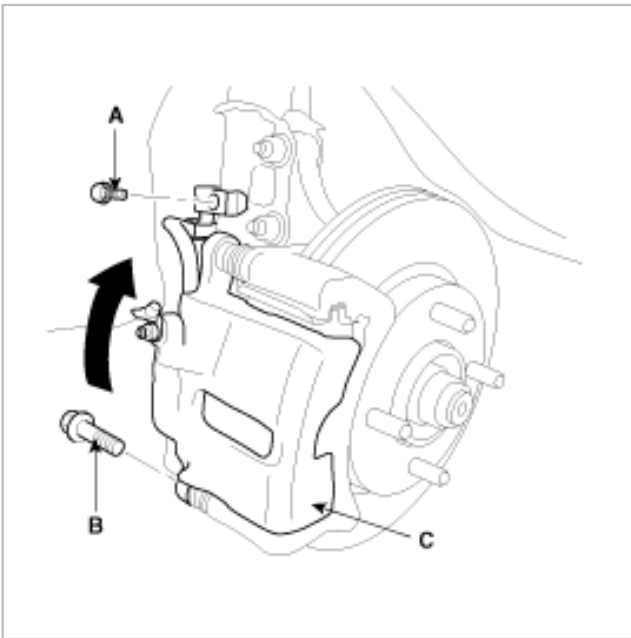

3. Remove guide rod (B) and the caliper (C) up out of the way. Check the hoses and pin boots for damage and deterioration.
4. Remove the pad shims (A), pad retainers (B) and pads (C).

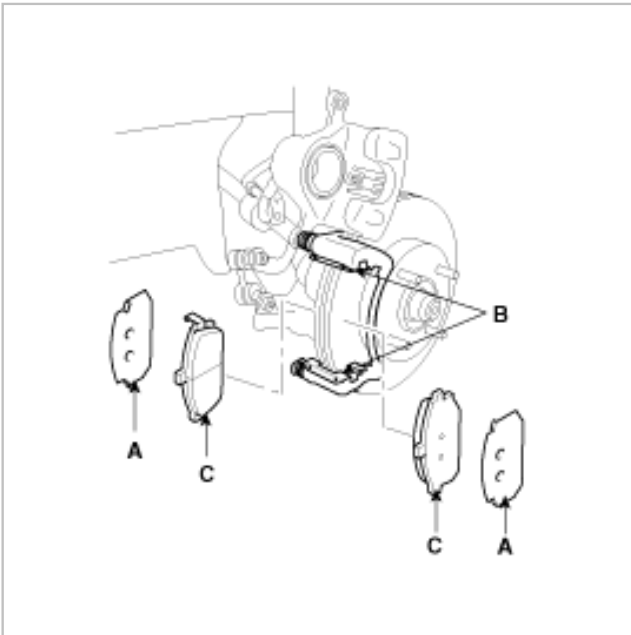

5. Using vernier calipers, measure the thickness of each brake pad lining. The measurement does not include pad backing plate (A) thickness.

**Brake pad thickness:**

11mm (0.43 in.)

2mm (0.079 in.)

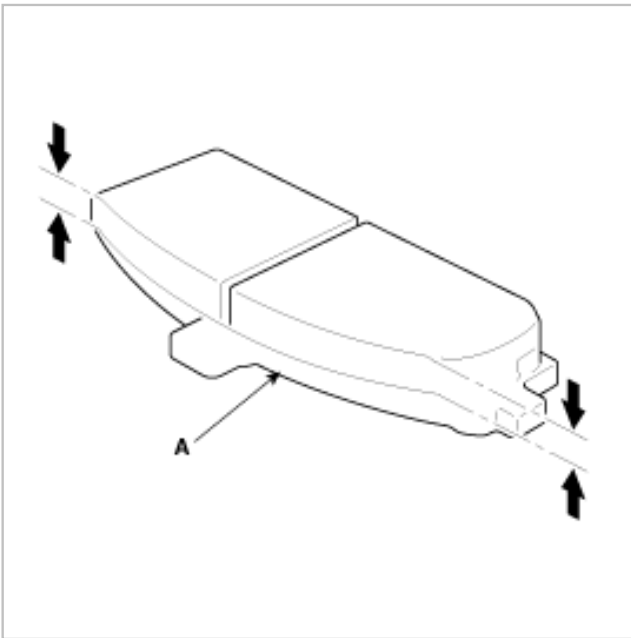

6. If the brake pad thickness is less than service limit, replace the front pads as a set.
7. Clean the caliper thoroughly; remove any rust, and check for grooves and cracks.
8. Check the brake disc for damage and cracks.
9. Install the pad retainers (A).

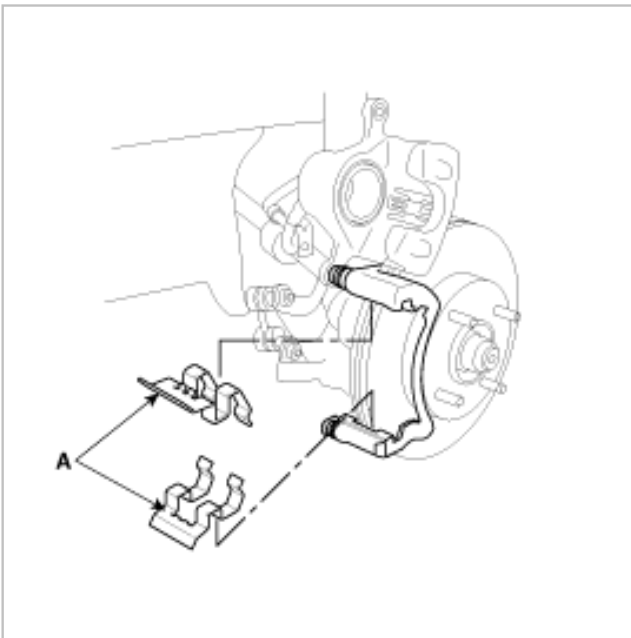

10. Check the foreign material at the pad shims (A) and the back of the pads (B).  
Contaminated brake discs or pads reduce stopping ability. Keep grease off the discs and pads.



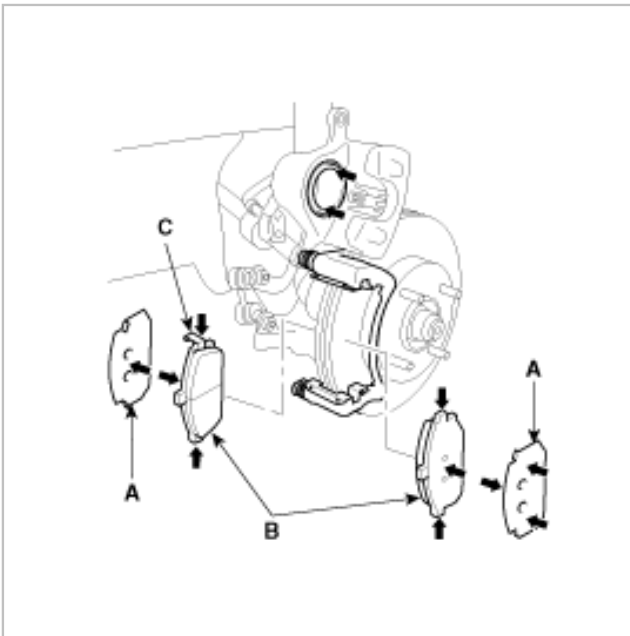

11. Install the brake pads (B) and pad shims (A) correctly. Install the pad with the wear indicator (C) on the inside. If you are reusing the pads, always reinstall the brake pads in their original positions to prevent a momentary loss of braking efficiency.
12. Push in the piston (A) so that the caliper will fit over the pads. Make sure that the piston boot is in position to prevent damaging it when pivoting the caliper down.
13. Pivot the caliper down into position. Being careful not to damage the pin boot, install the guide rod bolt (B) and torque it to proper specification.

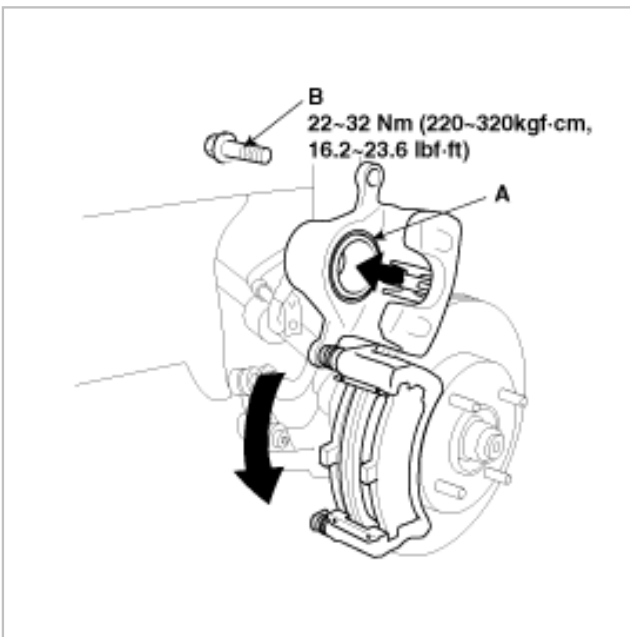

## NOTE

Insert the piston in the cylinder using the special tool (09581-11000).

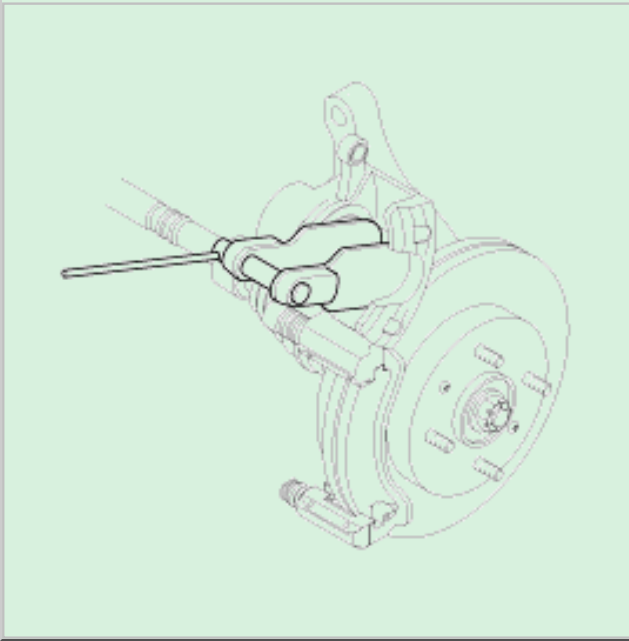

14. Install the brake hose on to the knuckle.
15. Depress the brake pedal several times to make sure the brakes work, then test-drive.

## NOTE

Engagement of the brake may require a greater pedal stroke immediately after the brake pads have been replaced as a set. Several applications of the brake will restore the normal pedal stroke.

16. After installation, check for leaks at hose and line joints or connections, and retighten if necessary.

## INSPECTION

### Runout

1. Loosen the front wheel nuts slightly, then raise the vehicle and make sure it is securely supported.  
Remove the front wheels.
2. Remove the brake pads (see page BR-27).
3. Inspect the disc surface for damage and cracks.  
Clean the disc thoroughly and remove all rust.
4. Use wheel nuts and suitable flat washers (A) to hold the disc securely against the hub, then mount a dial indicator as shown, and measure the runout at 10 mm (0.4 in.) from the outer edge of the disc.

#### **Brake disc runout:**

0.10 mm (0.004 in.)

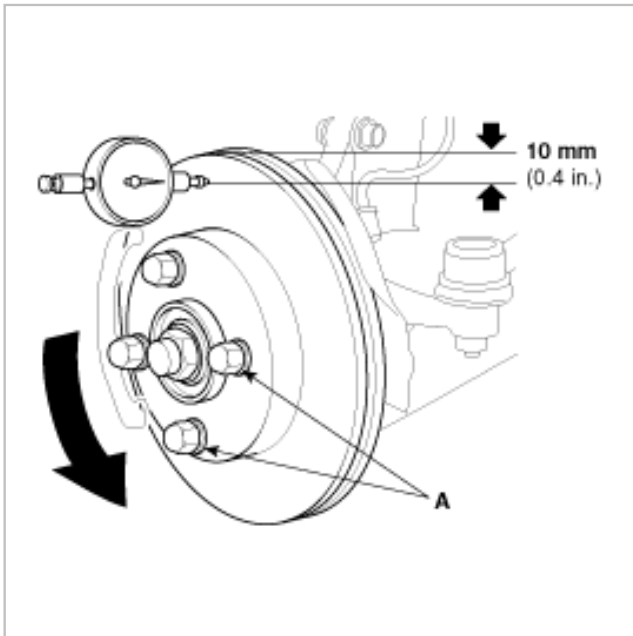

5. If the disc is beyond the service limit, refinish the brake disc with an on-car brake lathe.

22.4 mm (0.882 in.)

#### NOTE

- If the brake disc is beyond the service limit for refinishing, replace it (see page BR-27).
- A new disc should be refinished if its runout is greater than 0.10 mm (0.004 in.).

### Thickness and parallelism

1. Loosen the front wheel nuts slightly, then raise the vehicle and make sure it is securely supported.  
Remove the front wheels.
2. Remove the brake pads (see page BR-27)
3. Using measure disc thickness at eight points, approximately 45° apart and 10 mm (0.4 in.) in from the outer edge of the disc. Replace the brake disc of the smallest measurement is less than the max. refinishing limit.

#### Brake disc thickness:

24 mm (0.945 in.)

22.4 mm (0.882 in.)

Max. 0.015 mm (0.0006 in.)

**NOTE**

This is the maximum allowable difference between the thickness measurements.

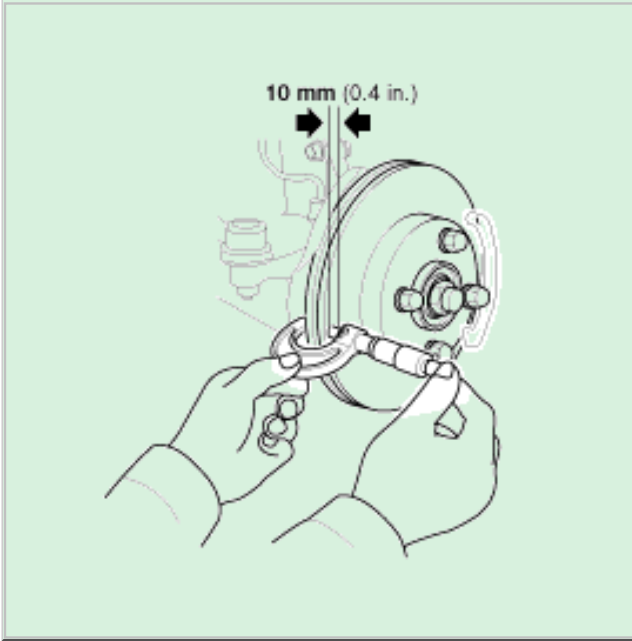

4. If the disc is beyond the service limit for parallelism, refinish the brake disc with an on-car brake lathe.

**NOTE**

If the brake disc is beyond the service limit for refinishing, replace it (see DS group-front axle).