



Replacement

NOTE

Do not spill brake fluid on the vehicle; it may damage the paint; if brake fluid does contact the paint, wash it off immediately with water.

1. Remove the air cleaner cover (A), air filter (B), air cleaner mounting bolts (C) and air cleaner body (D) from the air cleaner mounting bracket (E).

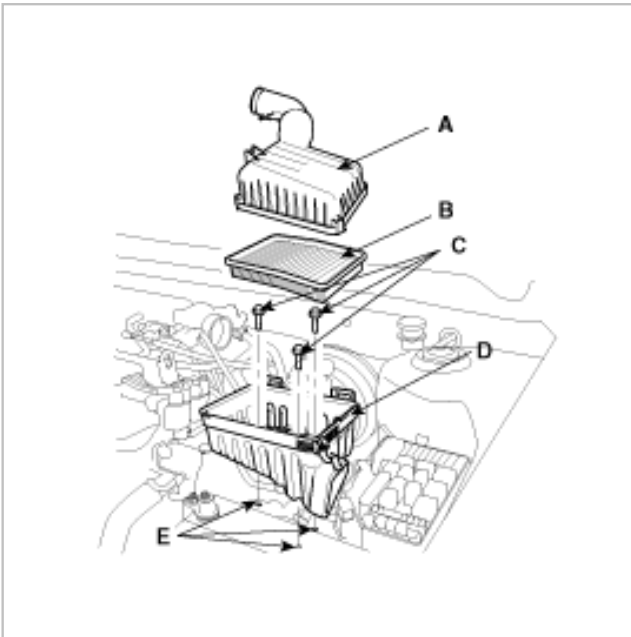

2. Disconnect the brake fluid level switch connectors(A), and remove the reservoir cap(B).

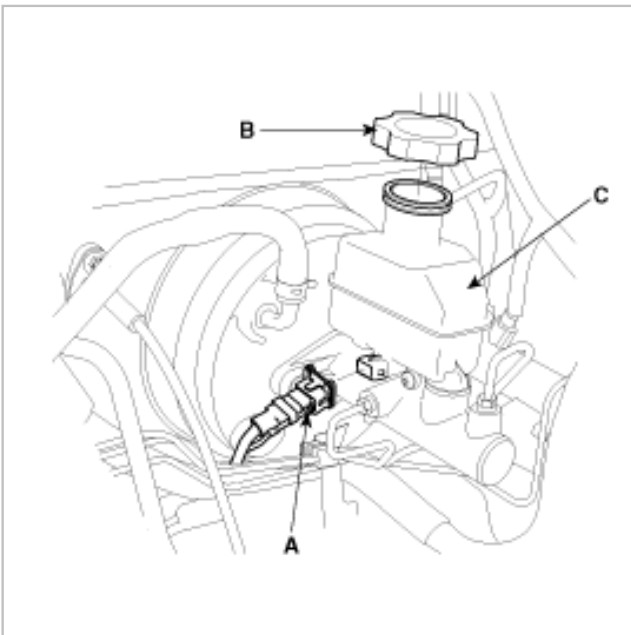

3. Remove the brake fluid from the master cylinder reservoir(C) with a syringe.

4. Disconnect the brake lines(A) from the master cylinder. To prevent spills, cover the hose joints with rags or shop towels.

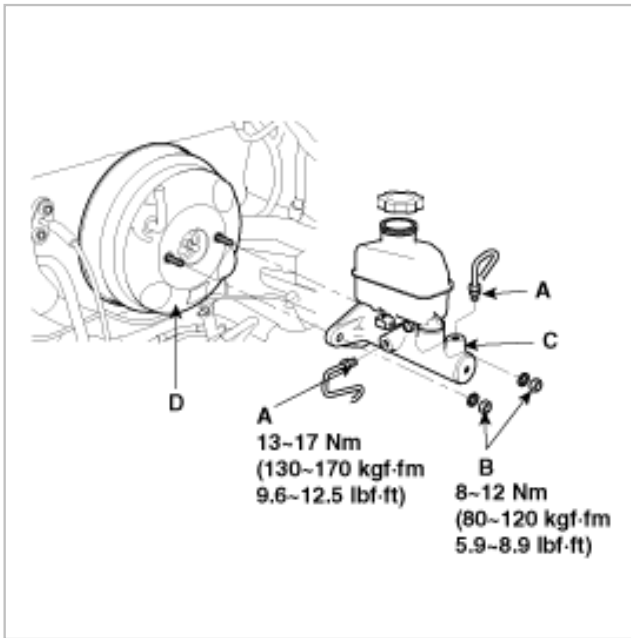

5. Remove the master cylinder mounting nuts(B) and washers.
6. Remove the master cylinder(C) from the brake booster(D). Be careful not to bend or damage the brake lines when removing the master cylinder.
7. Install the master cylinder in the reverse order of removal, and note these items:
 - A. Replace all rubber parts with new ones whenever, removed.

INSPECTION

NOTE

- Before reassembling, check that all parts are free of dust and other foreign particles.
- Do not try to disassemble the master cylinder assembly. Replace the master cylinder assembly with a new part if necessary.
- Do not allow dirt or foreign matter to contaminate the brake fluid.

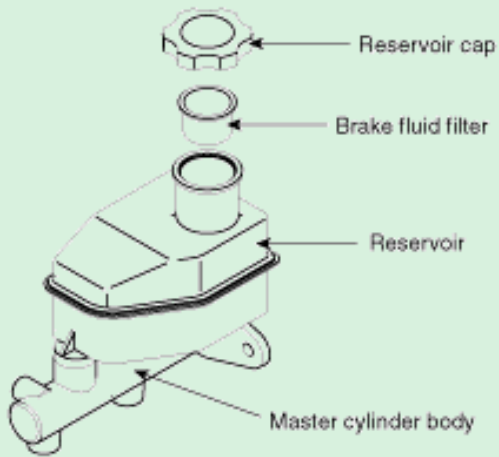

Replacement

NOTE

Do not spill brake fluid on the vehicle; it may damage the paint; if brake fluid does contact the paint, wash it off immediately with water.

1. Remove the air cleaner cover (A), air filter (B), air cleaner mounting bolts (C) and air cleaner body (D) from the air cleaner mounting bracket (E).

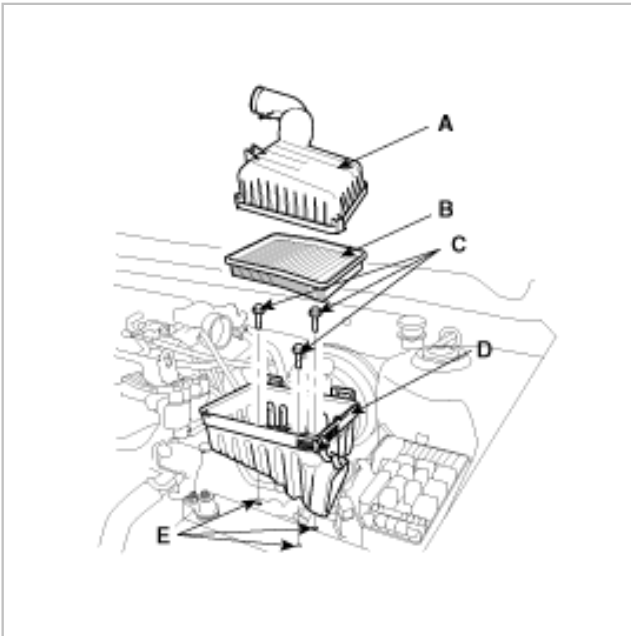

2. Disconnect the brake fluid level switch connectors(A), and remove the reservoir cap(B).

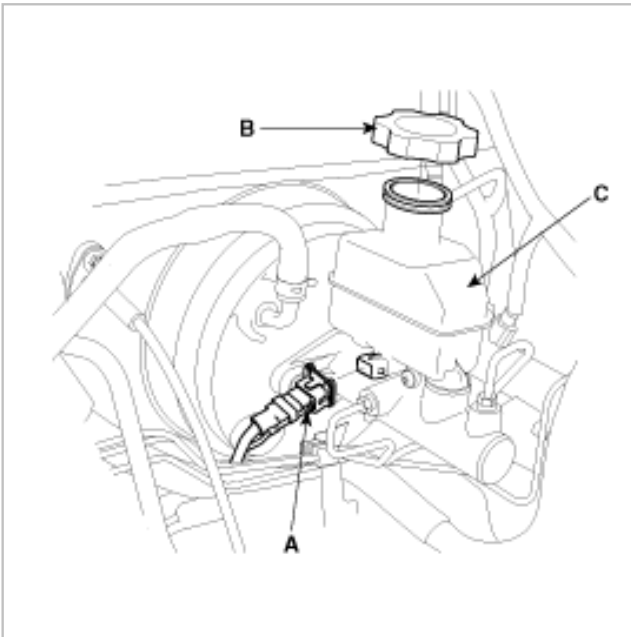

3. Remove the brake fluid from the master cylinder reservoir(C) with a syringe.
4. Disconnect the brake lines(A) from the master cylinder. To prevent spills, cover the hose joints with rags or shop towels.

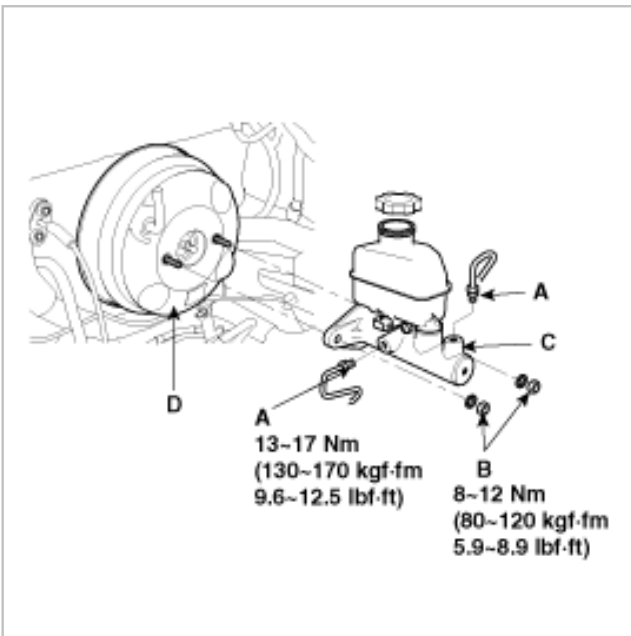

5. Remove the master cylinder mounting nuts(B) and washers.
6. Remove the master cylinder(C) from the brake booster(D). Be careful not to bend or damage the brake lines when removing the master cylinder.
7. Install the master cylinder in the reverse order of removal, and note these items:
 - A. Replace all rubber parts with new ones whenever, removed.

INSPECTION

NOTE

- Before reassembling, check that all parts are free of dust and other foreign particles.
- Do not try to disassemble the master cylinder assembly. Replace the master cylinder assembly with a new part if necessary.
- Do not allow dirt or foreign matter to contaminate the brake fluid.

