

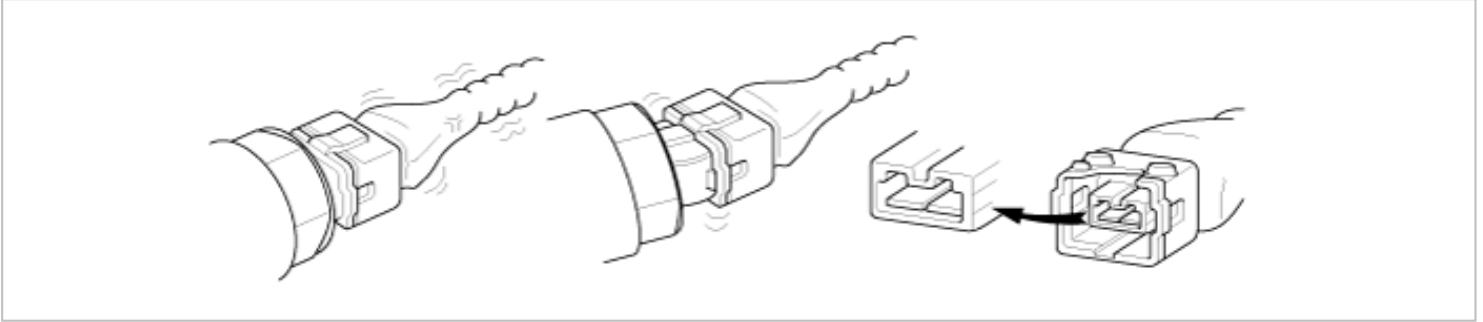

p

INTERMITTENT PROBLEM PROCEDURE

1. Clear diagnostic trouble code(DTC).
2. Inspect connector connection and check terminal for poor connections, loose wires, bent or broken pins and corrosions. Make sure that the connectors are always securely fastened.



3. Perform a simulation test.(See next page)
4. Repair or replace the component that has a problem.
5. Verify that the problem has disappeared with the road test.

ECM PROBLEM PROCEDURE

1. Turn ignition switch to OFF.
2. Disconnect ECM connector, measure the resistance between ground terminal on the ECM side (terminal 1, 2) and chassis ground.

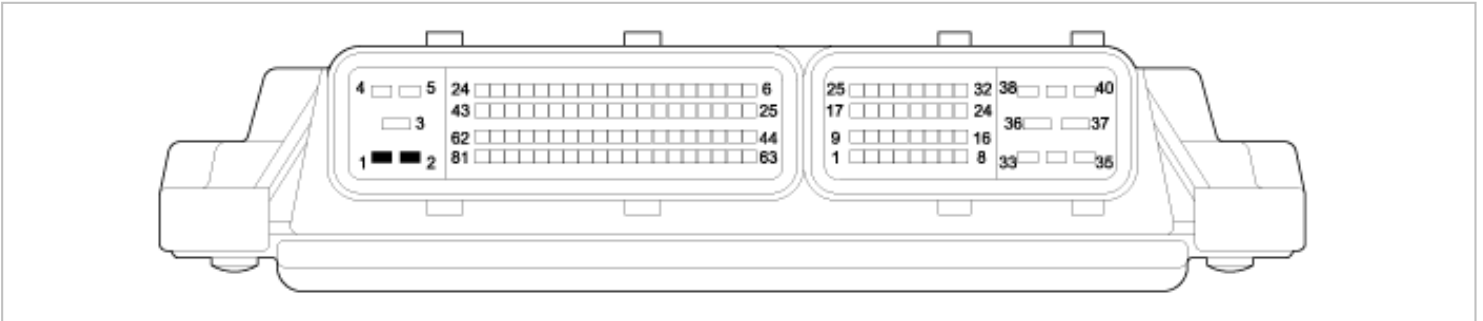

3. Inspect connector connection and check terminal for poor connections, loose wires, bent or broken pins and corrosion.
4. If it is abnormal, repair it. If it is normal, the ECM could be faulty.
5. Temporarily install a good ECM and check for proper operation. If problem disappeared, replace ECM.

SIMULATION TEST

1. Vibration
 - A. Slightly shake the connector and wiring harness up and down and right and left.
 - B. Slightly Vibrate sensors or actuators.
2. Heat
 - A. Heat components that likely caused the malfunction with a hair dryer or others.
 - B. Do not heat the components to the point where they may be damaged and do not heat the ECM directly.
3. Water sprinkling
 - A. Sprinkle water onto vehicle to simulate a rainy day or a high humidity condition.
 - B. In this test, do not sprinkle water directly onto the engine compartment or electronic components.

4. Electrical loads

A. Turn on all electrical systems to simulate excessive electrical loads.

MFI SYSTEM INSPECTION

1. Engine is hard to start or does not start at all.
2. Unstable idle.
3. Poor driveability.

NOTE

- Before removing or installing any parts, read the diagnostic trouble codes and then disconnect the battery negative (-) terminal.
- Before disconnecting the cable from the battery terminal, turn the ignition switch to the OFF position. Removal or connection of the battery cable during engine operation or while the ignition switch is ON could cause damage to the ECM.
- The control harnesses between the ECM and heated oxygen sensor are shielded with the shielded ground wires to the body in order to prevent the influence of ignition noises and radio signals. When the shielded wire is faulty, the control harness must be replaced.
- When checking the generator for charging ability, do not disconnect the battery '+' terminal to prevent the ECM from being damaged.
- When charging the battery with the external charger, disconnect the battery terminals from the vehicle to prevent damage to the ECM.

MALFUNCTION INDICATOR LAMP (MIL)

- Catalyst
- Fuel system
- Mass Air Flow (MAF) Sensor
- Intake Air Temperature Sensor (Built in MAF Sensor)
- Engine Coolant Temperature Sensor
- Throttle Position Sensor
- Upstream Oxygen Sensor
- Downstream Oxygen Sensor Heater
- Downstream Oxygen Sensor
- Upstream Oxygen Sensor Heater
- Injector
- Misfire
- Crankshaft Position Sensor
- Camshaft Position Sensor
- Evaporative Emission Control System
- Vehicle Speed Sensor
- Idle Control Valve
- Power Supply
- ECM
- MT/AT Encoding
- MIL-on Request Signal
- Power Stage
- Differential Pressure Sensor

- Canister Close Valve
- Continuously Variable Valve Timing System

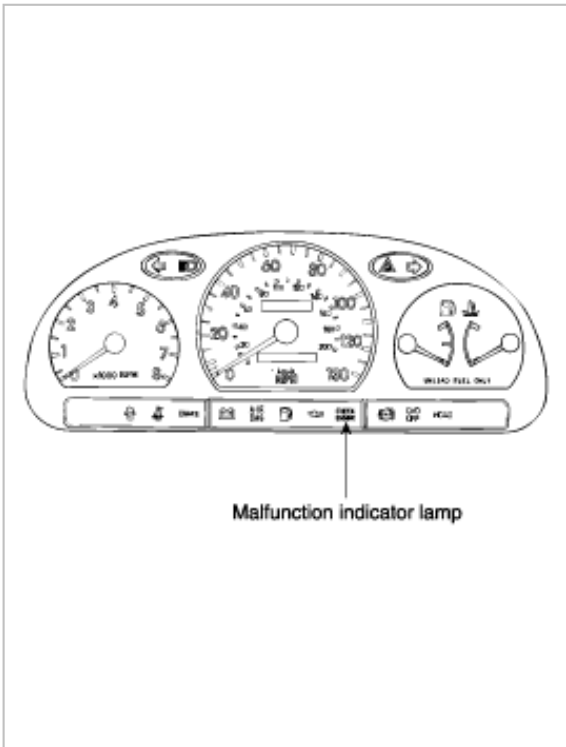

[INSPECTION]

1. After turning ON the ignition key, ensure that the light illuminates before engine starts and then goes out.
2. If the light does not illuminate, check for an open circuit in the harness, a blown fuse or a blown bulb.

NOTE

If a sensor connector is disconnected with the ignition switch turned on, the diagnostic trouble code (DTC) is recorded. In this case, disconnect the battery negative terminal (-) for 15 seconds or more, and the diagnosis memory will be erased.

THE RELATION BETWEEN DTC AND DRIVING PATTERN IN EOBD SYSTEM

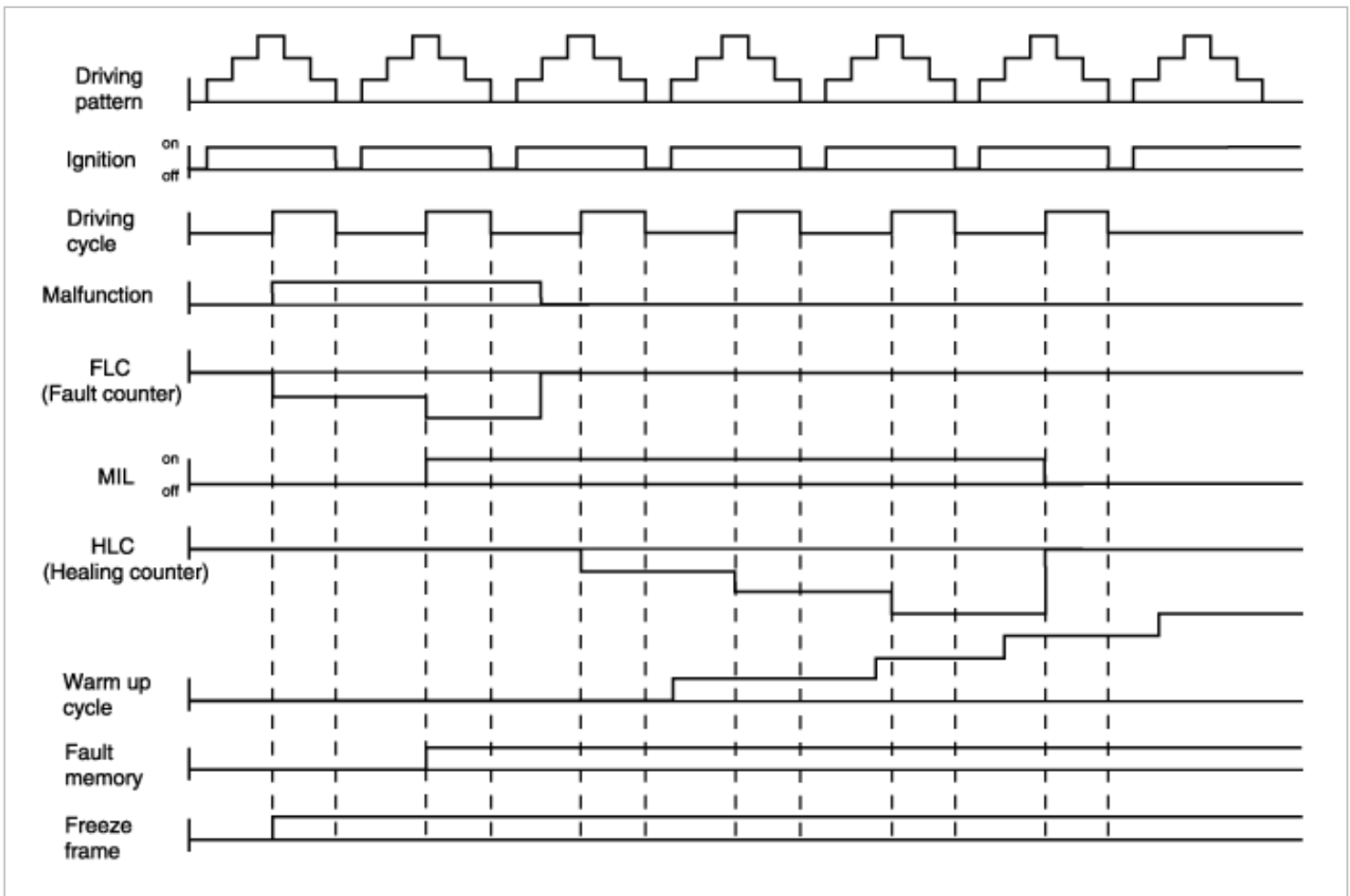

1. When the same malfunction is detected and maintained during two sequential driving cycles, the MIL will automatically illuminate.
2. The MIL will go off automatically if no fault is detected after 3 sequential driving cycles.
3. A Diagnostic Trouble Code (DTC) is recorded in ECM memory when a malfunction is detected after two sequential driving cycles.
4. The MIL will illuminate when the malfunction is detected on the second driving cycle.
If a misfire is detected, a DTC will be recorded and the MIL will illuminate immediately after a fault is first detected.
5. A Diagnostic Trouble Code (DTC) will automatically be erased from the ECM memory if the same malfunction is not detected for 40 driving cycles.

NOTE

- A "warm-up cycle" means sufficient vehicle operation such that the coolant temperature has risen by at least 40 degrees Fahrenheit from engine starting and reaches a minimum temperature of 160 degrees Fahrenheit.
- A "driving cycle" consists of engine startup, vehicle operation beyond the beginning of closed loop operation.

INSPECTION CHART FOR DIAGNOSTIC TROUBLE CODES (DTC)

DTC NO	DESCRIPTION	CAL	FED	SEE PAGE
P0010	"A" Camshaft Position Actuator Circuit (Bank 1)			FL-43
P0030	HO2S Heater Control Circuit (Bank 1 / Sensor 1)			FL-44
P0031	HO2S Heater Circuit low (Bank 1 / Sensor 1)	O	O	FL-49
P0032	HO2S Heater Circuit high (Bank 1 / Sensor 1)			FL-52

P0036	HO2S Heater Control Circuit (Bank 1 / Sensor 2)			FL-55
P0037	HO2S Heater Circuit low (Bank 1 / Sensor 2)			FL-59
P0038	HO2S Heater Circuit high (Bank 1 / Sensor 2)			FL-62
P0076	Intake Valve Control Solenoid Circuit Low (Bank1)			FL-65
P0077	Intake Valve Control Solenoid Circuit High (Bank1)			FL-69
P0101	Mass Air Flow Circuit Range/Performance			FL-72
P0102	Mass Air Flow Circuit Low Input			FL-77
P0103	Mass Air Flow Circuit high Input			FL-80
P0112	Intake Air Temperature Sensor Circuit Low Input			FL-82
P0113	Intake Air Temperature Sensor Circuit High Input			FL-86
P0116	Engine Coolant Temperature Circuit Range/ Performance			FL-89
P0117	Engine Coolant Temperature Circuit Low Input			FL-92
P0118	Engine Coolant Temperature Circuit High Input			FL-95
P0121	Throttle Position Sensor Circuit Range/Performance			FL-101
P0122	Throttle Position Sensor Circuit Low Input			FL-105
P0123	Throttle Position Sensor Circuit High Input			FL-108
P0125	Insufficient Coolant Temperature for Closed Loop Fuel Control			FL-111
P0128	Coolant Thermostat (Coolant Temp. below Thermostat Regulating Temp.)			FL-113
P0131	O2 Sensor Circuit Low Voltage(Bank 1 / Sensor 1)			FL-115
P0132	O2 Sensor Circuit High Voltage(Bank 1 / Sensor 1)			FL-118
P0133	O2-Sensor Circuit Slow Response (Bank 1 / Sensor 1)			FL-120
P0136	O2 Sensor Circuit (Bank 1 / Sensor 2)			FL-122
P0137	O2 Sensor Circuit Low Voltage (Bank 1 / Sensor 2)			FL-125
P0138	O2 Sensor Circuit High Voltage (Bank 1 / Sensor 2)			FL-127
P0139	O2 Sensor Circuit Slow Response			FL-129
P0140	O2 Sensor Circuit No Activity Detected (Bank 1 / Sensor 2)			FL-131
P0171	System Too Lean (Bank 1)			FL-134
P0172	System Too Rich (Bank 1)			FL-138
P0196	Engine Oil Temp. Sensor Range / Performance			FL-141
P0197	Engine Oil Temp. Sensor Low Input			FL-144
P0198	Engine Oil Temp. Sensor High Input			FL-147

P0261	Cylinder 1 - Injector Circuit Low			FL-154
P0262	Cylinder 1 - Injector Circuit High			FL-158
P0264	Cylinder 2 - Injector Circuit Low			FL-161
P0265	Cylinder 2 - Injector Circuit High			FL-164
P0267	Cylinder 3 - Injector Circuit Low			FL-167
P0268	Cylinder 3 - Injector Circuit High			FL-170
P0270	Cylinder 4 - Injector Circuit Low			FL-173
P0271	Cylinder 4 - Injector Circuit High			FL-176
P0300	Random/Multiple Cylinder Misfire Detected			FL-179
P0301	Cylinder 1 - Misfire detected			FL-183
P0302	Cylinder 2 - Misfire detected			FL-187
P0303	Cylinder 3 - Misfire detected			FL-194
P0304	Cylinder 4 - Misfire detected			FL-198
P0325	Knock Sensor Circuit	Δ	Δ	FL-202
P0335	Crankshaft Position Sensor Circuit			FL-206
P0340	Camshaft Position Sensor Circuit Malfunction(Single Sensor)			FL-211
P0341	Camshaft Position Sensor Circuit Range/Performance (Single Sensor)			FL-216
P0420	Catalyst System Efficiency below Threshold (Bank 1)			FL-217
P0441	Evap. Emission System Incorrect Purge Flow			FL-220
P0442	Evap. Emission System - Leak detected (small leak)			FL-222
P0444	Evap. Emission System - Purge Ctrl. Valve Circuit Open			FL-226
P0445	Evap. Emission System - Purge Ctrl. Valve Circuit Shorted			FL-230
P0447	Evap. Emission System - Vent Control Circuit Open			FL-233
P0448	Evap. Emission System - Vent Control Circuit Shorted			FL-236
P0449	Evap. Emission System - Vent valve / Solenoid circuit			FL-239
P0451	Evap. Emission System - Pressure Sensor Range / Performance			FL-241
P0452	Evap. Emission System - Pressure Sensor Low Input			FL-244
P0453	Evap. Emission System - Pressure Sensor High Input			FL-246
P0454	Evap. Emission System - Pressure Sensor Intermittent			FL-249
P0455	Evap. Emission System - Leak detected (large leak)			FL-252

P0456	Evap. Emission System - Leak detected (very small leak)			FL-255
P0501	Vehicle Speed Sensor Range/Performance			FL-258
P0506	Idle Air Control System - RPM lower than expected			FL-261
P0507	Idle Air Control System - RPM higher than expected			FL-266
P0560	System Voltage	Δ	Δ	FL-270
P0562	System Voltage Low			FL-273
P0600	CAN Communication BUS			FL-275
P0605	Internal Control Module Read Only Memory(ROM) Error			FL-276
P0606	ECM/PCM Processor (ECU-SELF TEST Failed)			FL-277
P0650	Malfunction Indicator Lamp(MIL) Control Circuit	Δ	Δ	FL-278
P1166	O2 Sensor System - Lambda Controller at the Limit			FL-281
P1372	Misfire Detection - Segment Time Acquisition Incorrect	Δ	Δ	FL-284
P1505	Idle Speed Actuator Signal Low of Coil #1			FL-289
P1506	Idle Speed Actuator Signal High of Coil #1			FL-293
P1507	Idle Speed Actuator Signal Low of Coil #2			FL-296
P1508	Idle Speed Actuator Signal High of Coil #2			FL-299
P1529	TCU Request for MIL On			FL-302
P1602	CAN Communication BUS with TCU (Timeout)			FL-303
P1690	Immobilizer Smartra Error		Δ	FL-306
P1691	Immobilizer Antena Error		Δ	FL-306
P1693	Immobilizer Transponder Error		Δ	FL-306
P1694	Immobilizer ECU Siganl Error		Δ	FL-306
P1695	Immobilizer EEPROM Error		Δ	FL-306
P1696	Immobilizer Mismatch/Overtrial Error		Δ	FL-306
P2096	Post Catalyst Fuel Trim System Too Lean Bank 1			FL-310
P2097	Post Catalyst Fuel Trim System Too Rich Bank 1			FL-310
P2195	O2 Sensor Signal Stuck Lean -Bank 1 Sensor 1			FL-312
P2196	O2 Sensor Signal Stuck Rich -Bank 1 Sensor 1			FL-312
P2231	O2 Sensor Signal Circuit Shorted to Heater Circuit (Bank 1 Sensor 1)			FL-314
P2237	O2 Sensor Pumping Current Circuit/Open - Bank 1 Sensor 1			FL-316

P2243	O2 Sensor Reference Voltage Circuit/Open - Bank 1 Sensor 1		FL-316
P2251	O2 Sensor Reference Ground Circuit/Open - Bank 1 Sensor 1		FL-316
P2270	O2 Sensor Signal Stuck Lean - Bank 1 Sensor 2		FL-318
P2271	O2 Sensor Signal Stuck Rich - Bank 1 Sensor 2		FL-318
P2414	O2 Sensor Exhaust Sample Error - Bank 1 Sensor 1		FL-320
P2626	O2 Sensor Pumping Current Trim Circuit/Open - Bank 1 Sensor 1		FL-316

NOTE
 : MIL ON & FAULT CODE MEMORY
 Δ : MIL OFF & FAULT CODE MEMORY

SUSPECT AREA RELATED TO DTC

NOTE
 Suspect areas for each diagnostic item do not list all probable causes.

DTC No.	Diagnostic items	Suspect area
P0030	O2 Sensor Heater - Heater Control Circuit (Bank 1 / Sensor 1)	<ul style="list-style-type: none"> •Contaminated, deteriorated or aged HO2S •Heater Resistance out of Reasonable Range •Misplaced, bent, loose or corroded connector terminals •Faulty HO2S
P0031	O2 Sensor Heater Circuit low (Bank 1 / Sensor 1)	<ul style="list-style-type: none"> •Blown or missing HO2S fuse •Open or short to GND between HO2S and ECM •Faulty HO2S
P0032	O2 Sensor Heater Circuit high (Bank 1 / Sensor 1)	<ul style="list-style-type: none"> •Short to battery between HO2S and ECM •Faulty HO2S
P0136	O2 Sensor Circuit Malfunction(Bank 1 / Sensor 2)	<ul style="list-style-type: none"> •Short between rear HO2S and ECM •Faulty rear HO2S
P0137	O2 Sensor Circuit Low Input (Bank 1 / Sensor 2)	<ul style="list-style-type: none"> •Short to GND between HO2S and ECM •Faulty front HO2S
P0138	O2 Sensor Circuit High Input (Bank 1 / Sensor 2)	<ul style="list-style-type: none"> •Open or short to battery between HO2S and ECM •Faulty front HO2S

<p>P0139</p>	<p>O2 Sensor Circuit Slow Response (Bank 1 / Sensor 2)</p>	<ul style="list-style-type: none"> •Front and rear HO2S connections reversed •Faulty fuel delivery system •Leak in intake system •Leak in exhaust system •Faulty MAPS ground circuit •Faulty HO2S <p>NOTE</p> <p>If any misfire, purge solenoid valve, MAPS or HO2S heater codes are present, do all repairs associated with those codes before proceeding with this trouble area.</p>
<p>P0140</p>	<p>O2 Sensor Circuit No Activity Detected (Bank 1 / Sensor 2)</p>	<ul style="list-style-type: none"> •Contaminated, deteriorated or aged HO2S •Misplaced, bent, loose or corroded connector terminals •Faulty HO2S <p>NOTE</p> <p>If any misfire, purge solenoid valve or HO2S heater codes are present, do all repairs associated with those codes before proceeding with this trouble area.</p>
<p>P0037</p>	<p>O2 Sensor Heater Circuit low (Bank 1 / Sensor 2)</p>	<ul style="list-style-type: none"> •Blown or missing HO2S fuse •Open or short to GND between HO2S and ECM •Faulty HO2S
<p>P0038</p>	<p>O2 Sensor Heater Circuit high (Bank 1 / Sensor 2)</p>	<ul style="list-style-type: none"> •Short to battery between HO2S and ECM •Faulty HO2S
<p>P0036</p>	<p>O2 Sensor Heater - Heater Control Circuit (Bank 1 / Sensor 2)</p>	<ul style="list-style-type: none"> •Contaminated, deteriorated or aged HO2S •Heater resistance out of reasonable range •Misplaced, bent, loose or corroded connector terminals •Faulty HO2S
<p>P0106</p>	<p>MAP Sensor-Rationality</p>	<ul style="list-style-type: none"> •Dirty air cleaner •Oil cap or dipstick missing or not installed correctly •Air leak in intake system •Contaminated, deteriorated or damaged manifold absolute pressure sensor •Faulty manifold absolute pressure sensor or throttle position sensor •Poor connections between ECM and MAP or TPS

		<p>NOTE</p> <p>If any codes relating to MAP are present, do all repairs associated with them before proceeding with this troubleshooting area.</p>
P0107	MAP Sensor-Range Check Low	<ul style="list-style-type: none"> •Short to ground between MAP and ECM •Signal line open between MAP and ECM •Faulty MAP
P0108	MAP Sensor-Range Check High	<ul style="list-style-type: none"> •Short to Battery between MAP and ECM •Ground open between MAP and main relay •Ground open or Poor connections between open or short to battery between MAP and ECM •Faulty MAP
P0112	Intake Air Temperature Circuit Low Input	<ul style="list-style-type: none"> •Short to ground between IAT sensor and ECM •Short between IAT sensor wires •Faulty IAT sensor
P0113	Intake Air Temperature Circuit High Input	<ul style="list-style-type: none"> •Open or short to battery between IAT sensor and ECM •Faulty IAT sensor
P0116	Engine Coolant Temperature Circuit Range / Performance	<ul style="list-style-type: none"> •After engine start-up, the measured coolant temperature shows no variation after detecting the calculated coolant temperature variation (engine coolant temperature sensor input is stuck.) •Poor connections between ECT sensor and ECM •Misplaced, loose or corroded terminals •Foreign materials fouled ECTS •Faulty ECTS <p>NOTE</p> <p>If any codes relating to ECTS are present, do all repairs associated with them before proceeding with this troubleshooting area.</p>
P0117	Engine Coolant Temperature Circuit Low Input	<ul style="list-style-type: none"> •Short to ground between ECTS and ECM •Short between ECTS wires •Faulty ECTS
P0118	Engine Coolant Temperature Circuit High Input	<ul style="list-style-type: none"> •Open or short to battery between ECTS and ECM •Faulty ECTS

P0121	Throttle / Pedal Position Circuit Range/ Performance Problem	<ul style="list-style-type: none"> •Poor connections between TPS and ECM •Misplaced, loose or corroded terminals •Contaminated deteriorated TPS •Open or short between TPS 5V reference and ECM •Open or short between TPS signal and ECM •Short between TPS wires •Faulty TPS
P0122	Throttle / Pedal Position Circuit Low Input	<ul style="list-style-type: none"> •Short to GND between TPS and ECM •Open / Short to GND between TPS and ECM •Short to GND between ECM and fuel tank pressure sensor (FTPS) •Faulty TPS or FTPS
P0123	Throttle / Pedal Position Circuit High Input	<ul style="list-style-type: none"> •Open or short to battery between TPS and ECM •Open between and ECM •Faulty TPS
P0125	Insufficient Coolant Temperature for Closed Loop Fuel Control	<ul style="list-style-type: none"> •After engine start-up, the elapsed time before feedback operation is initializes too long (engine coolant temperature sensor input is insufficient for closed loop operation) •Poor connections between ECT sensor and ECM •Faulty ECTS •Thermostat
P0128	Coolant Thermostat (Coolant Temp. below Thermostat Regulating Temp.)	<ul style="list-style-type: none"> •Thermostat stuck opened
P0131	O2 Sensor Circuit Low Input(Bank 1 / Sensor 1)	<ul style="list-style-type: none"> •Short to GND between HO2S and ECM •Faulty front HO2S
P0132	O2 Sensor Circuit High Input(Bank 1 / Sensor 1)	<ul style="list-style-type: none"> •Short to battery between HO2S and ECM •Faulty front HO2S
P0133	O2-Sensor Circuit Slow Response (Bank 1 / Sensor 1)	<ul style="list-style-type: none"> •Front and rear HO2S connections reversed •Faulty fuel delivery system •Leak in intake system •Leak in exhaust system •Faulty MAPS ground circuit •Faulty HO2S <div style="background-color: #e0ffe0; padding: 5px; border: 1px solid #ccc; margin-top: 10px;"> <p>NOTE</p> <p>If any misfire, purge solenoid valve, MAPS or HO2S heater codes are present, do all repairs associated with those codes before proceeding with this trouble area.</p> </div>

P0134	O2 Sensor Circuit No Activity Detected (Bank 1 / Sensor 1)	<ul style="list-style-type: none"> •Contaminated, deteriorated or aged HO2S •Misplaced, bent, loose or corroded connector terminals •Faulty HO2S <p>NOTE</p> <p>If any misfire, purge solenoid valve or HO2S heater codes are present, do all repairs associated with those codes before proceeding this trouble area.</p>
P0171	Fuel Trim Malfunction - System Too Lean (Bank 1)	<ul style="list-style-type: none"> •Faulty ignition system (Ignition coil/spark plug/ Ignition cable) •Faulty fuel delivery system (Fuel tank/Pressure regulator/Canister purge valve) •Clogged fuel injectors •Faulty fuel injectors •Leak in intake system •Leak in exhaust system •Faulty MAPS <p>NOTE</p> <p>If any codes relating to injectors, HO2S, ECTS or MAPS are stored, do all repairs associated with those codes before proceeding with this trouble area.</p>
P0172	Fuel Trim Malfunction - System Too Rich (Bank 1)	<ul style="list-style-type: none"> •Faulty fuel delivery system (Fuel tank/Pressure regulator/Canister purge valve) •Faulty fuel injectors •Faulty MAPS <p>NOTE</p> <p>If any codes relating to injectors, HO2S, ECTS or MAPS are stored, do all repairs associated with those codes before proceeding with this trouble area.</p>
P0230	Fuel Pump Circuit Malfunction	<ul style="list-style-type: none"> •Blown or missing fuse/relay •Short to battery between fuel pump relay and ECM •Open between fuel pump relay and ECM •Faulty fuel pump relay
P0261	Cylinder 1 - Injector Circuit Low	<ul style="list-style-type: none"> •Short to GND between injector and ECM
P0264	Cylinder 2 - Injector Circuit Low	<ul style="list-style-type: none"> •Faulty fuel injector
P0267	Cylinder 3 - Injector Circuit Low	
P0270	Cylinder 4 - Injector Circuit Low	
P0262	Cylinder 1 - Injector Circuit High	<ul style="list-style-type: none"> •Open between injector fuse and injector •Open or short to battery between injector and ECM

P0265	Cylinder 2 - Injector Circuit High	<ul style="list-style-type: none"> •Faulty fuel injector
P0268	Cylinder 3 - Injector Circuit High	
P0271	Cylinder 4 - Injector Circuit High	
P0300	Multiple Cylinder Misfire Detected	<ul style="list-style-type: none"> •Vacuum leak in air intake system •CKP sensor circuit malfunction •Faulty CKP sensor •Ignition circuit malfunction •Faulty ignition coil or plug wire •Spark plug malfunction •Low compression due to blown head gasket, leaking valve or piston ring •Low/high fuel pressure due to faulty pressure regulator, restricted fuel lines, plugged fuel filter or faulty fuel pump •Fuel injector circuit malfunction •Faulty fuel injector
P0301	Cylinder 1 - Misfire detected	
P0302	Cylinder 2 - Misfire detected	
P0303	Cylinder 3 - Misfire detected	
P0304	Cylinder 4 - Misfire detected	
		<p>NOTE</p> <p>If any fuel injector codes (or pending codes) are present, do all repairs associated with those codes before proceeding with this trouble area.</p>
P0325	Knock Sensor 1 Circuit Malfunction	<ul style="list-style-type: none"> •Open or short to GND between knock sensor and ECM •Source of high resistance between knock sensor and ECM •Faulty knock sensor
P0335	Crankshaft Position Sensor Circuit Malfunction	<ul style="list-style-type: none"> •Short to GND between CKP sensor and ECM •Open or short to battery between CKP and ECM •Short between CKP sensor wires •Poor connection between CKP connector harness connector •Out of spec air gap •Faulty target wheel tolerance •Faulty CKP sensor
P0340	Camshaft Position Sensor Circuit Malfunction(Bank1 or Single Sensor)	<ul style="list-style-type: none"> •Short to GND between CMP sensor and ECM •Open or short to battery between CMP and ECM •Short between CMP sensor wires •Poor connection between CMP connector harness connector •Faulty CMP sensor

P0420	Catalyst System Efficiency below Threshold (Bank 1)	<ul style="list-style-type: none"> •Catalytic converter deteriorated <div style="background-color: #e0f2f1; padding: 5px; border: 1px solid #ccc;"> <p style="text-align: center; margin: 0;">NOTE</p> <p>If any codes relating to HO2S sensor. MAPS, injectors, a P0170 or a P0173 are present, do all repairs associated with them before proceeding with this trouble area.</p> </div>
P0441	Evap. Emission Ctrl. System Incorrect Purge Flow	<ul style="list-style-type: none"> •Stuck in valve open position
P0442	Evap. Emission Ctrl. System - Small Leak detected (1.0 mm)	<ul style="list-style-type: none"> •Fuel filler cap loose or missing •Fuel filler cap o-ring missing or damaged •Faulty or damaged fuel filler pipe •Leaking, disconnected or plugged fuel vapor lines •Fuel in lines due to faulty rollover valve, on-board refueling vapor recovery valve or CCV stuck closed •Canister close valve clogged, stuck open or closed •Improperly installed purge solenoid valve •PCSV stuck open or closed •Faulty fuel tank pressure sensor •Leaking canister or catch tank <div style="background-color: #e0f2f1; padding: 5px; border: 1px solid #ccc;"> <p style="text-align: center; margin: 0;">NOTE</p> <p>If any codes relating to FTPS, CCV or PCSV circuits are present, do all repairs associated with those codes before proceeding with this trouble area.</p> </div>
P0444	Evap. Emission Ctrl. System - Purge Ctrl. Valve Circuit Open	<ul style="list-style-type: none"> •Faulty PCSV •Open between PCSV and ECM
P0445	Evap. Emission Ctrl. System - Purge Ctrl. Valve Circuit Shorted	<ul style="list-style-type: none"> •Faulty PCSV •Short to GND or battery between PCSV and ECM
P0447	Evap. Emission Ctrl. System - Vent Circuit Open (SOV)	<ul style="list-style-type: none"> •Open or short to battery between CCV and ECM •Faulty CCV
P0448	Evap. Emission Ctrl. System - Vent Circuit Shorted (SOV)	<ul style="list-style-type: none"> •Short to GND between CCV and ECM •Faulty CCV
P0451	Evap. Emission Ctrl. System - Pressure Sensor Range / Performance(DTP_CON)	<ul style="list-style-type: none"> •Canister close valve stuck closed •Blocked vapor hose between canister and CCV •Open or short to battery between FTPS and ECM •Faulty FTPS
P0452	Evap. Emission Ctrl. System - Pressure Sensor Low Input	<ul style="list-style-type: none"> •Short to GND between FTPS and ECM •Faulty FTPS

P0453	Evap. Emission Ctrl. System - Pressure Sensor High Input	<ul style="list-style-type: none"> •Open or short to battery between fuel tank pressure sensor and ECM •Short to battery in ECM •Open in ECM •Faulty FTPS
P0454	Evap.Emission Ctrl. System - Pressure Sensor Intermittent(DTP_NOISE)	<ul style="list-style-type: none"> •Poor connections between FTPS and ECM •Misplaced, loose or corroded terminals •Foreign materials fouled FTPS •Faulty FTPS
P0455	Evap. Emission Ctrl. System - Large Leak detected(or tank cap loose/off)	<ul style="list-style-type: none"> •Fuel filler cap loose or missing •Fuel filler cap o-ring missing or damaged •Faulty or damaged fuel filler pipe •Leaking, disconnected or plugged fuel vapor lines •Fuel in lines due to faulty rollover valve, on-board refueling vapor recovery valve or CCV stuck closed •Canister close valve clogged, stuck open or closed •Improperly installed purge solenoid valve •PCSV stuck open or closed •Faulty fuel tank pressure sensor •Leaking canister or catch tank
P0456	Evap. Emission Ctrl. System- Small Leak detected (0.5 mm)	<div style="background-color: #e0f0e0; padding: 5px; border: 1px solid #ccc;"> <p style="text-align: center; margin: 0;">NOTE</p> <p>-If any codes relating to FTPS, CCV or PCSV circuits are present, do all repairs associated with those codes before proceeding with this trouble area.</p> <p>-If DTC P0455 is stored and MIL is illuminated, before proceeding to evaporative system test and repair, verify whether the customer was running the engine uring refueling.</p> <p>-If an obvious cause for DTC P0455 is an engine running during refueling, erasethe DTC P0455 using the Hi-Scan and do not repair the evaporative system. However, the vehicle should be monitored in case of reoccurrence of the concern which may come from actual evaporative system.</p> </div>
P0501	Vehicle Speed Sensor Range / Performance	<ul style="list-style-type: none"> •Open between fuse and wheel speed sensor (WSS) •Open between WSS and GND •Open between WSS and ECM •Short to battery or GND between WSS and ECM •Faulty WSS

P0506	Idle Control System - RPM lower than expected	<ul style="list-style-type: none"> •High resistance between injector fuse and IAC valve •High resistance between ISC and ECM •Faulty ISC valve •Carbon fouled throttle plate <div style="background-color: #e0f2f1; padding: 5px; border: 1px solid #ccc; margin-top: 10px;"> <p style="text-align: center; margin: 0;">NOTE</p> <p>If any TPS, MAPS, fuel injector or ISC valve circuit codes (or pending codes) are present, do all repairs associated with them before proceeding with this trouble area.</p> </div>
P0507	Idle Control System - RPM higher than expected	<ul style="list-style-type: none"> •Improperly adjusted accelerator cable •Air leak in intake system between head and throttle plate •Faulty PCV valve or PCSV •Poor connections in TPS circuit or faulty TPS •High resistance between IAC valve and ECM •Faulty IAC valve <div style="background-color: #e0f2f1; padding: 5px; border: 1px solid #ccc; margin-top: 10px;"> <p style="text-align: center; margin: 0;">NOTE</p> <p>If any codes relating to TPS, MAPS, fuel injector or ISC valve are present, do all repairs associated with them before proceeding with this troubleshooting area.</p> </div>
P0560	System Voltage Malfunction	<ul style="list-style-type: none"> •Short between main relay and ECM •Open between main relay and ECM •Poor connection •Faulty main relay
P0562	System Voltage Low	<ul style="list-style-type: none"> •Reverse battery cable connection (+/- reverse) •Faulty generator
P0563	System Voltage High	
P0650	Malfunction Indicator Lamp(MIL) Control Circuit Malfunction	<ul style="list-style-type: none"> •Open or short between lamp and ECM •Faulty lamp
P1134	O2 Sensor Circuit - Transition Switch Time Malfunction / Slope(Bank 1 / Sensor1)	<ul style="list-style-type: none"> •HO2S Deteriorated •Foreign Material Deposit

P1166	O2 Sensor System - Lambda Controller at the Limit (Bank 1)	<ul style="list-style-type: none"> •P1166 is case for HO2S (Bank 1, Sensor 1) Signal line open •Fuel system (Fuel tank/Pressure regulator/Fuel pump/PCSV) Failure •Poor connection to fuel line hose/Sealing/Cut •Sealing between purge valve and fuel tank •Air leakage in exhaust system •Ignition system (Ignition coil, spark plug, cable) failure •Surge tank and intake port failure
P1372	Segment Time Acquisition Incorrect	<ul style="list-style-type: none"> •Improperly installed target wheel •Faulty wires between ECM and wheel speed sensor •Bad signal of wheel speed sensor •Poor connection •Faulty CKP sensor
P1505	Idle Charge Actuator Signal Low of Coil #1	<ul style="list-style-type: none"> •Open or short to GND between ISC and ECM •Faulty ISC
P1506	Idle Charge Actuator Signal High of Coil #1	<ul style="list-style-type: none"> •Short to battery between ISC and ECM •Faulty ISC
P1507	Idle Charge Actuator Signal Low of Coil #2	<ul style="list-style-type: none"> •Open or short to GND between ISC and ECM •Faulty ISC
P1508	Idle Charge Actuator Signal High of Coil #2	<ul style="list-style-type: none"> •Short to battery between ISC and ECM •Faulty ISC
P1529	TCM Request for MIL On / Freeze Frame to ECM via CAN	<p>•This is only a request from TCM to turn the MIL ON. The fault code is stored in the TCM. The freeze frame data is stored in the ECM under the P1529 request code. Be sure to retrieve freeze frame data before clearing code P1529 from ECM.</p>