

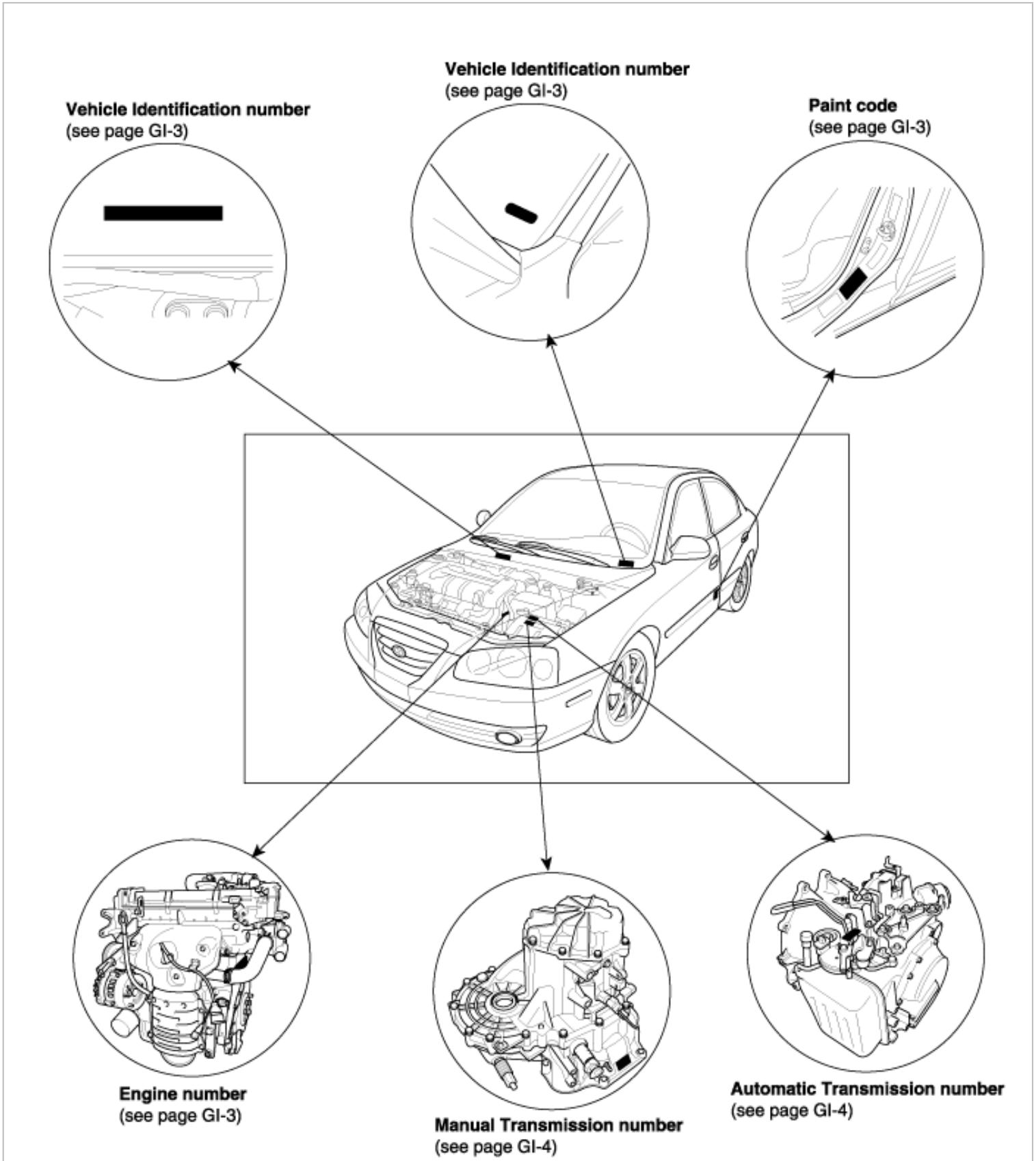

## IDENTIFICATION NUMBER LOCATIONS



## IDENTIFICATION NUMBER DESCRIPTION

## VEHICLE IDENTIFICATION NUMBER

<b>K</b>	<b>M</b>	<b>H</b>	<b>D</b>	<b>L</b>	<b>4</b>	<b>3</b>	<b>D</b>	<b>1</b>	<b>3</b>	<b>U</b>	<b>000001</b>
1	2	3	4	5	6	7	8	9	10	11	12

1. Geographic zone
  - K : Korea
2. Manufacturer
  - M : Hyundai motor company
3. Vehicle type
  - H : Passenger
4. Vehicle line
  - D : ELANTRA
5. Model & Series
  - L : STANDAD (L)
  - M : DELUXE (GL)
  - N: SUPER DELUXE (GLS)
6. Body type
  - 4 : Sedan 4-door
  - 5 : Sedan 5-door
7. Restraint system
  - 3 :Driver side - Active belt and air bag
  - 4 : Passenger side - Active belt or passive belt
  - 5 : Depowered - Air bag
8. Engine type
  - D : Gas 2.0 DOHC
9. Check digit
  - 0 ~ 9, X
10. Production year
  - 3 : 2003, 4 : 2004, 5 : 2005, 6 : 2006
11. Plant of production
  - U : Ulsan (korea)
12. Vehicle production sequence number
  - 000001 ~ 999999

### PAINT CODE

CODE	COLOR
NW	Noble White
EB	Ebony Black
LS	Smart color
OT	Special color
VX	Samba Red

YY	Sunny Yellow
TW	New Sliver
SK	Silver Sage
UE	Gold Savor
YO	Lime green
WN	Dark navy blue
AH	Amabile Rose
XX	Exciting Blue
UL	Ivy Gray
KO	Premie Beige

### ENGINE IDENTIFICATION NUMBER

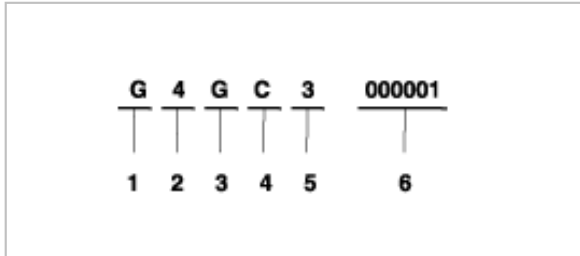

1. Engine fuel  
- G : Gasoline
2. Engine range  
- 4 : In line 4 cycle 4 cylinder
3. Engine development order  
- G :BETA Engine
4. Engine capacity  
- C : 1975cc
5. Production year  
- 3 : 2003, 4 : 2004, 5 : 2005, 6 : 2006
6. Engine production sequence number  
- : 000001 ~ 999999

### TRANSMISSION IDENTIFICATION NUMBER

#### MANUAL

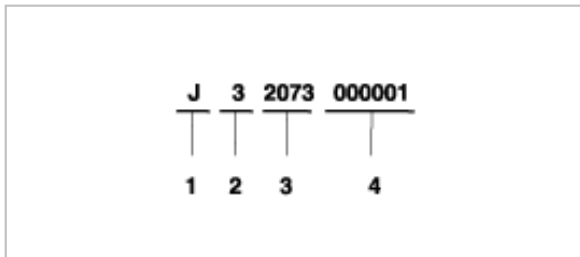

1. Model  
- J : M5BF2

**2. Production year**

- 2 : 2002, 3 : 2003, 4 : 2004
- 5 : 2005, 6 : 2006, 7 : 2007

**3. Gear ratio**

2073 : 3.650

**4. Transaxle production sequence number**

- 000001 ~ 999999

**AUTOMATIC**

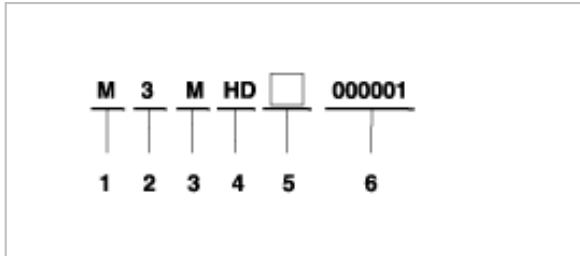

**1. Modle**

- M : F4A42

**2. Production year**

- 2 : 2002, 3 : 2003, 4 : 2004
- 5 : 2005, 6 : 2006, 7 : 2007

**3. Gear ratio**

M : 3.770

**4. Detailed chassification**

- HD : 2.0 DOHC

**5. Spare**

**6. Transaxle production sequence number**

- 000001 ~ 999999

**WARNING / CAUTION LABEL LOCATIONS**

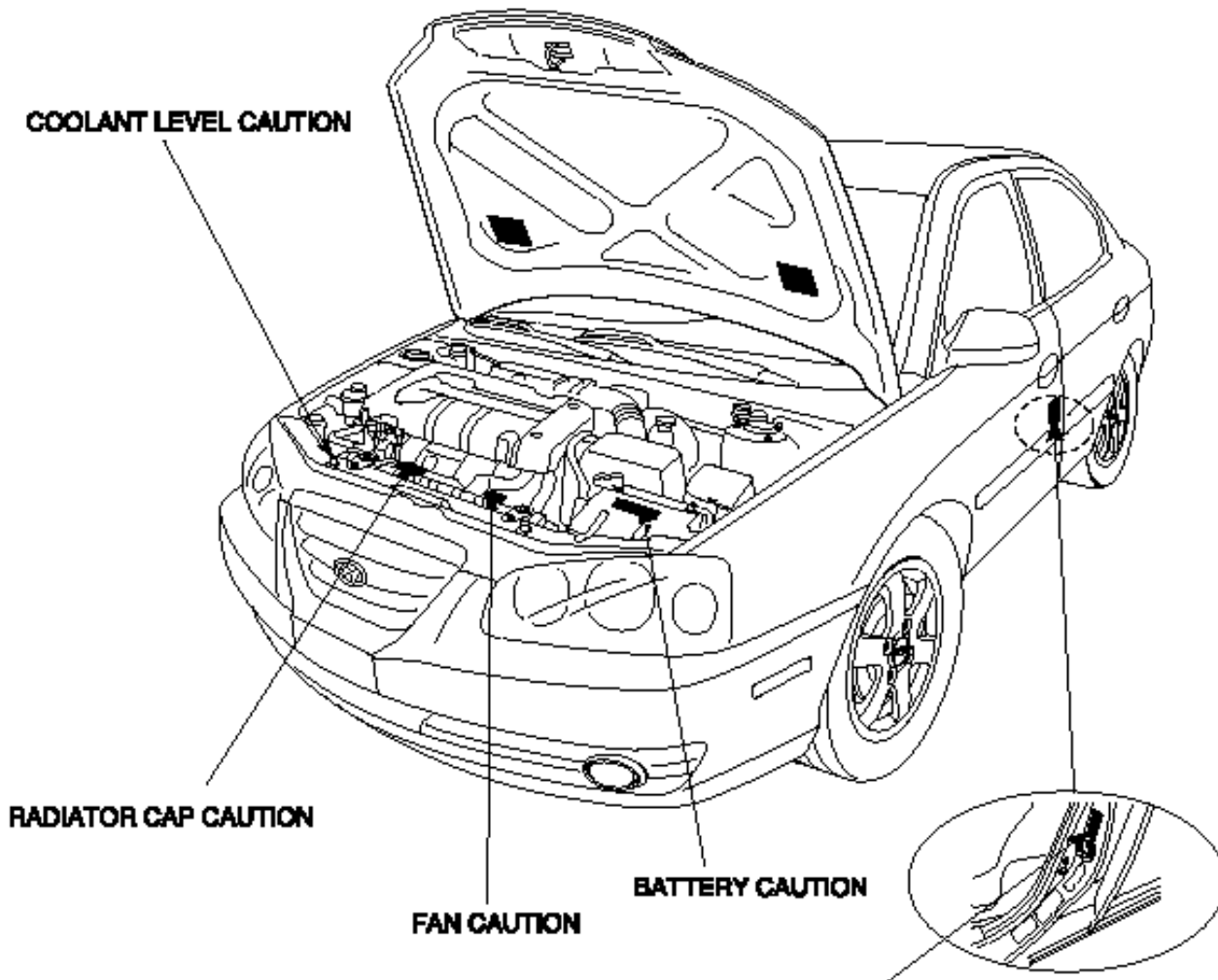

**SIDE AIRBAG INFORMATION**

**ATTENTION**

**SRS VEHICLE**

THIS CAR IS EQUIPPED WITH A SUPPLEMENTAL RESTRAINT SYSTEM. TO PROVIDE CONTINUED RELIABILITY, CERTAIN ELEMENTS OF THE SUPPLEMENTAL RESTRAINT SYSTEM SHALL BE SERVICED OR REPLACED BY AUTHORIZED DEALER TEN YEARS AFTER VEHICLE LABEL FOR FURTHER INFORMATION. SEE OWNER'S MANUAL.

**SIDE AIR BAG**

THIS CAR IS EQUIPPED WITH A SIDE AIRBAG SYSTEM. TO PROVIDE CONTINUED RELIABILITY, CERTAIN ELEMENTS OF THE SIDE AIRBAG SYSTEM SHALL BE SERVICED OR REPLACED BY AUTHORIZED DEALER TEN YEARS AFTER VEHICLE MANUFACTURE DATE SHOWN ON CERTIFICATION LABEL FOR FURTHER INFORMATION. SEE OWNER'S MANUAL.

**AIR BAG WARNING / CAUTION LABEL**

**CAUTION**

**AIRBAG : Handling is limited to trained personnel. To be used only in prescribed vehicles. If not properly installed, device may become a dangerous projectile. See service manual instruction**

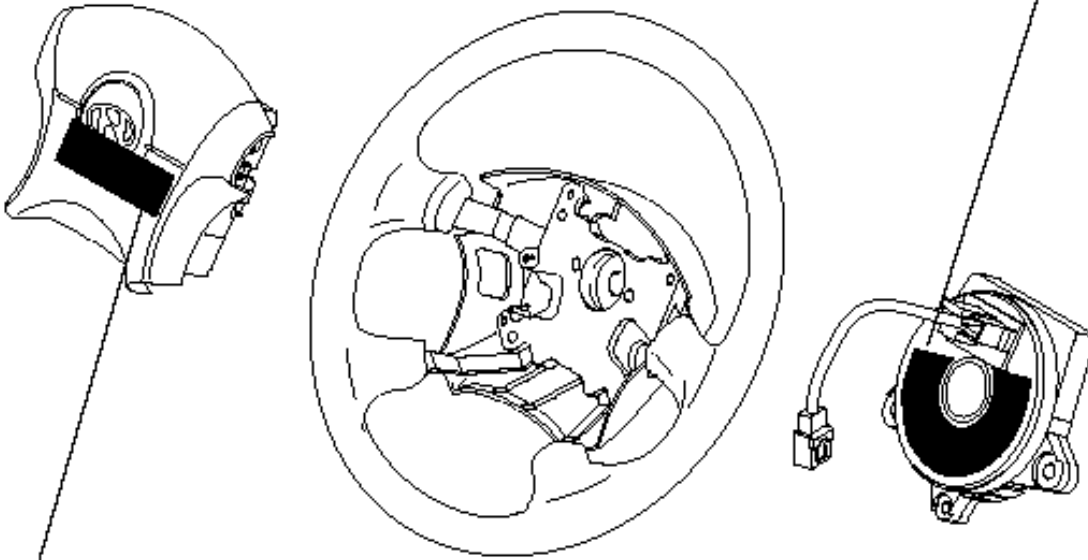

**DRIVE MODULE CAUTION**

**Caution**

**Don't open, remove or transfer to another vehicle. Risk of malfunction and bodily injury!**

**This unit is to be installed and/or dismantled by trained personnel only. This item contains an explosive to be installed igniter.**

**AIR BAG WARNING / CAUTION LABEL (CONT'D)**

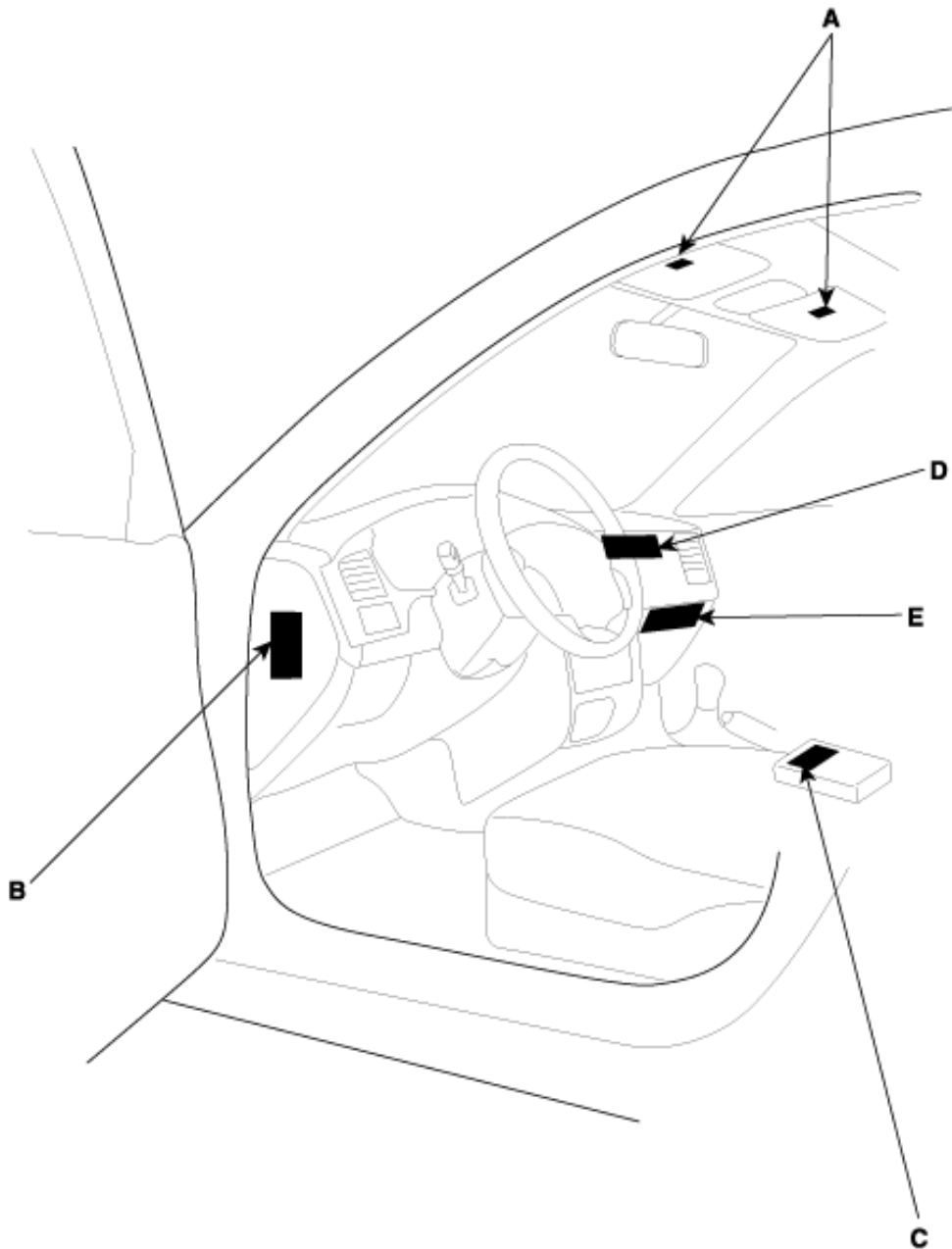

## WARNING / CAUTION LABEL (cont'd)

A : SRS INFORMATION

WARNING

Death or serious can occur.

- Children 12 and under can occur.
- The back seat is the safest place for children.
- Children 12 and under can be killed by the airbag.
- Never put a rear-facing child seat in the front.
- Sit as far back as possible from the airbag.
- Always use seat belts and child restraints.

**B : WARNING**

**SEE OWNER'S MANUAL.**

This car is equipped a side airbag for each front seat.

- Do not use any accessory seat covers.
- Use of other seat covers could reduce the effect of the system.
- Do not install any accessories on the side or near the side airbag.
- Do not use excessive force on the side of the seal.
- For further information, see the owner's manual.

**C : CAUTION**

**AIRBAG ESPE UNIT**

Detach connector before unmounting. Assemble strictly according to manual instructions.

**D : PASSENGER MODULE CAUTION**

**CAUTION**

Don't open, remove or transfer to another vehicle. Risk of malfunction and bodily injury!

This unit is to be installed and/or dismantled by trained personnel only. This item contains an explosive to be installed igniter.

**E : SUPPLEMENTAL RESTRAINT SYSTEM (AIRBAG) INFORMATION**

- The airbag is a Supplement Restraint System (SRS).  
You must always wear the seat belts.
- The airbag system condition is normal when the "SRS" lamp in the cluster flashes approximately 6 times after the ignition key is turned on and then goes off.
- If any of the following condition occur, the system must be serviced.
- "SRS" lamp does not light up when the key is turned on.
- "SRS" lamp stays lit or flashes continuously.
- The airbag has inflated.
- The airbag system must be inspected by an authorized dealer ten years after the vehicle manufacture date shown on the certification label, located on left front door opening area.

**WARNING**

Failure to the above instructions may result in injury to you or other occupants in the vehicle

- See the "SRS" section in Owner's Manual for more information about airbags.

**UNDER-HOOD EMISSION CONTROL LABEL**

**Emission Group Identification**

**Example :**





A :

CANADA

THIS VEHICLE CONFORMS TO CANADA AND U.S EPA REGULATIONS APPLICABLE TO 2004 MODEL YEAR NEW LEV PASSENGER CARS.

B :

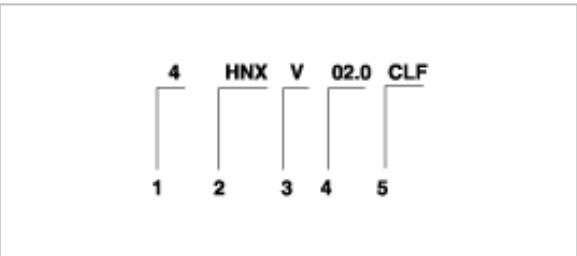

1. Model Year

- 4 : 2004

2. Manufacturer Subcode

- HNX : HYUNDAI MOTOR

3. Family Type

- V : Passenger car

4. Displacement

5. Sequence Characters.

C :

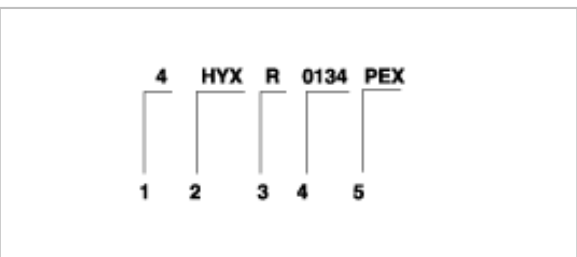

1. Model Year

- 4 : 2004

2. Manufacturer Subcode

- HYX : HYUNDAI MOTOR

### 3. Family Type

- R : EVAP/ORVR

### 4. Canister Work Capacity

### 5. Sequence Characters.

## LIFT AND SUPPORT POINTS

### WARNING

When heavy rear components such as suspension, fuel tank, spare tire, tailgate and trunk lid are to be removed, place additional weight in the luggage area before hoisting. When substantial weight is removed from the rear of the vehicle, the center of gravity may change and can cause the vehicle to tip forward on the hoist.

### NOTE

- Since each tire/wheel assembly weights approximately 30lbs (14kg), placing the front wheels in the luggage area can assist with the weight distribution.
- Use the same support points to support the vehicle on safely stands.

1. Place the lift blocks under the support points as shown in the illustration.
2. Raise the hoist a few inches (centimeters) and rock the vehicle to be sure it is firmly supported.
3. Raise the hoist to full height to inspect the lift points for secure support.

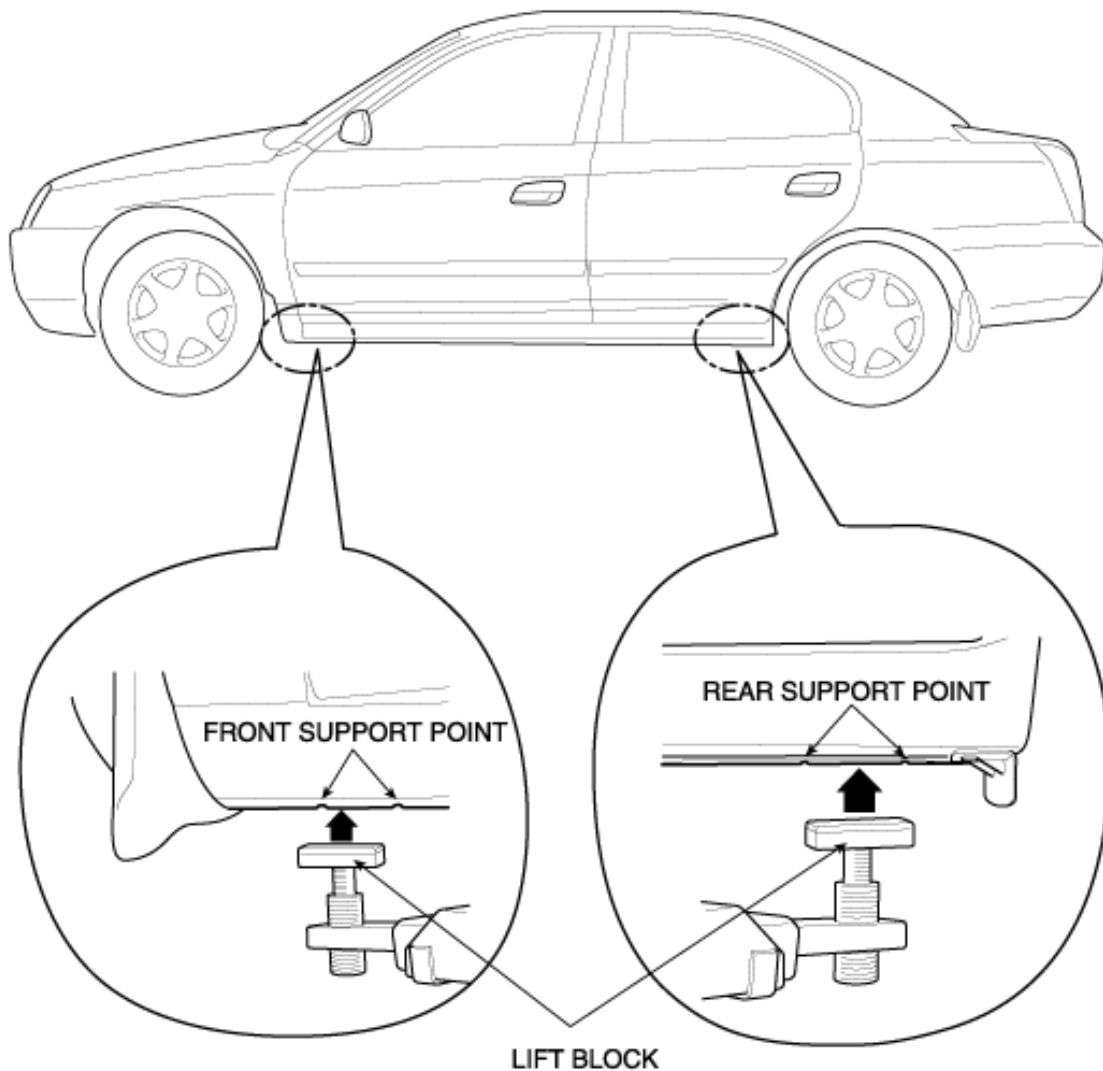

## TOWING

If the vehicle needs to be towed, call a professional towing service. Never tow vehicle with just a rope or chain. It is very dangerous.

If the vehicle cannot be transported by flat-bed, it should be towed with the front wheels off the ground. If due to damage, the vehicle must be towed with the front wheels on the ground, do not following :

Manual Transmission

- Release the parking brake.
- Shift the transmission to neutral

Automatic Transmission

- Release the parking brake.
- Start the engine.
- Shift to [D] position, then [N] position.
- Turn off the engine.

### CAUTION

- Improper towing preparation will damage the transmission. Follow the above procedure exactly. Follow the above procedure exactly. If you cannot shift the transmission or start the engine(automatic transmission), your vehicle must be transported on a flat-bed.
- It is best to tow vehicle no farther than 19miles (30km), and keep the speed below 30mph (50km/h).
- Trying to lift or tow your vehicle by the bumpers will cause serious damage. The bumpers are not designed to support the vehicle's weight.

### Front :

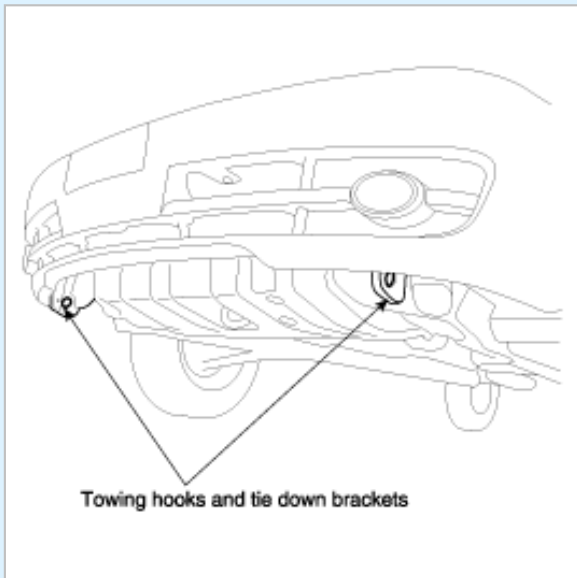

### Rear :

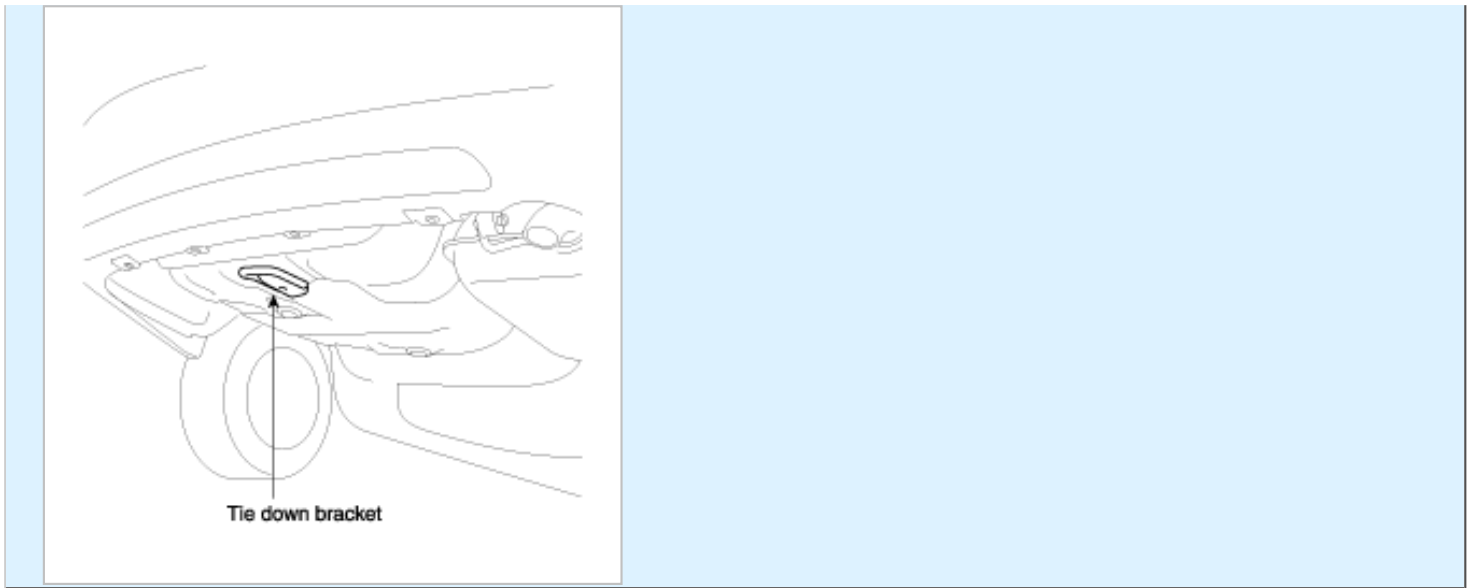

### TIGHTENING TORQUE TABLE OF STANDARD PARTS

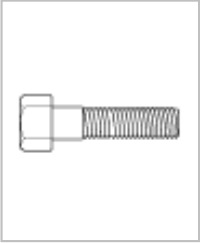
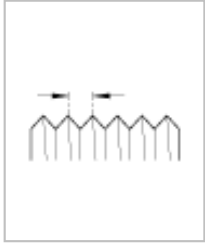
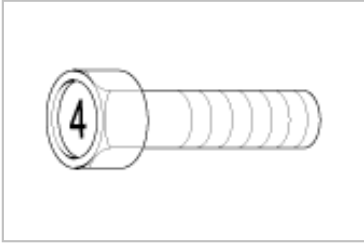
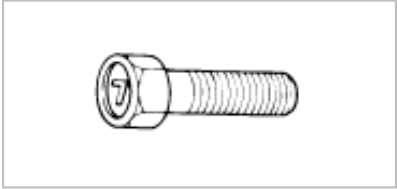
Bolt nominal diameter (mm)	Pitch (mm)	Torque Nm (kg.cm, lb.ft)	
		Head Mark 4	Head Mark 7
			
M5	0.8	3 ~ 4 (30 ~ 40, 2.2 ~ 2.9)	5 ~ 6 (50 ~ 60, 3.6 ~ 4.3)
M6	1.0	5 ~ 6 (50 ~ 50, 3.6 ~ 4.3)	9 ~ 11 (90 ~ 110, 6.5 ~ 8.0)
M8	1.25	12 ~ 15 (120 ~ 150, 9 ~ 11)	20 ~ 25 (200 ~ 250, 14.5 ~ 18.0)
M10	1.25	25 ~ 30 (250 ~ 300, 18 ~ 22)	30 ~ 50 (300 ~ 500, 22 ~ 36)
M12	1.25	35 ~ 45 (350 ~ 450, 25 ~ 33)	60 ~ 80 (600 ~ 800, 43 ~ 58)
M14	1.5	75 ~ 85 (750 ~ 850, 54 ~ 61)	120 ~ 140 (1,200 ~ 1,400, 85 ~ 100)
M16	1.5	110 ~ 130 (1,100 ~ 1,300, 80 ~ 94)	180 ~ 210 (1,800 ~ 2,100, 130 ~ 150)
M18	1.5	160 ~ 180 (1,600 ~ 1,800, 116 ~ 130)	260 ~ 300 (2,600 ~ 3,000, 190 ~ 215)
M20	1.5	220 ~ 250 (2,200 ~ 2,500, 160 ~ 180)	360 ~ 420 (3,600 ~ 4,200, 260 ~ 300)
M22	1.5	290 ~ 330 (2,900 ~ 3,300, 210 ~ 240)	480 ~ 550 (4,800 ~ 5,500, 350 ~ 400)

M24	1.5	360 ~ 420 (3,600 ~ 4,200, 260 ~ 300)	610 ~ 700 (6,100 ~ 7,000, 440 ~ 505)
-----	-----	--------------------------------------	--------------------------------------

**NOTE**

1. The torques shown in the table are standard values under the following conditions :
  - Nuts and bolts are made of galvanized steel bar.
  - Galvanized plain steel washers are inserted.
  - All nuts, bolts and plain washers are dry.
2. The torques shown in the table are not applicable :
  - When spring washers, toothed washers and the like are inserted.
  - If plastic parts are fastened.
  - If self-tapping screws or self-locking nuts are used.
  - If threads and surfaces are coated with oil.
3. If you reduce the torques in the table to the percentage indicated below, under the following conditions, it will be the standard value.
  - If spring washers are used : 85%
  - If threads and bearing surfaces are stained with oil : 85%

**LUBRICANTS**

**SELECTION OF ENGINE OIL**

Recommended API classification : SG OR SH ABOVE

**Recommended SAE viscosity grades :**

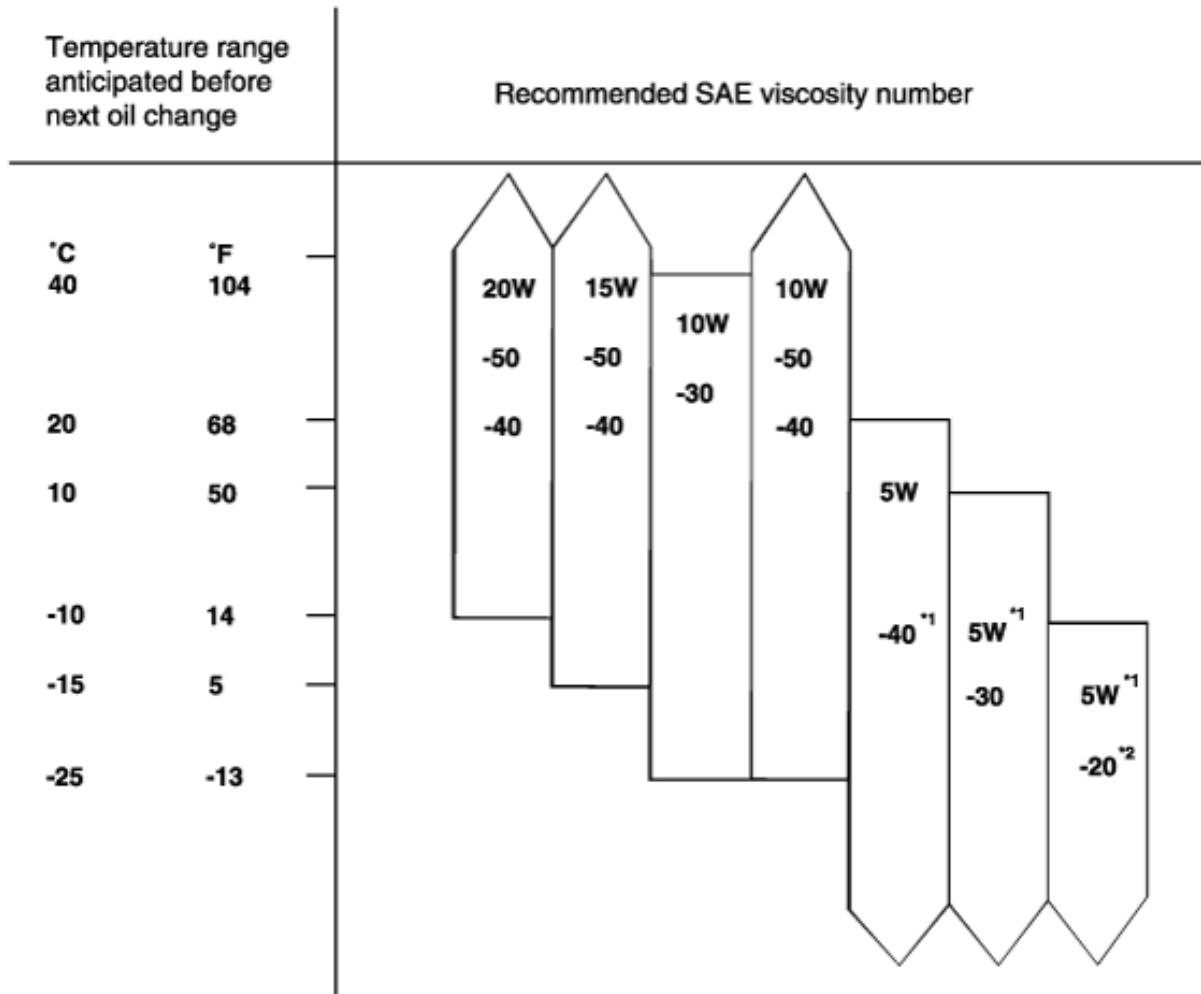

**\*1 Restricted by driving condition and environment.**  
**\*2 Not recommended for sustained high speed vehicle operation**

**NOTE**

For best performance and maximum protection of all types of operation, select only those lubricants which :

1. Satisfy the requirements of the API classification.
2. Have the proper SAE grade number for expected ambient temperature range.

Lubricants which do not have both an SAE grade number and an API service classification on the container should not be used.

**GENERAL SERVICE INFORMATION**

**PROTECTION OF THE VEHICLE**

Always be sure to cover fenders, seats, and floor areas before starting work.

**CAUTION**

The support rod must be inserted into the hole near the edge of the hood whenever you inspect the engine compartment to prevent the hood from falling and possibly causing injury.

Make sure that the support rod has been released prior to closing the hood. Always check to be sure the hood is firmly latched before driving the vehicle.

## PREPARATION OF TOOLS AND MEASURING EQUIPMENT

Be sure that all necessary tools and measuring equipment are available before starting work.

### SPECIAL TOOLS

Use special tools when they are required.

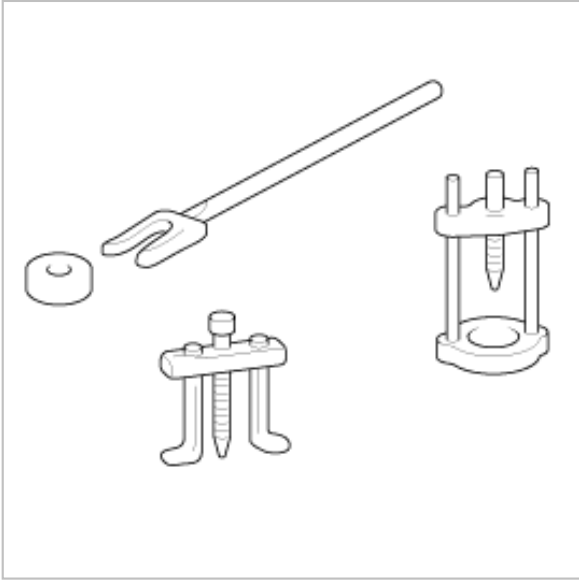

### REMOVAL OF PARTS

First find the cause of the problem and then determine whether removal or disassembly before starting the job.

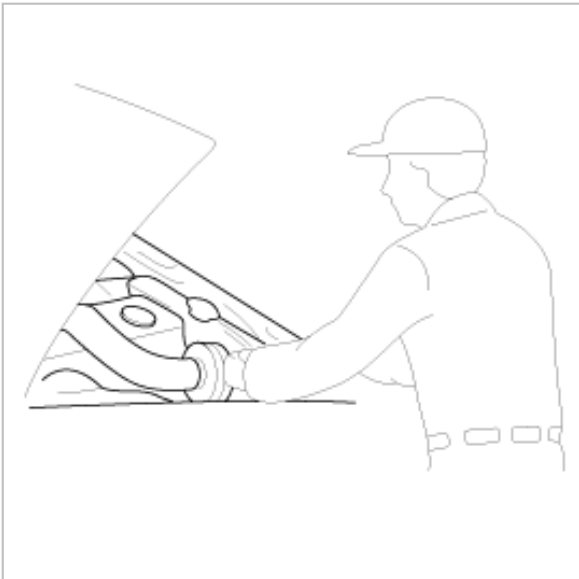

### DISASSEMBLY

If the disassembly procedure is complex, requiring many parts to be disassembled, all parts should be disassembled in a way that will not affect their performance or external appearance.

### 1. Inspection of parts

Each part, when removed, should be carefully inspected for malfunction, deformation, damage, and other problems.



### 2. Arrangement of parts

All disassembled parts should be carefully arranged for effective reassembly.

Be sure to separate and correctly identify the parts to be replaced from those that will be used again.



### 3. Cleaning parts for reuse

All parts to be used again should be carefully and thoroughly cleaned by an appropriate method.





## PARTS

When replacing parts, use HYUNDAI genuine parts.



## REPLACEMENT

Standard values, such as torques and certain adjustments, must be strictly observed in the reassembly of all parts.

If removed, the following parts should always be replaced with new ones.

1. Oil seals
2. Gaskets
3. O-rings
4. Lock washers
5. Cotter pins (split pins)

## 6. Plastic nuts

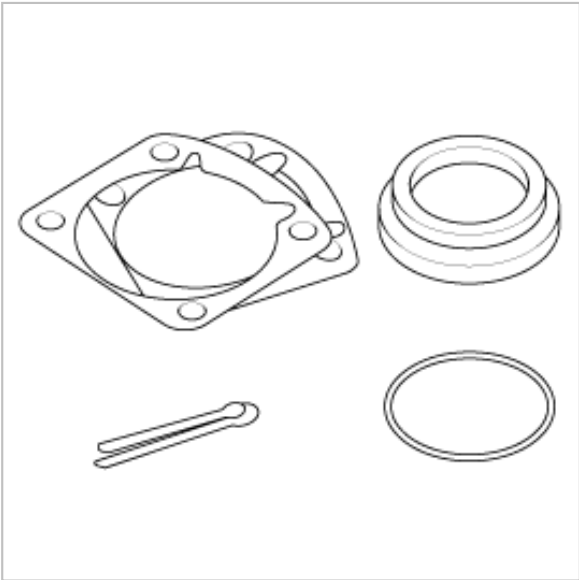

Depending on their location.

7. Selalant should be applied to gaskets.

8. Oil should be applied to the moving components of parts.

9. Specified oil or grease should be applied to the prescribed locations (oil seals, etc.) before assembly.

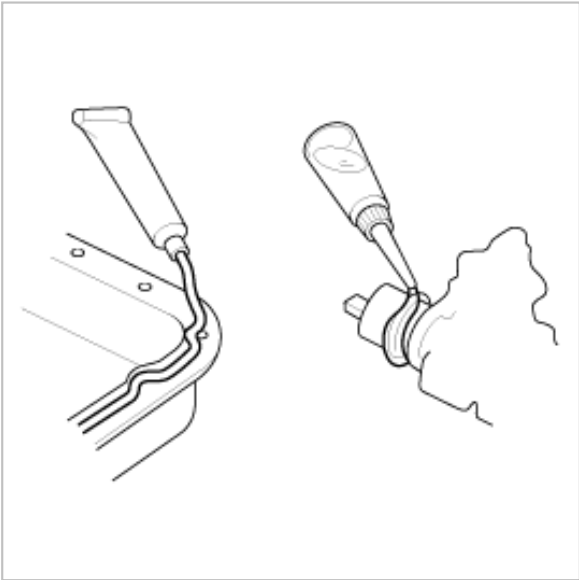

## ADJUSTMENT

Use gauges and testers to correctly adjust the parts to standard values.

## ELECTRICAL SYSTEM

1. Be sure to disconnect the battery cable from the negative (-) terminal of the battery.
2. Never pull on the wires when disconnecting connectors.
3. Locking connectors will click when the connector is secure.

4. Handle sensors and relays carefully. Be careful not to drop them against other parts.

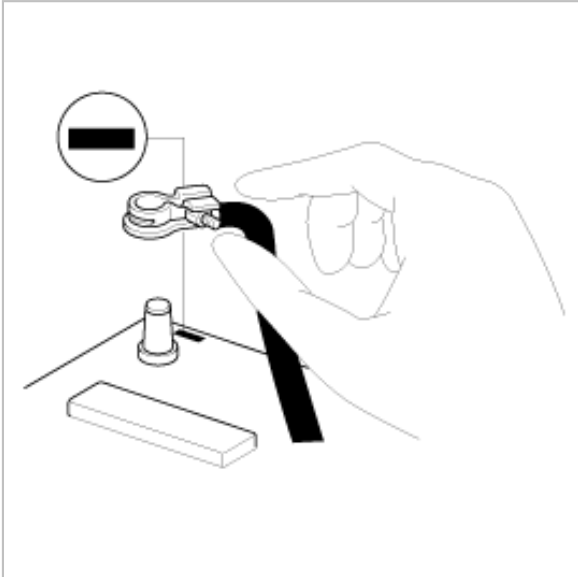

### **RUBBER PARTS AND TUBES**

Always prevent gasoline or from touching rubber parts or tubing.

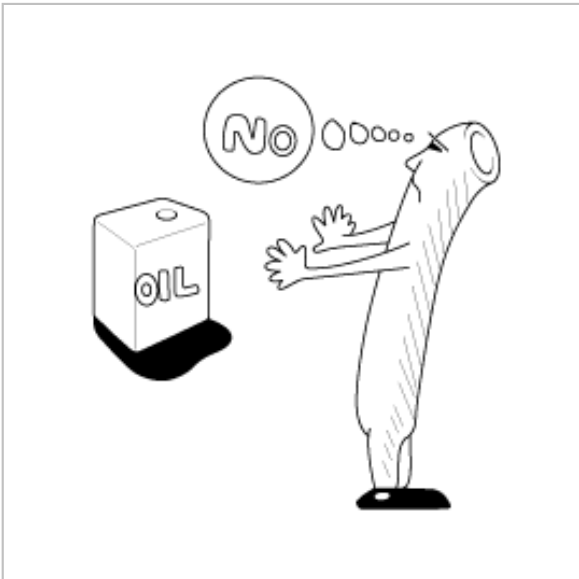

### **MEASURING BODY DIMENSIONS**

1. Basically, all measurements in this manual are taken with a tracking gauge.
2. When a measuring tape is used, check to be sure there is no elongation, twisting or bending.
3. For measuring dimensions, both projected dimensioners and actual - measurement dimensions are used in this manual.

### **PROJECTED DIMENSIONS**

1. These are the dimensions measured when the measurement points are projected from the vehicle's surface, and are the reference dimensions used for used for body alterations.

2. If the length of the tracking gauge ptobes is adjustable, measure it by lengthening one of two probes as long as the difference value in height of the two surface.

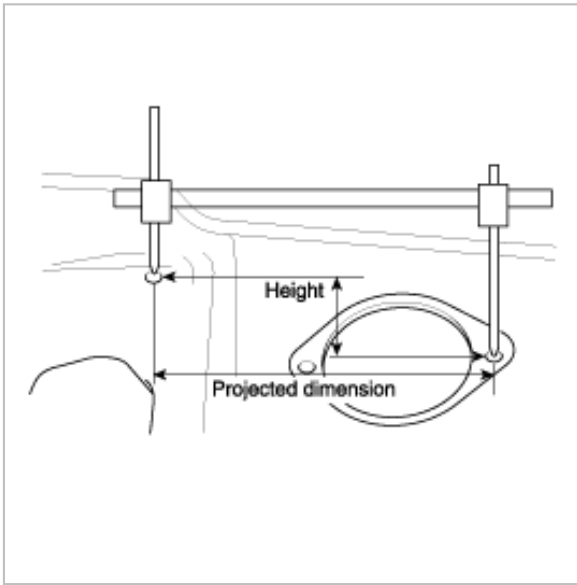

## MEASURING ACTUAL DIMENSIONS

1. These dimensions indicate the actual linear distance between mesasurement points, and are used as the reference dimensions when a tracking gauge is used for measurement.
2. First adjust both probes to the same length ( $A=A'$ ) before measurement.

### NOTE

Check the probes and gauge itself to make sure there is no free play.

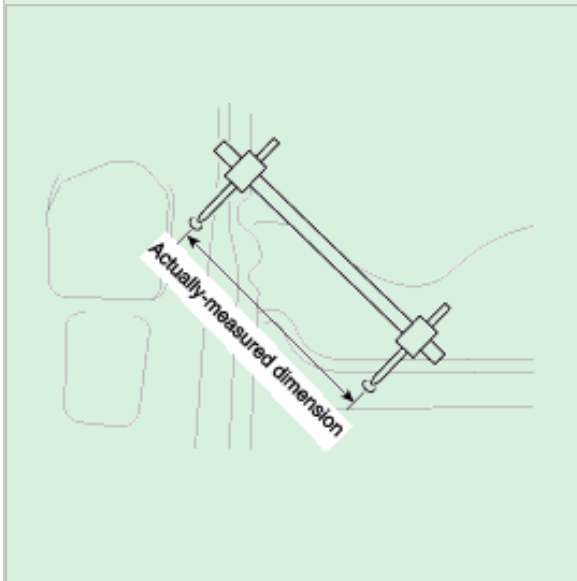

## MEASUREMENT POINT

Measurements should be taken at the center of the hole.

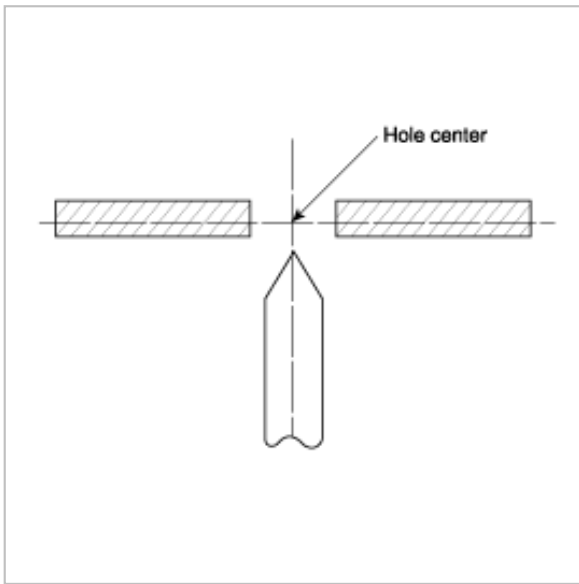

## CHECKING CABLES AND WIRES

1. Check the terminal for tightness.
2. Check terminals and wires for corrosion from battery electrolyte, etc.
3. Check terminals and wires for open circuits.
4. Check wire insulation and coating for damage, cracks and degrading.
5. Check the conductive parts of terminals for contact with other metallic parts (vehicle body and other parts).
6. Check grounded parts to verify that there is complete continuity between their attaching bolt(s) and the vehicle's body.
7. Check for incorrect wiring.
8. Check that the wiring is clamped to prevent contact with sharp corners of the vehicle body or hot parts (exhaust manifold, etc.)
9. Check that the wiring is clamped firmly to provide enough clearance from the fan pulley, fan belt and other rotating or moving parts.
10. Check that the wiring has a little space so that it can vibrate between fixed and moving parts such as the vehicle body and the engine.

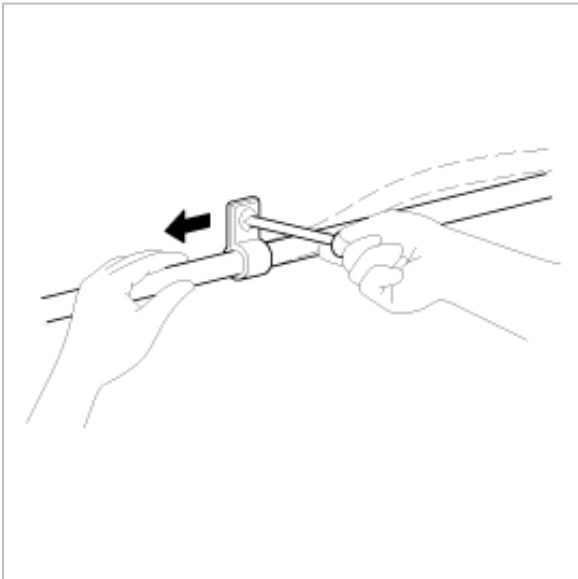

## CHECK FUSES

A blade type fuse test leads provided to allow checking the fuse itself without removing it from the fuse box. The fuse is good if the test lamp lights up when one lead is connected to the test leads (one at a time) and the other lead is grounded. (Turn on the ignition switch so that the fuse circuit becomes operative)

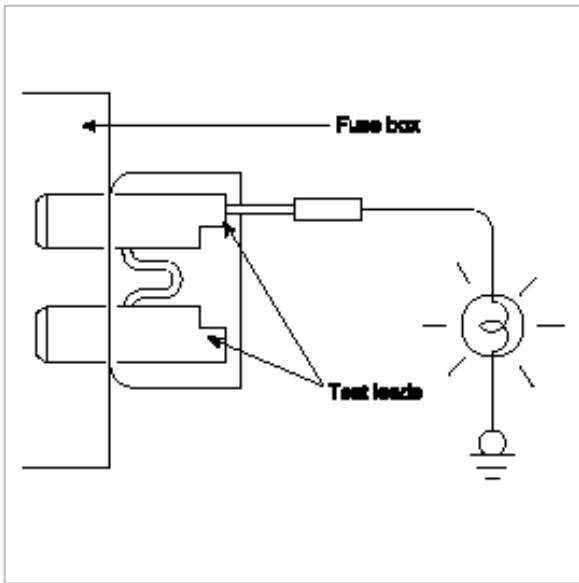

## SERVICING THE ELECTRICAL SYSTEM

1. Prior to servicing the electrical system, be sure to turn off the ignition switch and disconnect the battery ground cable.

### NOTE

In the course of MFI or ELC system diagnosis, when the battery cable is removed, any diagnostic trouble code retained by the computer will be cleared. Therefore, if necessary, read the diagnostic before removing the battery cable.

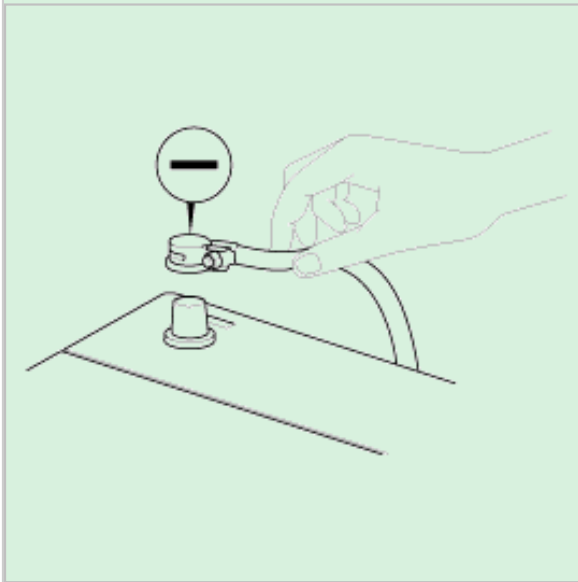

2. Attach the wiring harnesses with clamps so that there is no slack. However, for any harness which passes the engine or other vibrating parts of the vehicle, allow some slack within a range that does not allow the engine vibrations to cause the harness to come into contact with any of the surrounding parts and then secure the harness by using a clamp.

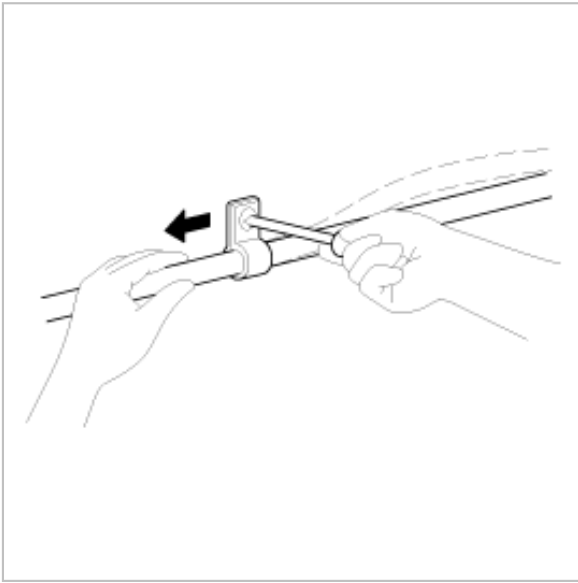

3. If any section of a wiring harness interferes with the edge of a parts, or a corner, wrap the section of the harness with tape or something similar in order to protect if from damage.

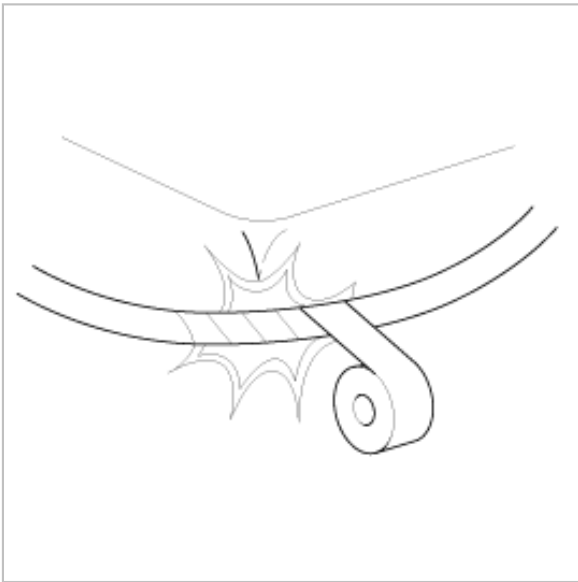

4. When installing any parts, be careful not to pinch or damage any of the wiring harness.

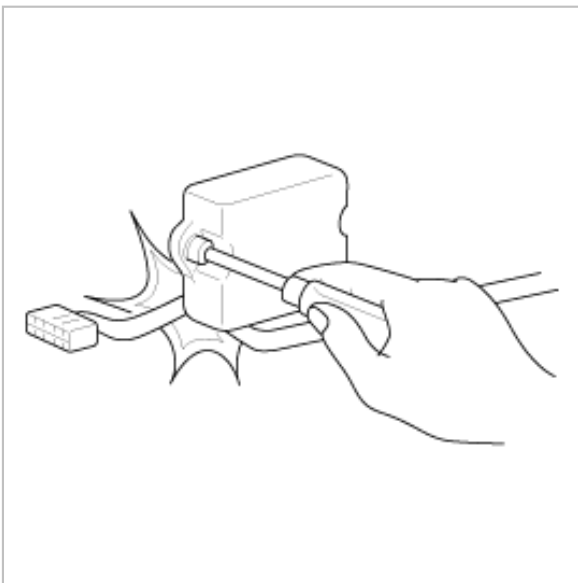

5. Never throw relays, sensors or electrical parts, or expose them to strong shock.

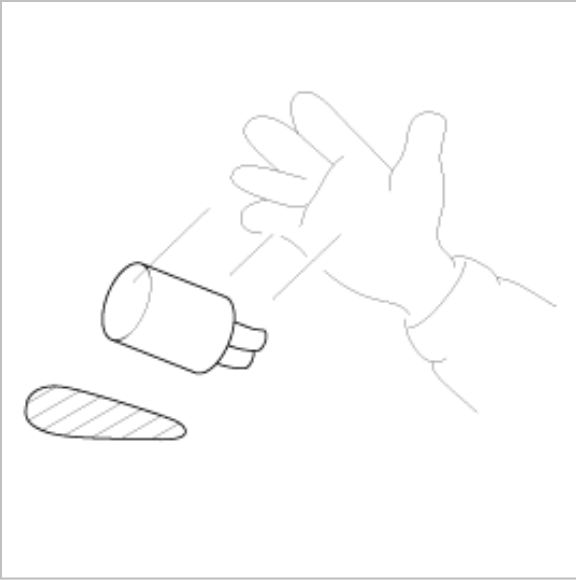

6. The electronic parts used in the computer, relays, etc. are readily damaged by heat. If there is a need for service operations that may cause the temperature to exceed 80°C (176°F), remove the electronic parts before hand.

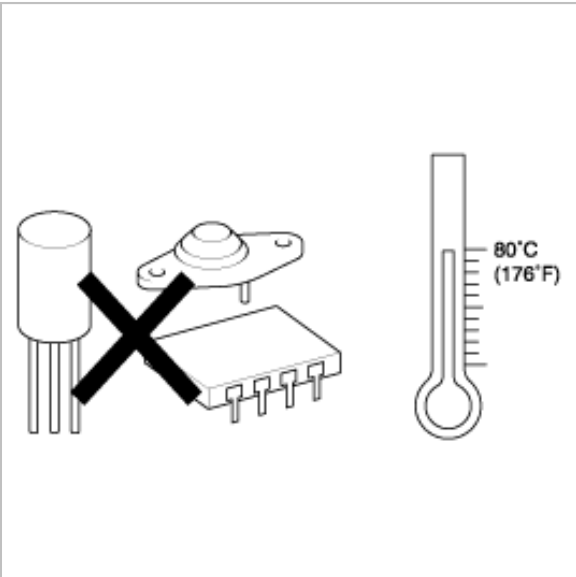

7. Loose connectors cause problems. Make sure that the connectors are always securely fastened.





8. When disconnecting a connector, be sure to grip only the connector, not the wires.

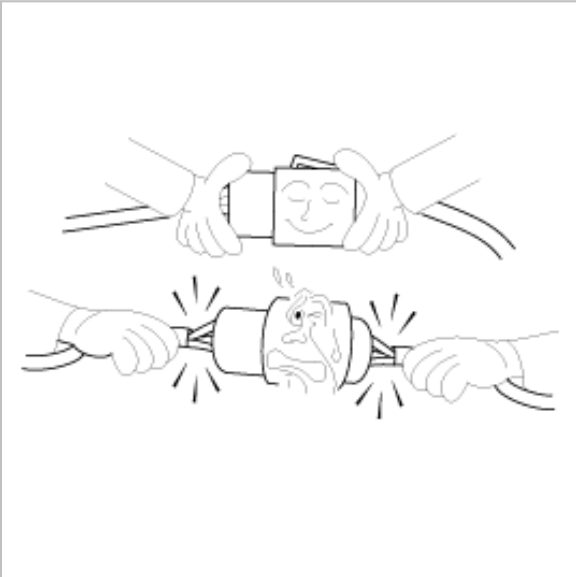

9. Disconnect connector which have catches by pressing in the direction of the arrows shown in the illustration.

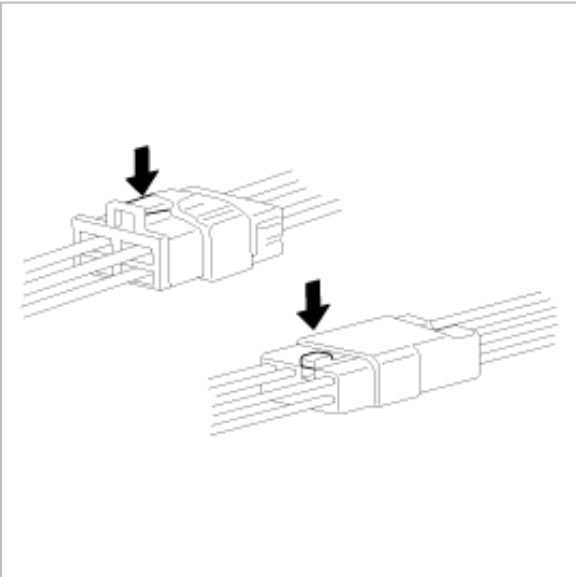

10. Connect connectors which have catches by inserting the connectors until they make a clicking sound.

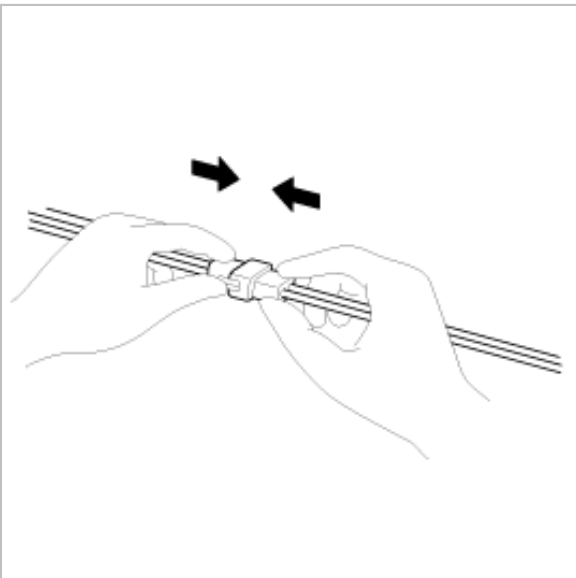

- When using a circuit tester to check continuity or voltage on connector terminals, insert the test probe into the harness side. If the connector is a sealed connector, insert the test probe through the hole in the rubber cap until contacts the terminal, being careful not to damage the insulation of the wires.

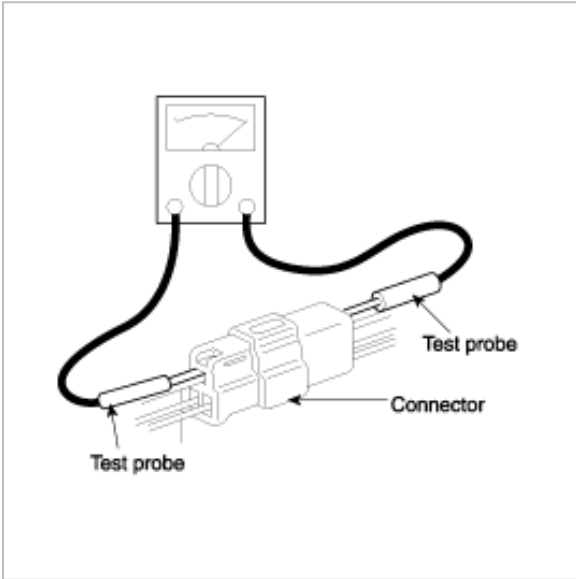

- To avoid overloading the wiring, take the electrical current load of the optional equipment into consideration, and determine the appropriate wire size.

Nominal size	SAE gauge No.	Permissible current	
		In engine compartment	Other areas
0.3mm <sup>2</sup>	AWG 22	-	5A
0.5mm <sup>2</sup>	AWG 20	7A	13A
0.85mm <sup>2</sup>	AWG 18	9A	17A
1.25mm <sup>2</sup>	AWG 16	12A	22A
2.0mm <sup>2</sup>	AWG 14	16A	30A
3.0mm <sup>2</sup>	AWG 12	21A	40A
5.0mm <sup>2</sup>	AWG 10	31A	54A

## PRECAUTIONS FOR CATALYTIC CONVERTER

### CAUTION

If a large amount of unburned gasoline flows into the converter, it may overheat and create a fire hazard. To prevent this observe the following precautions and explain them to your customer.

- Use only unleaded gasoline.
- Do not run the engine while the car is at rest for a long time. Avoid running the engine at fast idle for more than 10 minutes and idle speed for more than 20 minutes.
- Avoid start-jump tests. Do start-jumps only when absolutely necessary. Perform this test as rapidly as possible and, while testing, never race the engine.
- Do not measure engine compression for an extended time. Engine compression tests must be made as rapidly as possible.
- Avoid coasting with the ignition turned and during prolonged braking.

6. Do not dispose of used catalytic converter together with parts contaminated with gasoline or oil.

## BODY - DIMENSION

### 4 - DOOR

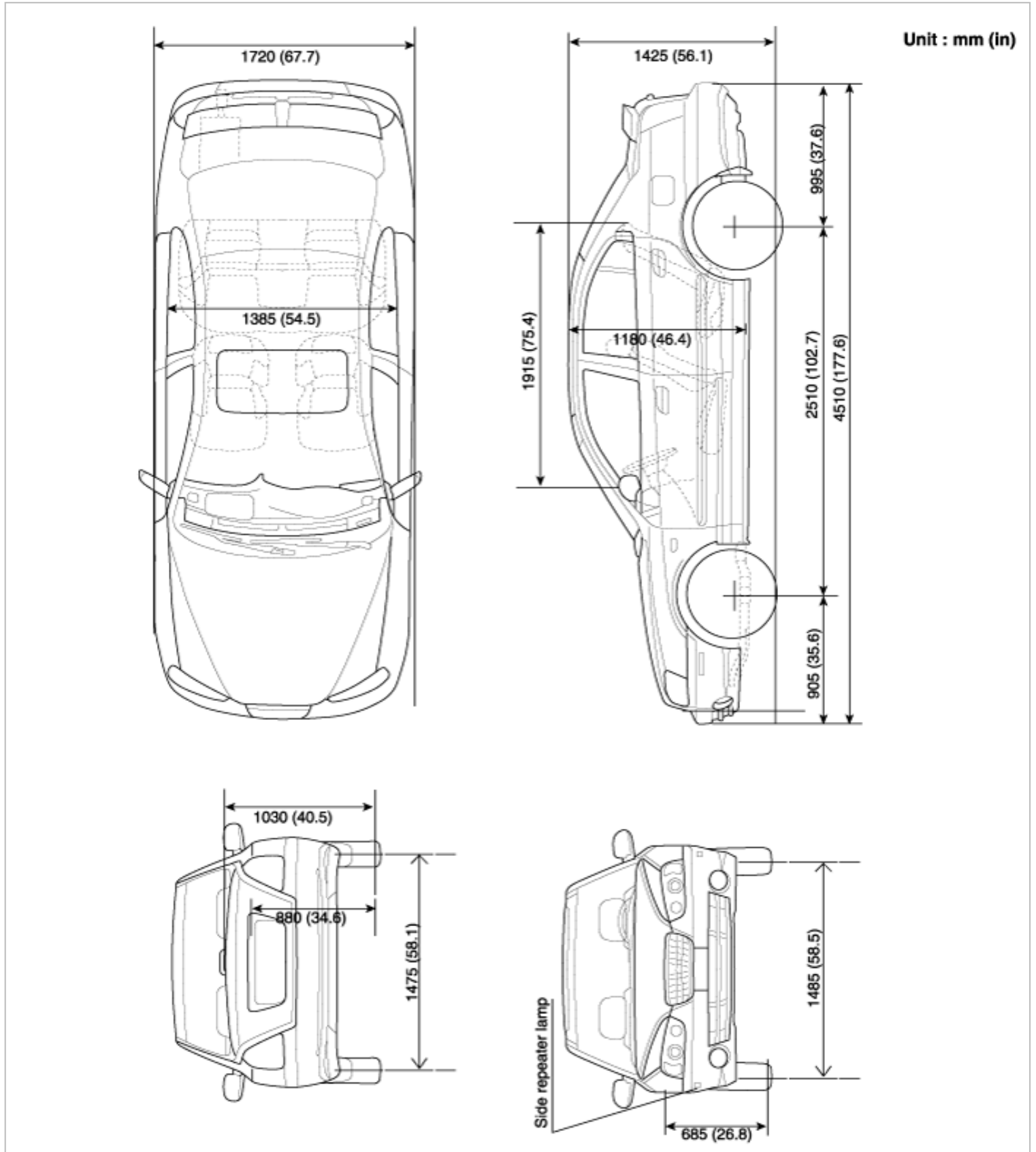

### 5 - DOOR

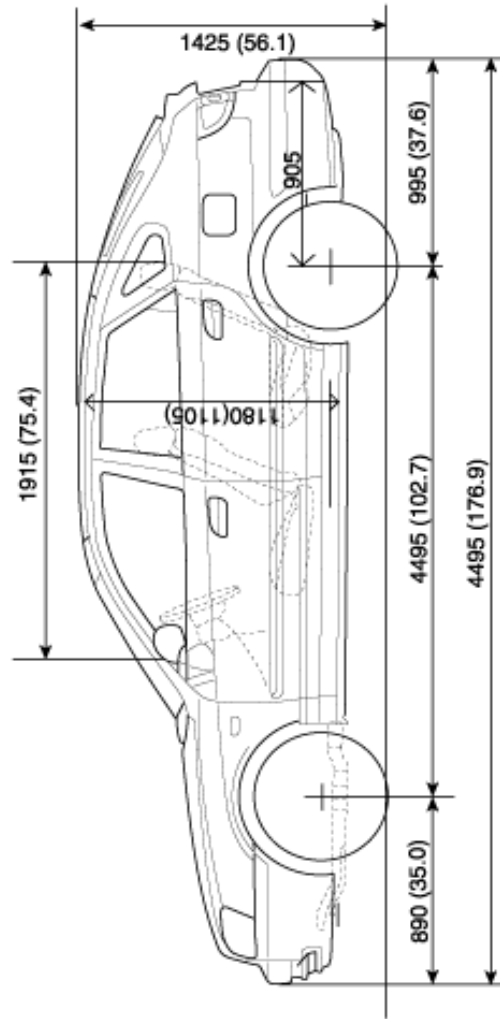
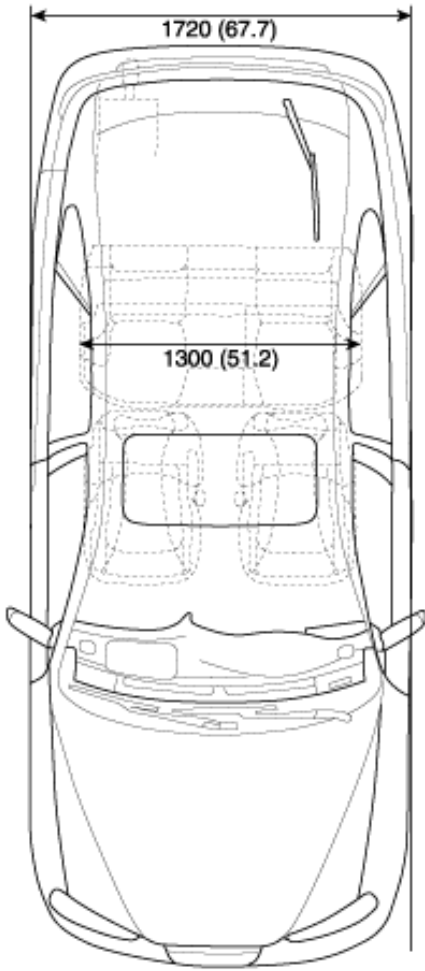

Unit : mm (in)

