



HYUNDAI

Elantra



Workshop Manual
2001 - 2006

COMPONENTS

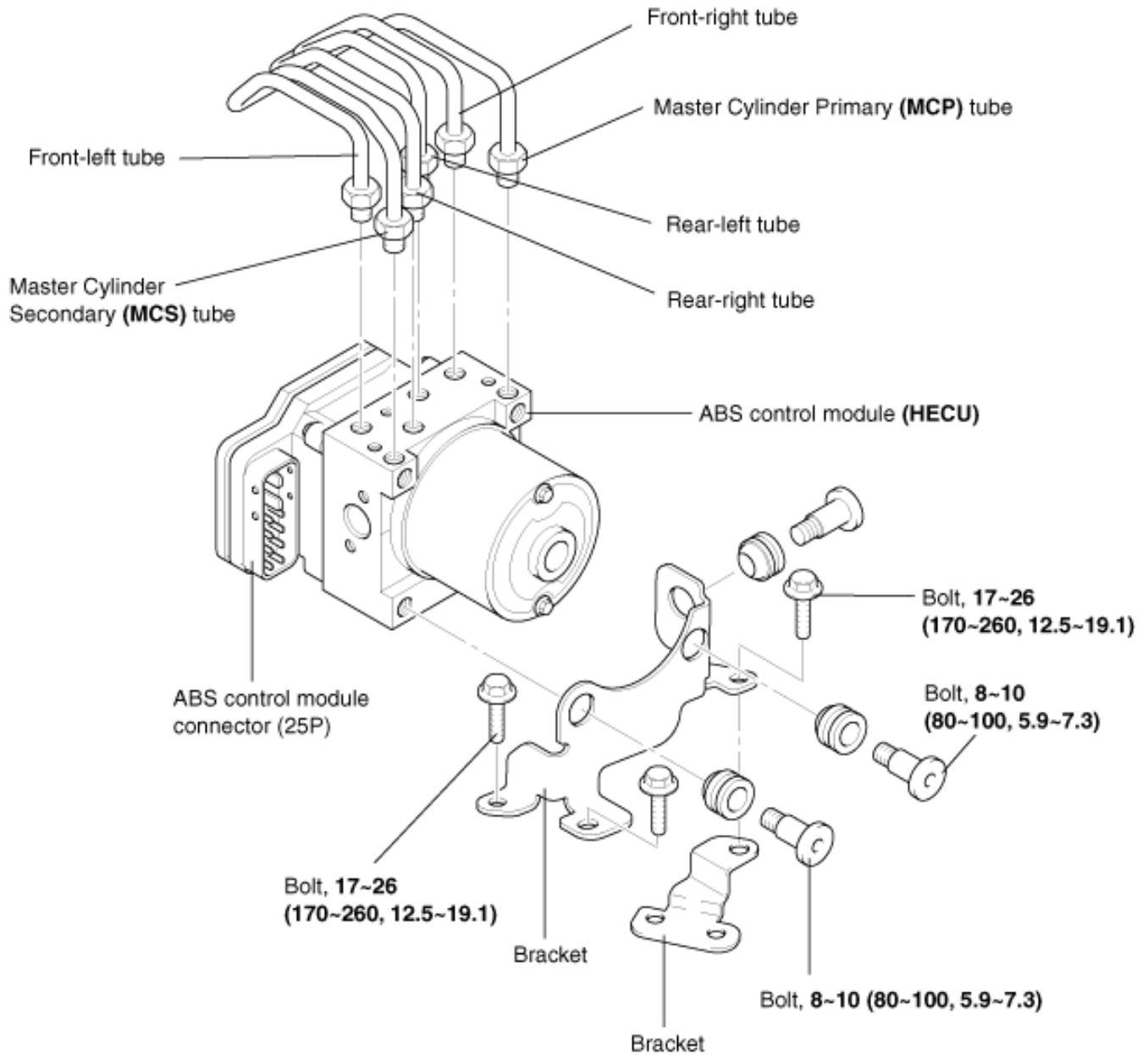

TORQUE: Nm (kg-cm, lb-ft)

REMOVAL

1. Disconnect the double lock connector (A) from the HECU.

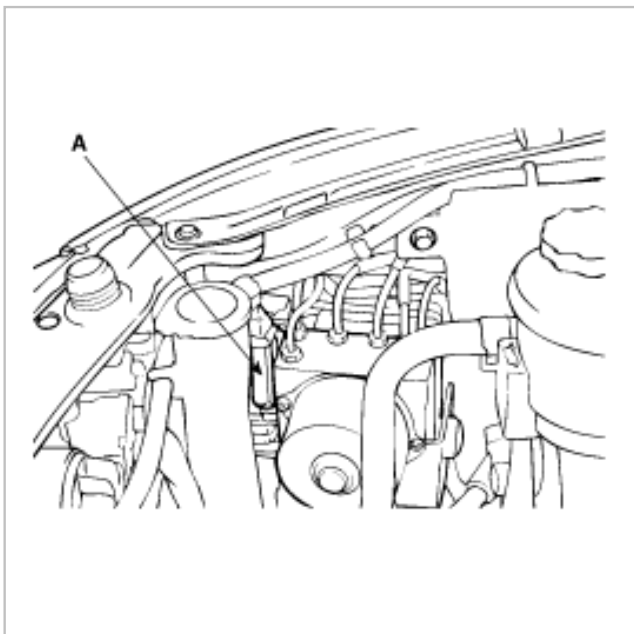

2. Disconnect the brake tubes from the HECU.



NOTE

- Do not spill brake fluid on the vehicle; it may damage the paint; if brake fluid gets on the paint, wash it off immediately with water.
- Take care not to damage or deform the brake lines during removal and installation.
- To prevent the brake fluid from flowing, plug and cover the hose ends and joints with a shop towel or equivalent material.

3. Remove the HECU bracket mounting bolt and remove the HECU.
Ebay User ID: reveleus1

CAUTION

1. Never attempt to disassemble the HECU.
2. The HECU must be transported and stored in an upright position and with the ports sealed. The HECU must not be drained.

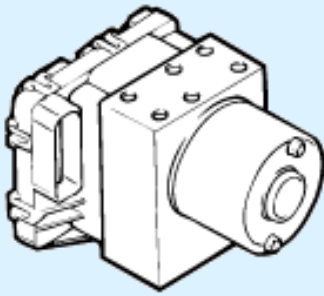

INSTALLATION

1. Installation is the reverse of removal.
2. Tighten the HECU mounting bolts and brake tube nuts to the specified torque.

Tightening torque

HECU mounting bolt:

8~10 Nm (80~100 kg·cm, 5.9~7.3 lb·ft)

HECU bracket mounting bolt:

17~26 Nm (170~260 kg·cm, 12.5~19.1 lb·ft)

Brake tube nut:

13~17 Nm (130~170 kg·cm, 9.5~12.5 lb·ft)

ABS OPERATION CHECK

WHEEL SPEED SENSOR OUTPUT VOLTAGE CHECK

1. Raise the vehicle and release the parking brake.
2. Disconnect the HECU harness connector's and measure from the harness side connector.

CAUTION

Be sure to remove the connector's double lock and insert the probe into the harness side (back-probe). Inserting it into the terminal side may result in a bad connection.

3. Rotate the wheel to be measured approximately 1/2 to 1 rotation per second, and check the output voltage using a circuit tester or an oscilloscope.

Ebay User ID: reveleus1

Wheel speed sensor	Front left	Front right	Rear left	Rear right
Terminal	1	19	5	22
	2	20	6	23

Output voltage:

When measuring with an oscilloscope :

130mV p-p or more

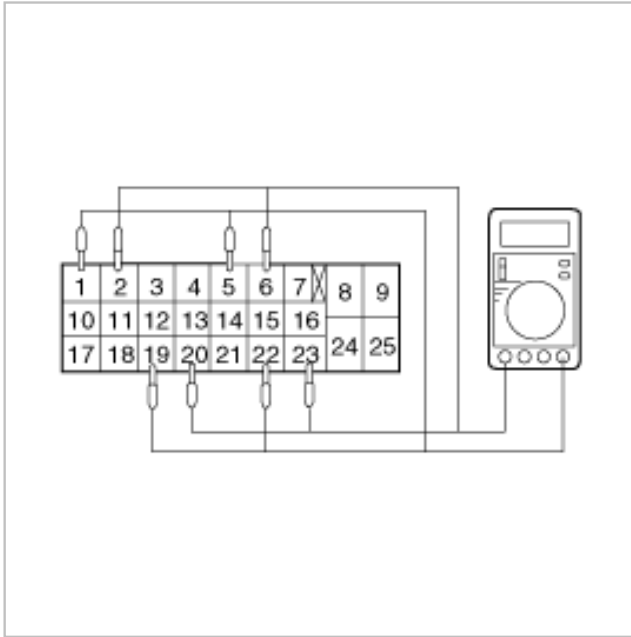



CIRCUIT DIAGRAM

[ABS]

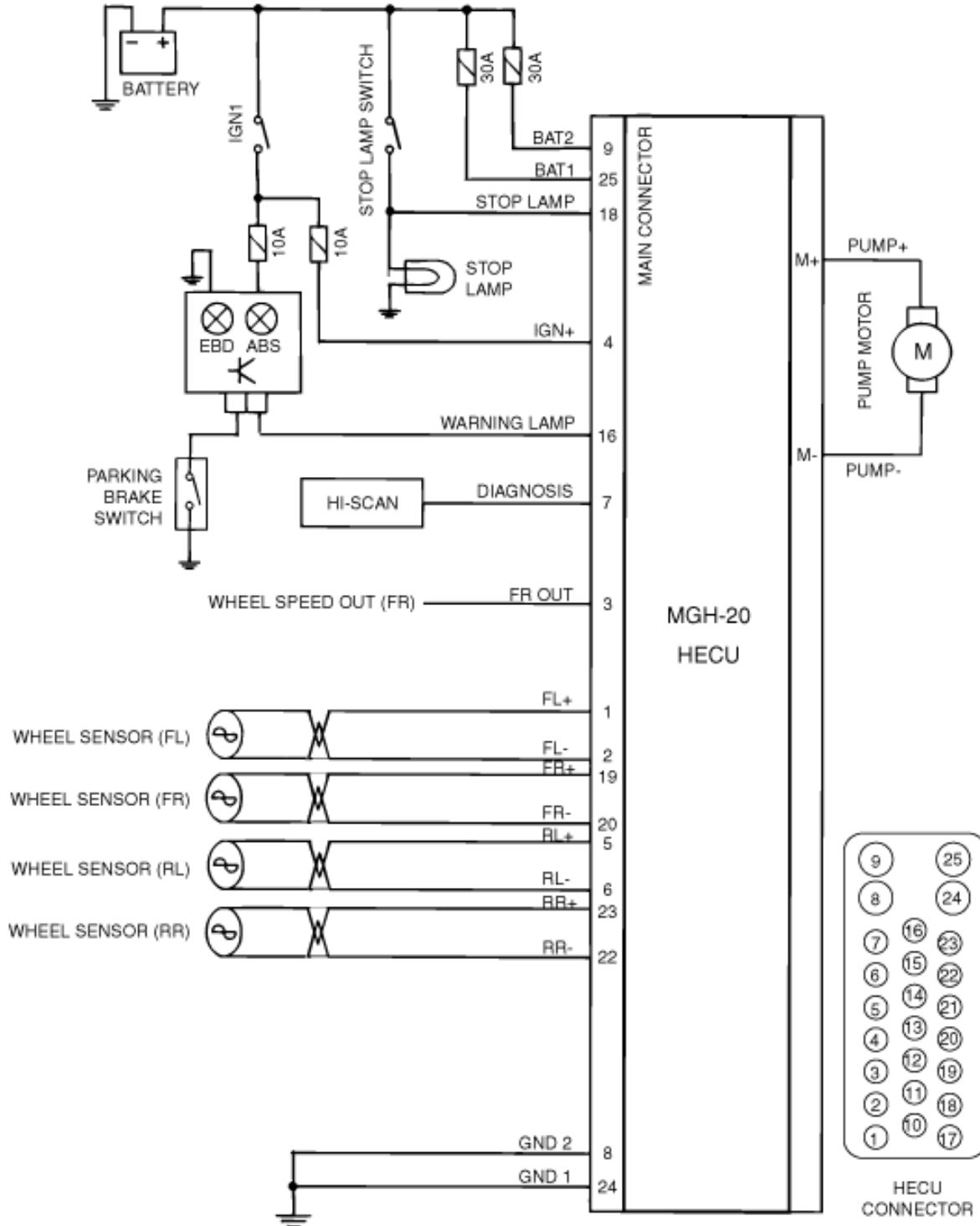

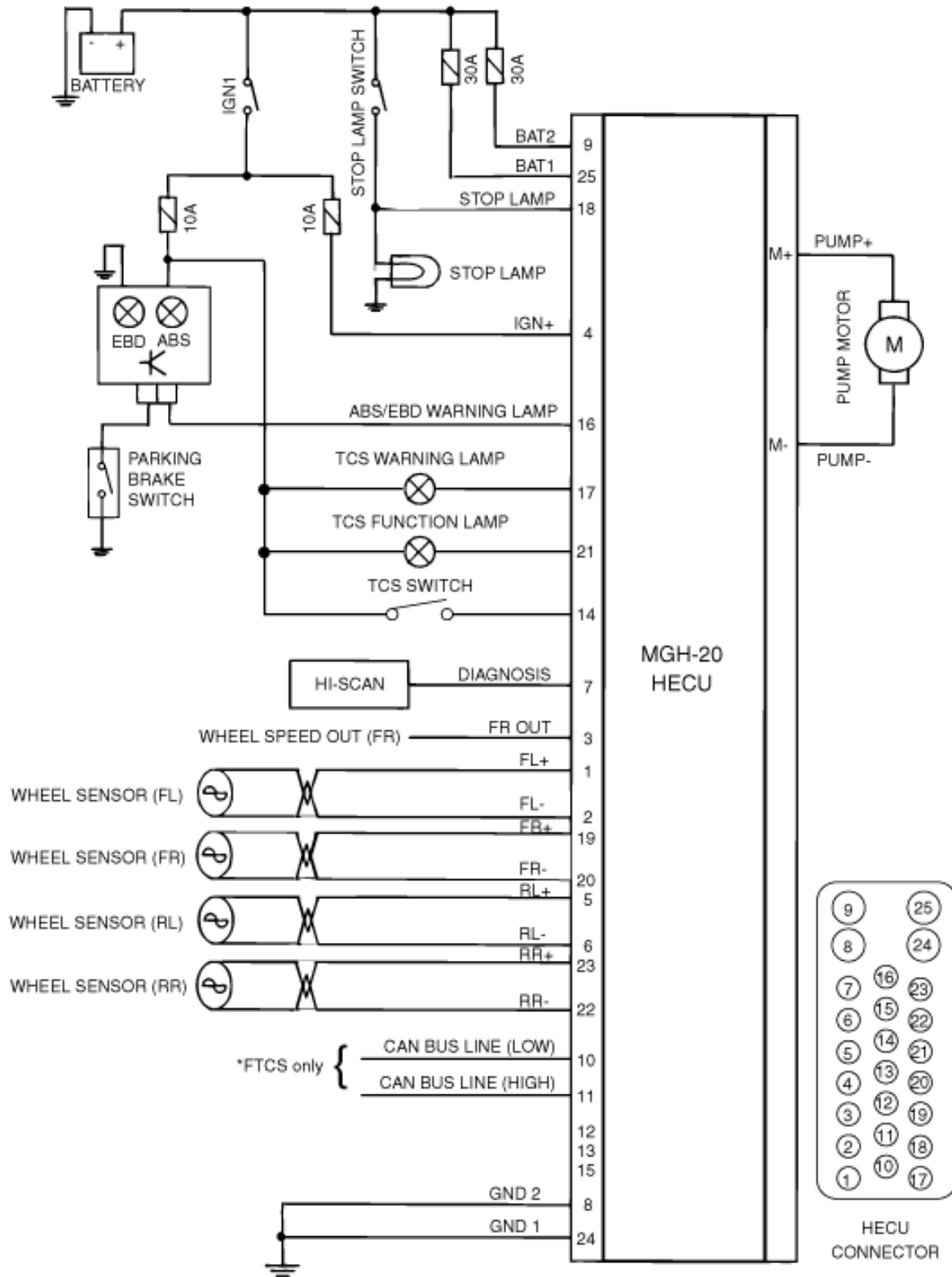

NOTE)

*FTCS: Full Traction Control System

INSPECTION OF HECU TERMINALS

(HECU HARNESS SIDE CONNECTOR)

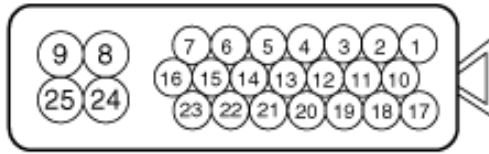

Terminals No.	Condition	Standard Voltage (V)
25 - GND (8,24)	Always	10 - 14
9 - GND (8,24)	Always	10 - 14
4 - GND (8,24)	Ignition switch ON	10 - 14
16 - GND (8,24)	Ignition switch ON, ABS warning lamp ON	3 - 5
18 - GND (8,24)	Stop lamp switch OFF	Below 1.0
	Stop lamp switch ON	8 - 14
19 - 20	Ignition switch ON, slowly turn right front wheel	AC voltage generation
1 - 2	Ignition switch ON, slowly turn left front wheel	AC voltage generation
22 - 23	Ignition switch ON, slowly turn right rear wheel	AC voltage generation
5 - 6	Ignition switch ON, slowly turn left rear wheel	AC voltage generation
14 - GND (8,24)	Ignition switch ON, TCS switch ON	10 - 14
GND (8,24) - Body ground	Always	Continuity

COMPONENTS

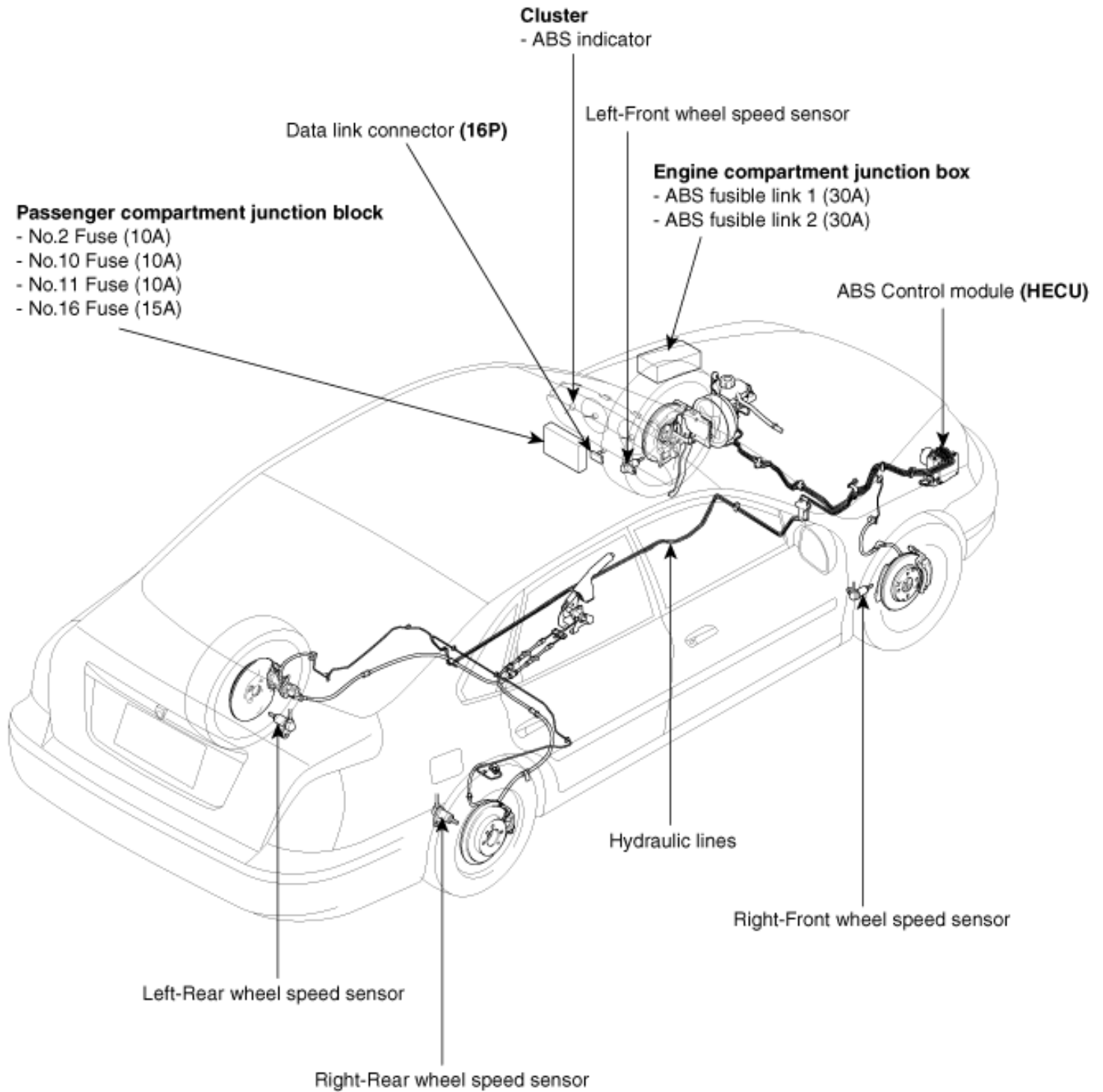



DESCRIPTION

This specification applies to Hydraulic and Electronic Control Unit (HECU) of the Anti lock Braking System(ABS) and Traction Control System(TCS).

This HECU has the functions as follows:

- Input of signal from the wheel speed sensors attached to each wheel.
- Control of braking force and traction force
- Failsafe function
- Self diagnosis function
- Interface with the external diagnosis tester

Operation

The HECU shall be put into operation by switching on the operating voltage (IGN).

On completion of the initialization phase, the HECU shall be ready for operation.

In the operating condition, the HECU shall be ready, within the specified limits (voltage and temperature), to process the signals offered by the various sensors and switches in accordance with the control algorithm defined by the software and to control the hydraulic and electrical actuators.

The HECU shall receive wheel speed signal from the four inductive wheel sensors.

The wheel signals are converted to square wave by the signal conditioning circuit and given as input to the μ - processor. The sensor connections shall be monitored for short-circuit and inter-ruption and then in the event of 2 sensor failures, the HECU shall shut down the system.

When one side of the valve coil is connected to the positive voltage that is provided through the valve relay and the other side is connected to the ground by the MOSFET, the solenoid valve goes into operation.

The electrical function of the valves are always monitored by the valve test pulse under normal operation conditions.

When overvoltage is detected(above 16V), the HECU switches off the valve relay and shuts down the system. When voltage is returned to operating range, the system goes back to the normal condition after the initialization phase.

In the event of undervoltage(below 10V), ABS control shall be inhibited and the warning lamp shall be turned on.

When voltage is returned to operating range, the warning lamp is switched off and the HECU returns to normal operating mode.

The pump motor operates when the ABS is functioning.

The HECU performs a pump motor test at a speed of 20km/h once after turned the Ignition switch on. You may hear the motor operate at this time, but it is normal.

Malfunctions or failures detected by the HECU are encoded on the HECU, stored in a EEPROM and read out by diagnostic equipment (hi-scan pro) when the ignition switch is turned on.

Warning lamp control

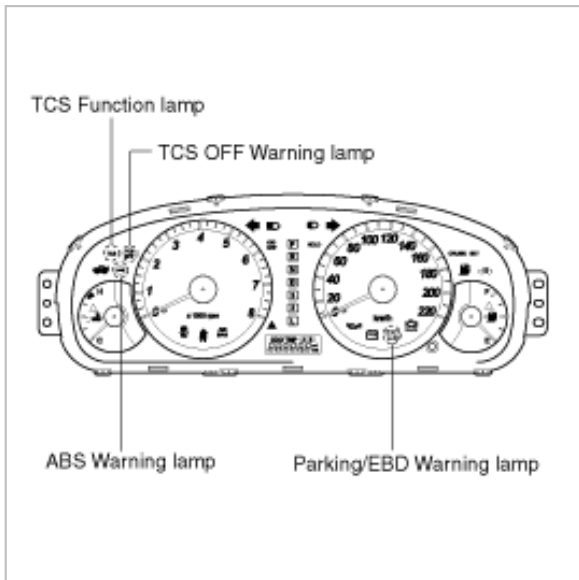

1. ABS warning lamp module

The ABS warning lamp module indicates the operating condition of the ABS.

The ABS warning lamp is turned on under the following conditions.

- During the initialization phase after ignition switch ON (3 seconds).
- In the event of inhibition of ABS functions by failure.
- When the system ECU is shut down even though ignition power is applied.
- During diagnostic mode.
- When the HECU connector is disconnected.

2. EBD warning lamp module

The EBD warning lamp module indicates the operating condition of the EBD. However, in case the parking brake switch is turned on, the EBD warning lamp is always turned on regardless of EBD functions.

The EBD warning lamp is turned on under the following conditions.

- During the initialization phase after ignition switch ON. (3 seconds).
- When the system ECU is shut down even though ignition power is applied.
- When the parking brake switch is ON or brake fluid is low level.
- In the event of inhibition of EBD functions by failure.

3. TCS lamp module

The TCS warning lamp module indicates the operating condition of the TCS.

The TCS warning lamp is turned on under the following conditions :

- During the initialization phase after ignition switch ON (3 seconds).
- In the event of inhibition of TCS functions by failure.
- When the TCS OFF switch is turned on.

TCS function lamp is turned on when the TCS functions are operating (Blinking-2Hz).

Diagnostic trouble code (DTC)

1. If the CPU cannot be activated or the CPU fails, the ABS indicator comes on, but the DTC is not memorized.

2. The memory can hold any number of DTCs. However, when the same DTC is detected more than once, the later one is written over the old one.

Therefore, when the same problem is detected repeatedly, it is memorized as one DTC.

3. The DTCs are indicated in the order they occur.

4. The DTCs are memorized in the EEPROM (non - volatile memory). Therefore, the memorized DTCs cannot be canceled by disconnecting the battery. Perform the specified procedures to erase the DTCs.

Self-diagnosis

Ebay User ID: reveleus1

1. Self diagnosis can be classified into two categories:
 - A. Initial diagnosis:
Performed right after the engine starts and until the ABS indicator goes off.
 - B. Regular diagnosis:
Performed right after the initial diagnosis until the ignition switch is turned OFF.
2. When a problem is detected by self-diagnosis, the system:
 - A. Turns the solenoid valve OFF
 - B. Turns the pump motor OFF
 - C. Turns the ABS indicator ON

How to troubleshoot ABS DTC

1. Question the customer about the conditions when the problem occurred, and try to reproduce the same conditions for troubleshooting. Find out when the ABS indicator came on, such as during initial diagnosis, during ABS control, after ABS control, when vehicle speed was at a certain speed, etc.
2. When the ABS indicator does not come on during the test-drive, but troubleshooting is performed based on the DTC. check for loose connectors, poor contact of the terminals, etc. before you start troubleshooting.
3. After troubleshooting, erase the DTC and test-drive the vehicle. Be sure the ABS indicator does not come on.

HI-SCAN (PRO) CHECK

1. Turn the ignition switch OFF.
2. Connect the Hi-scan (pro) to the 16P data link connector located behind the driver's side kick panel.

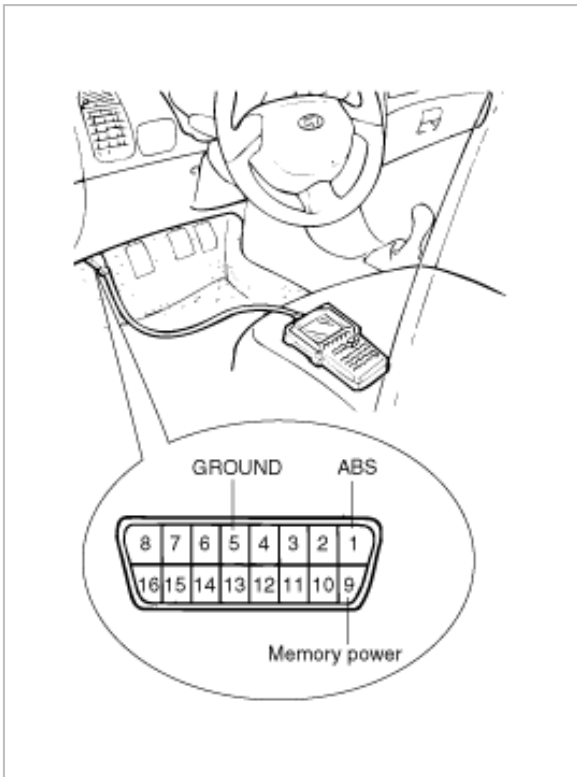

3. Turn the ignition switch ON.
4. Check for diagnostic trouble codes using the Hi-scan (pro).
5. After completion of the repair or correction of the problem, erase the stored fault codes using the clear key on the Hi-scan (pro).
6. Disconnect the Hi-scan (pro) from the 16P data link connector.

SYSTEM FUNCTION

ABS OPERATION

Ebay User ID: reveleus1

1. NORMAL BRAKING

Solenoid valve	State	Valve	Passage	Pump motor
IN (NO)	OFF	OPEN	Master cylinder ↔ Wheel cylinder	OFF
OUT (NC)	OFF	CLOSE	Wheel cylinder ↔ Reservoir	

Under the normal braking, voltage is not supplied to solenoid valve, inlet valve is opened and outlet valve is closed. When the brake is depressed, brake fluid is supplied to the wheel cylinder via solenoid valve to activate the brake. When the brake is released, brake fluid is back to the master cylinder via inlet valve and check valve.

2. DUMP MODE

Solenoid valve	State	Valve	Passage	Pump motor
IN (NO)	ON	CLOSE	Master cylinder ↔ Wheel cylinder	ON
OUT (NC)	ON	OPEN	Wheel cylinder ↔ Reservoir	

Under the emergency braking, if the wheels start to lock up, HECU sends a signal to the solenoid valve to decrease the brakefluid, then voltage is supplied to each solenoid. At this time inlet valve is closed and brake fluid is blocked from the master cylinder. Conversely outlet valve is opened and brake fluid passes through wheel cylinder to reservoir, resulting in pressure decrease.

3. HOLD MODE

Solenoid valve	State	Valve	Passage	Pump motor
IN (NO)	ON	CLOSE	Master cylinder ↔ Wheel cylinder	ON
OUT (NC)	OFF	CLOSE	Wheel cylinder ↔ Reservoir	

When the brake fluid pressure is maximally decreased in wheel cylinder, HECU sends a signal to solenoid valve to keep the fluidpressure, voltage is supplied to inlet valve but it is not supplied to outlet valve. At this time inlet and outlet valves are closed and brake fluid is kept in wheel cylinder.

4. INCREASE MODE

Solenoid valve	State	Valve	Passage	Pump motor
IN (NO)	OFF	OPEN	Master cylinder ↔ Wheel cylinder	ON
OUT (NC)	OFF	CLOSE	Wheel cylinder ↔ Reservoir	

If HECU determines there's no lock-up in the wheel, HECU cuts voltage to solenoid valve. So voltage is not supplied to each solenoid valve, brake fluid passes through the inlet valve to wheel cylinder, resulting in pressure increase.

TRACTION CONTROL SYSTEM (TCS) OPERATION

1. NORMAL MODE

Ebay User ID: reveleus1

Solenoid valve	State	Valve	Motor pump	TC valve
IN (NO)	OFF	OPEN	OFF	OFF
OUT (NC)	OFF	CLOSE		

- In the normal driving condition, TC valve (normally open) is the passage between the master cylinder and the each wheel cylinder.
- When brake pedal is applied, brake pressure is delivered to the wheel cylinders via NO-TC valve and all solenoid valves inside the hydraulic unit are deactivated.
- In case of TCS malfunction it does not affect brake operation.

2. PRESSURE INCREASE MODE

Solenoid valve	State	Valve	Motor pump	TC valve
IN (NO)	FRONT: OFF REAR: ON	FRONT: OPEN REAR: CLOSE	ON	ON
OUT (NC)	OFF	CLOSE		

- If a front wheel spin is detected, TCS begins a brake control to decrease a wheel spin.
- Hydraulic shuttle valve (HSV) is opened.
Brake fluid is supplied from the master cylinder by motor operation to the spin wheel via HSV.
- TC valve is closed (ON).
Brake pressure generated from motor pump is delivered only to the front wheel.
- Inlet valve remains open to deliver the brake pressure generated from motor pump to the spinning wheels.

3. PRESSURE DUMP MODE

Solenoid valve	State	Valve	Motor pump	TC valve
IN (NO)	ON	CLOSE	ON	ON
OUT (NC)	FRONT: ON REAR: OFF	FRONT: OPEN REAR: CLOSE		

- When the wheel deceleration is under the threshold and the wheel spin is reduced under a slip threshold, applied brake pressure is reduced to get a optimum traction force.
- Outlet valve is open to release the brake pressure and inlet valve is closed to block the pressure increase from the motor pump.
- Hydraulic shuttle valve (HSV) remains opened, TC valve is ON.
- Motor is ON, to dump the brake fluid being released from the lock-up wheel.

4. PRESSURE HOLD MODE

Ebay User ID: reveleus1

Solenoid valve	State	Valve	Motor pump	TC valve
IN (NO)	ON	CLOSE	ON	ON
OUT (NC)	OFF	CLOSE		

TRACTION CONTROL SYSTEM (TCS) FUNCTION

1. Main performance

- A. Traction: Lower vibration and higher launchability, acceleration and climbability by slip control.
- B. Cornering and passing: Stable cornering and passing.
- C. Steering stability: Control traction force traverse vector prior to provide easy turning when turning the steering wheel.

2. General TCS features

- A. Improved drivability. Minor operation of acceleration is not necessary in launching and acceleration on slippery road.
- B. More stable cornering by stable acceleration on normal road condition.
- C. TCS system will compare vehicle speed received from rear wheel speed sensor and driving wheel speed from front wheel speed sensor on slippery road condition, and provide optimum slipping rate of driving wheels.

FULL TRACTION CONTROL SYSTEM (FTCS)

1. The ABS control module (HECU) controls TCS control too.
2. HECU will compare signals from front (driving) and rear wheel speed sensors to detect driving wheels slip.
3. Upon detecting driving wheels slip, HECU will perform TCS control. The TCS control will include brake TCS (BTCS) control.
4. HECU will transmit engine torque reduction request, fuel cut cylinder number, and TCS control request signals in accordance with slip level to engine ECM and TCM through BUS line which will provide CAN communication for TCS control.
5. Engine ECM will perform fuel cut as requested by HECU and retard ignition timing as per engine torque reduction request signal.
6. TCM will hold shift position by TCS control time according to TCS operation signal. Then enhanced acceleration by kick-down will not occur.

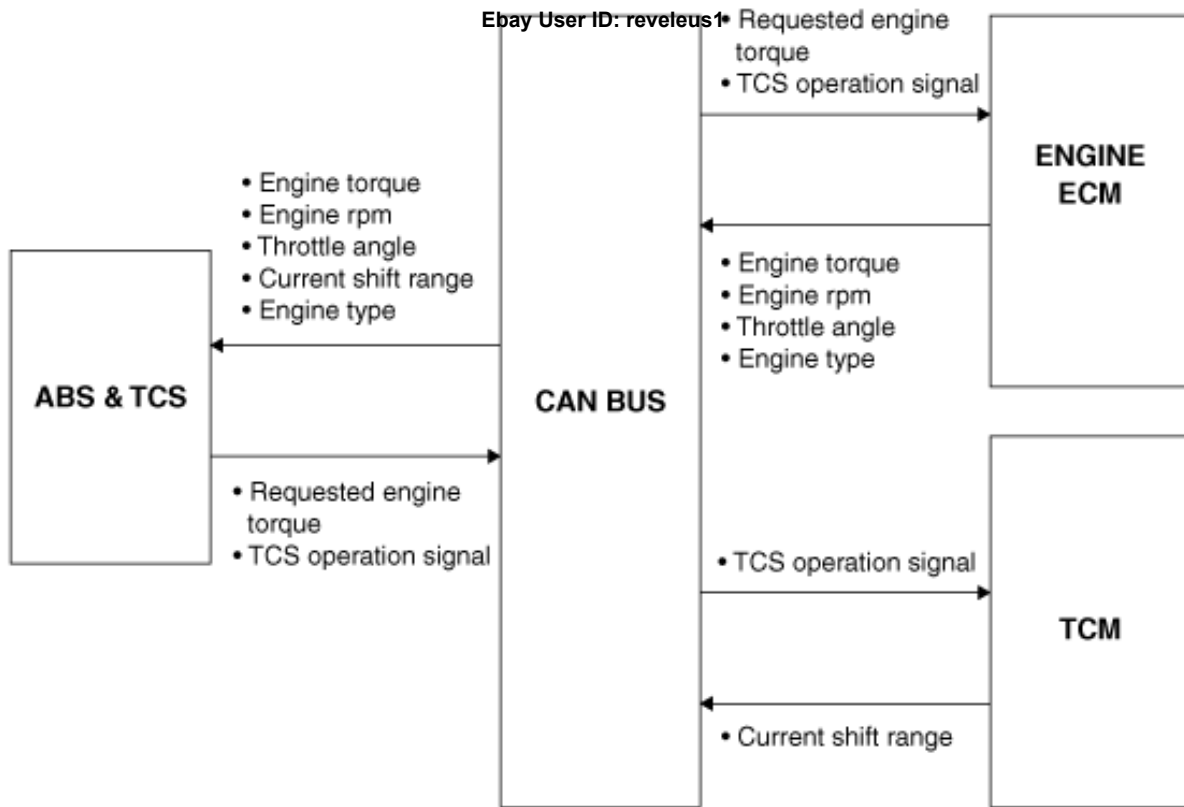

BRAKE TRACTION CONTROL SYSTEM (BTCS)

1. On TCS control, only brake control will be performed. (engine and TCM control will not happen)
2. Controlled by motor pump output pressure.

EBD (ELECTRONIC BRAKE-FORCE DISTRIBUTION) OPERATION

ADVANTAGES

- Function improvement of the base-brake system.
- Compensation for the different friction coefficients.
- Elimination of the proportioning valve.
- Failure recognition by the warning lamp.

Comparison between Proportioning valve and EBD

[With P-Valve]

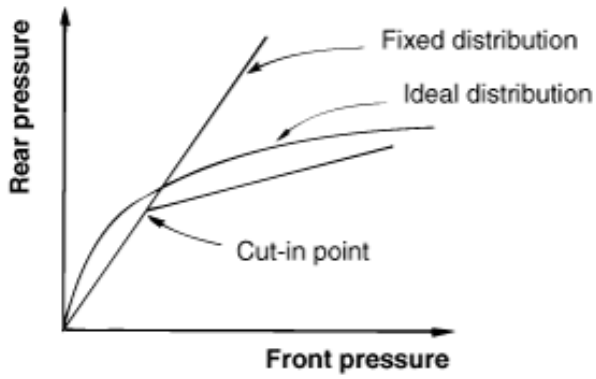

[With EBD]

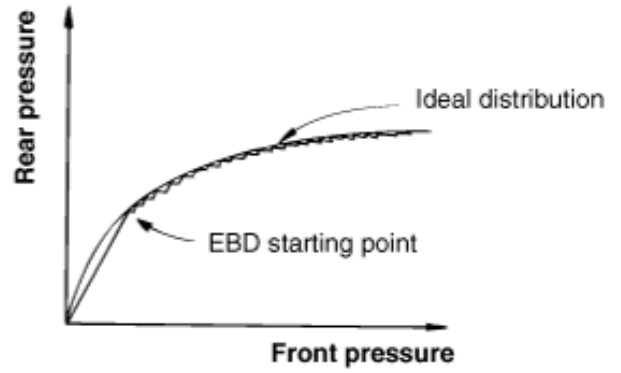

FAIL SAFE

FAIL CAUSE	SYSTEM		WARNING LAMP	
	ABS	EBD	ABS	EBD
None	ON	ON	OFF	OFF
1-Wheel speed sensor failure	OFF	ON	ON	OFF
Pump malfunction	OFF	ON	ON	OFF
Low voltage	OFF	ON	ON	OFF
2 or more wheel speed sensor failure Solenoid valve failure HECU malfunction Valve relay failure Over voltage Other failure	OFF	OFF	ON	ON

BLEEDING OF BRAKE SYSTEM

1. Remove the reservoir cap (A) and fill the brake reservoir with brake fluid.

CAUTION

If there is any brake fluid on any painted surface, wash it off immediately.

NOTE

When pressure bleeding, do not depress the brake pedal.

Recommended fluid..... DOT3 or DOT4

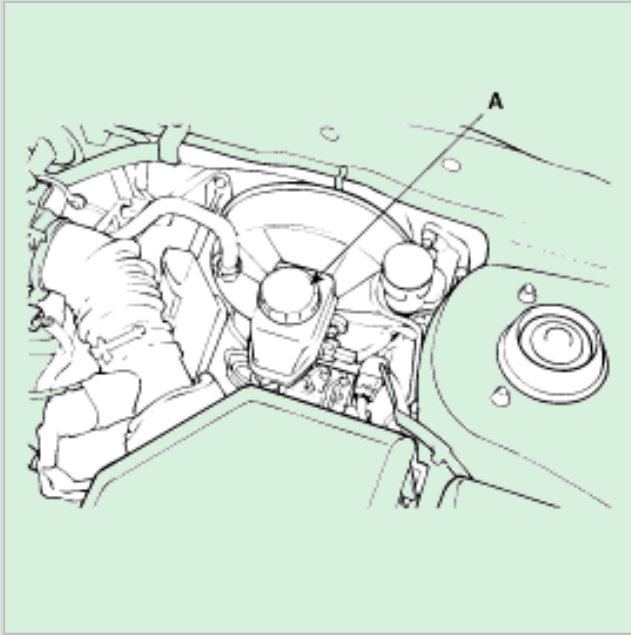

2. Connect a clear plastic tube to the wheel cylinder bleeder plug (A) and insert the other end of the tube into a half filled clear plastic bottle.

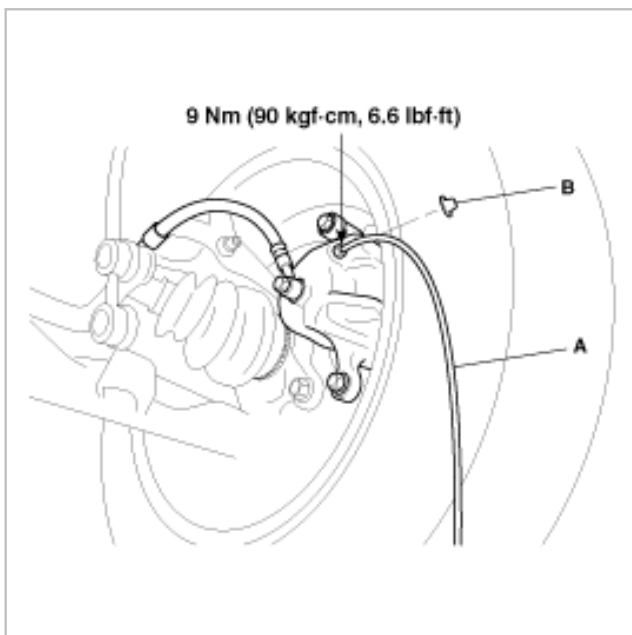

3. Connect the hi-scan (pro) to the data link connector located underneath the dash panel.

Ebay User ID: reveleus1

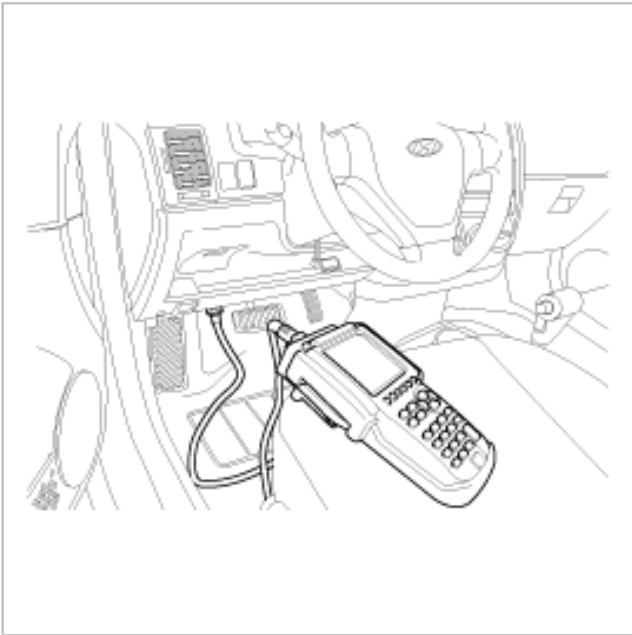

4. Select and operate according to the instructions on the hi-scan (Pro) screen.

CAUTION

You must obey the maximum operating time of the ABS motor with the hi-scan (Pro) to prevent the motor pump from burning.

(1) Select hyundai vehicle diagnosis.

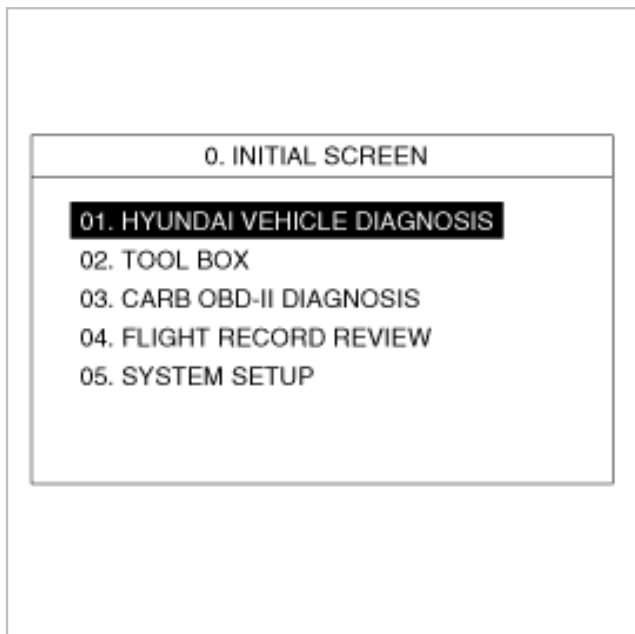

(2) Select vehicle name.

(3) Select Anti-Lock Brake system.

(4) Select air bleeding mode.

(5) Press "YES" to operate motor pump and solenoid valve.
Ebay User ID: reveleus1

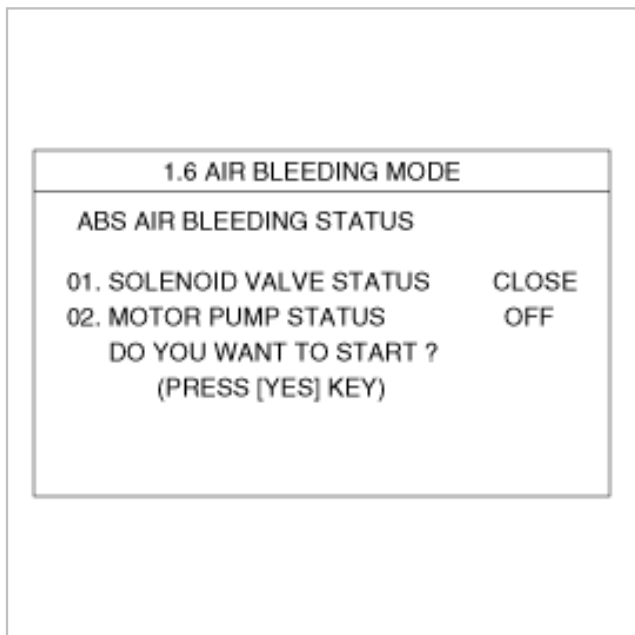

(6) Wait 60 sec. before operating the air bleeding.
(If not, you may damage the motor.)

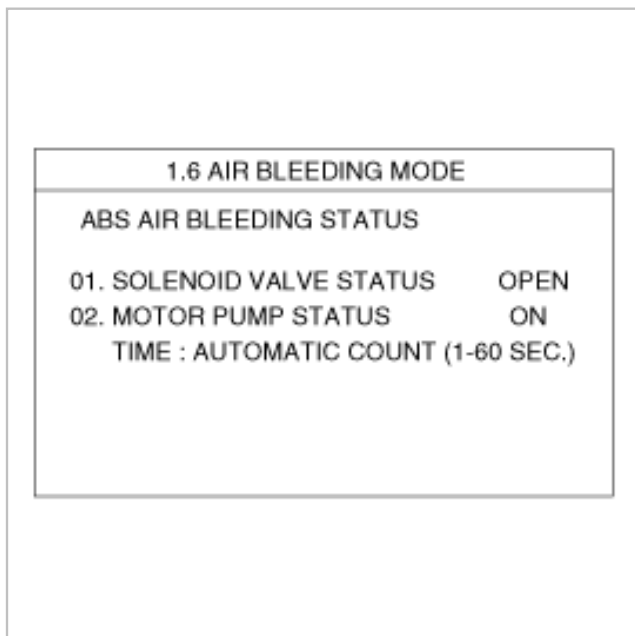

5. Pump the brake pedal several times, and then loosen the bleeder screw until fluid starts to run out without bubbles. Then close the bleeder screw.

6. Repeat step 5 until there are no more bubbles in the fluid for each wheel.
Ebay User ID: reveleus1

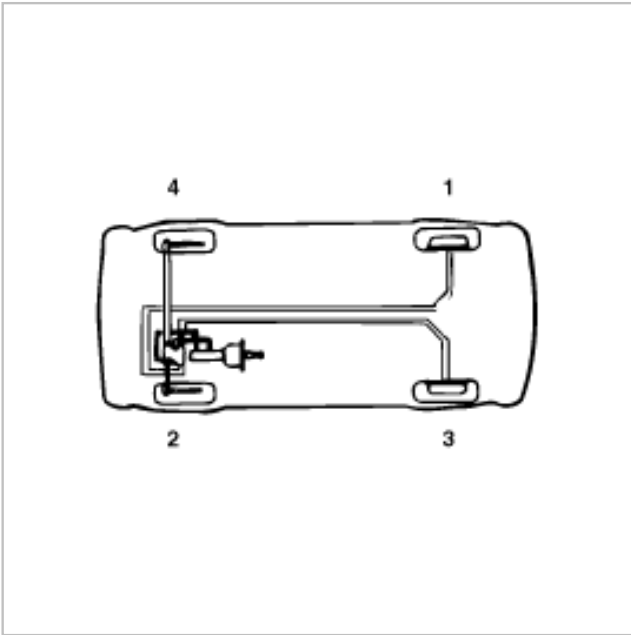

7. Tighten the bleeder screw.

Bleed screw tightening torque:

7 ~ 13 Nm (70 ~130 kg·cm, 5.1 ~ 9.5 lb·ft)

HYDRAULIC SYSTEM DIAGRAM

<With ABS>

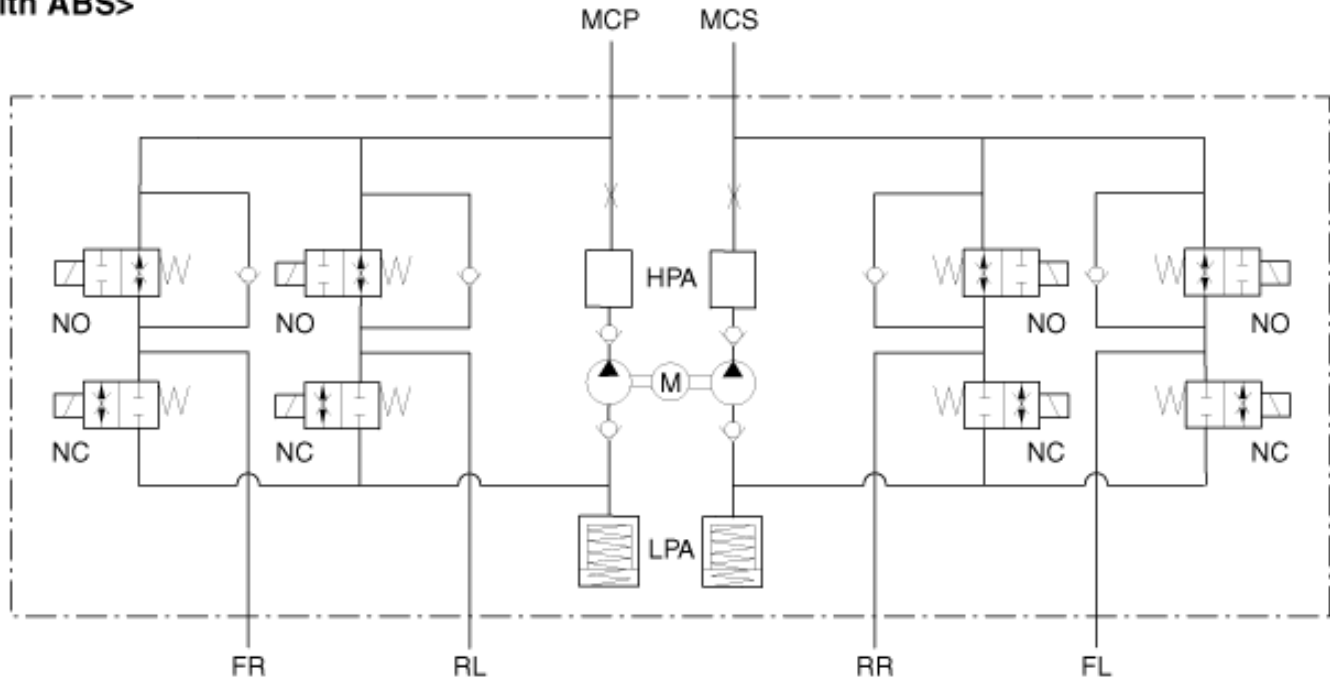

<With ABS+TCS>

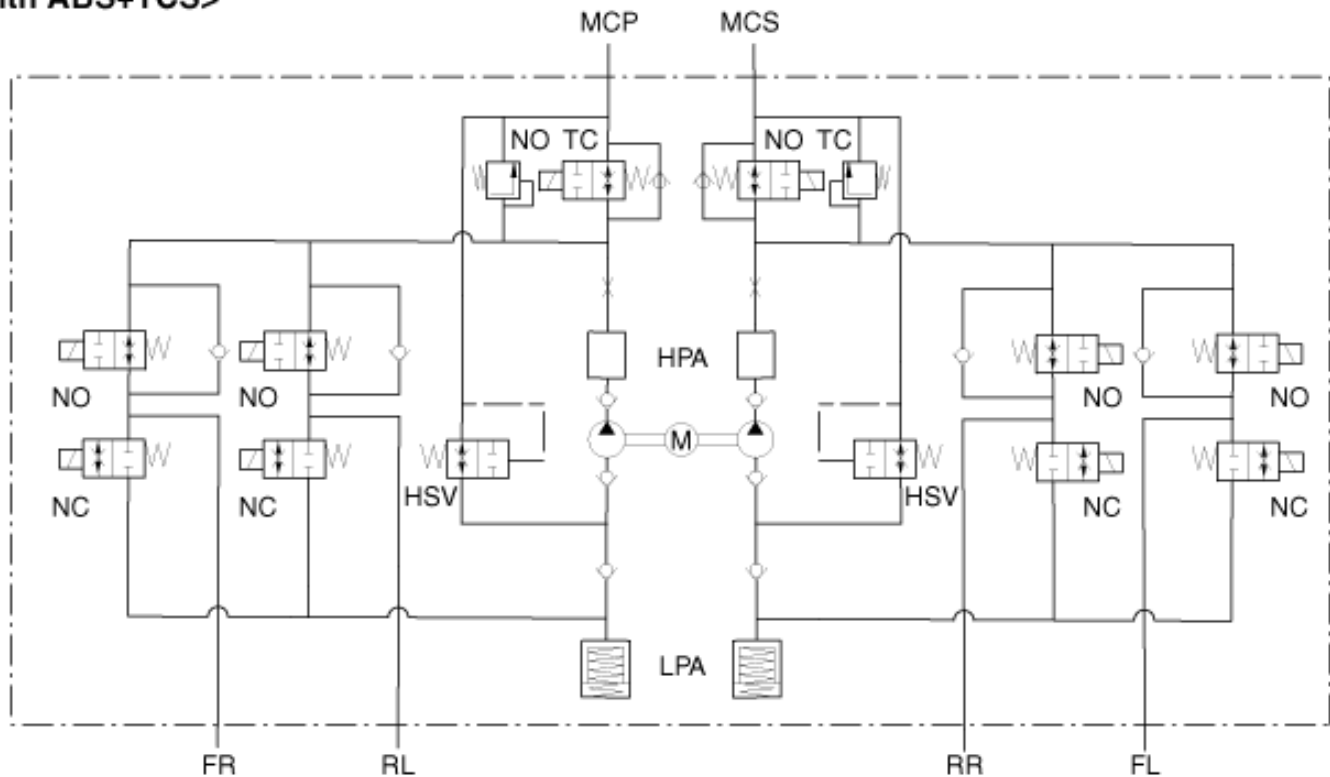

TCS : Traction Control System
 MCP : Master Cylinder Primary
 MCS : Master Cylinder Secondary
 HPA : High Pressure Accumulator
 LPA : Low Pressure Accumulator

M : Motor Pump
 HSV : Hydraulic Shuttle Valve
 TC : Traction Control valve
 NO : Normal Open valve
 NC : Normal Close valve

CIRCUIT DIAGRAM

Ebay User ID: reveleus1

CIRCUIT DIAGRAM (1)

CIRCUIT DIAGRAM (2)



TROUBLESHOOTING

STANDARD FLOW OF DIAGNOSTIC TROUBLESHOOTING

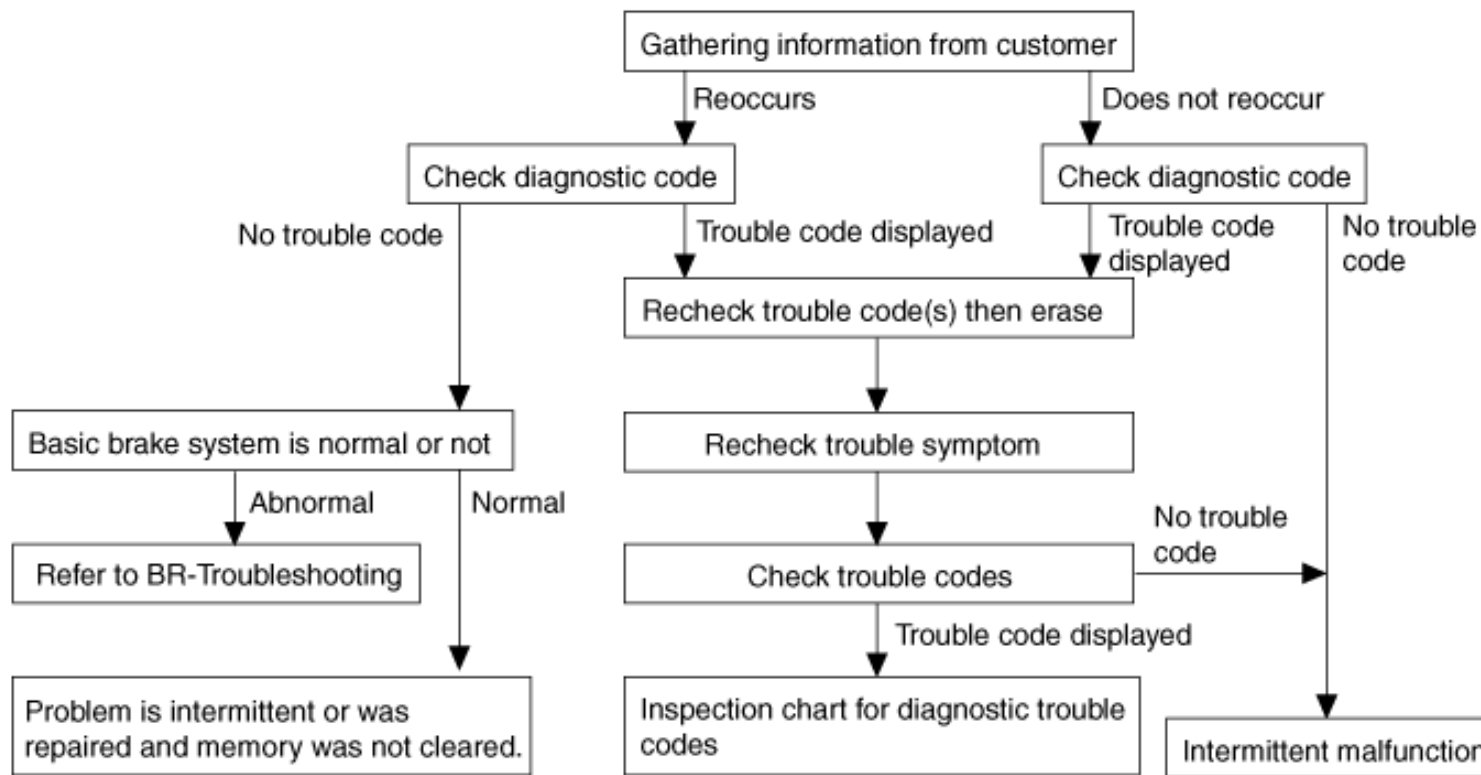

* Using the customer problem analysis check sheet for reference, ask the customer as much detail as possible about the problem.

NOTES WITH REGARD TO DIAGNOSIS

Phenomenon	Explanation
System check sound	When starting the engine, a thudding sound can sometimes be heard coming from inside the engine compartment. This is because the system operation check is being performed.
ABS operation sound	1. Sound of the motor inside the ABS hydraulic unit operation (whine). 2. Sound is generated along with vibration of the brake pedal (scraping). 3. When ABS operates, sound is generated from the vehicle chassis due to repeated brake application and release (Thump : suspension; squeak: tires)
ABS operation (Long braking distance)	For road surfaces such as snow-covered and gravel roads, the braking distance for vehicles with ABS can sometimes be longer than that for other vehicles. Accordingly, advise the customer to drive safely on such roads by lowering the vehicle speed.

Pedal kick back

Pedal kick back is normal operation.
Ebay User ID: reverend1

Diagnosis detection conditions can vary depending on the diagnosis code. When checking the trouble symptom after the diagnosis code has been erased, ensure that the requirements listed in "Comment" are met.

ABS CHECK SHEET

ABS Check Sheet

Inspector's
Name _____

Customer's Name		Registration No.	
		Registration Year	/ /
		VIN.	
Date Vehicle Brought In	/ /	Odometer	Km Miles

Date the Problem First Occurred	/ /
Frequency of Occurrence of Problem	<input type="checkbox"/> Continuous <input type="checkbox"/> Intermittent (times a day)

Symptoms	<input type="checkbox"/> ABS does not operate.		
	<input type="checkbox"/> ABS does not operate efficiently.		<input type="checkbox"/> Intermittent (times a day)
	ABS Warning Light Abnormal	<input type="checkbox"/> Remains ON	<input type="checkbox"/> Does not light up

Diagnostic Trouble Code Check	1st Time	<input type="checkbox"/> Normal Code	<input type="checkbox"/> Malfunction Code (Code)
	2nd Time	<input type="checkbox"/> Normal Code	<input type="checkbox"/> Malfunction Code (Code)

PROBLEM SYMPTOMS TABLE

Symptom	Suspect Area	See page
---------	--------------	----------

ABS does not operate.	Only when 1. -4. are all normal and the problem is still occurring, replace the HECU. 1. Check the DTC reconfirming that the normal code is output. 2. Power source circuit. 3. Speed sensor circuit. 4. Check the hydraulic circuit for leakage.	BR - 59
ABS does not operate intermittently.	Only when 1. -4. are all normal and the problem is still occurring, replace the ABS actuator assembly. 1. Check the DTC reconfirming that the normal code is output. 2. Wheel speed sensor circuit. 3. Stop lamp switch circuit. 4. Check the hydraulic circuit for leakage.	BR - 61
Communication with Hi-scan (pro) is not possible. (Communication with any system is not possible)	1. Power source circuit 2. Diagnosis line	BR - 63
Communication with Hi-scan (pro) is not possible. (Communication with ABS only is not possible)	1. Power source circuit 2. Diagnosis line 3. HECU	BR - 64
When ignition key is turned ON (engine OFF), the ABS warning lamp does not light up.	1. ABS warning lamp circuit 2. HECU	BR - 66
Even after the engine is started, the ABS warning lamp remains ON.	1. ABS warning lamp circuit 2. HECU	BR - 68
Brake warning lamp is abnormal.	1. Brake oil level sensor 2. Parking brake switch 3. Brake warning lamp circuit	BR - 70

CAUTION

During ABS operation, the brake pedal may vibrate or may not be able to be depressed. Such phenomena are due to intermittent changes in hydraulic pressure inside the brake line to prevent the wheels from locking and is not an abnormality.

DIAGNOSTIC TROUBLE CODE CHART

DTC No.	Detection Item	MIL*	Memory	See page
C1101	Battery voltage over volt: 18V or more			BR-
C1102	Battery voltage low volt: 9.5V or less			BR-

C1200	FL wheel sensor: open or short to ground	EBay User ID: reveleus1		BR-
C1201	- Range/Performance: speed jump or damaged exciter			BR-
C1202	- No signal: air-gap error or wrong excite			BR-
C1203	FR wheel sensor: open or short to ground			BR-
C1204	- Range/Performance: speed jump or damaged exciter			BR-
C1205	- No signal excite: air-gap error or wrong excite			BR-
C1206	RL wheel sensor: open or short to ground			BR-
C1207	- Range/Performance: speed jump or damaged exciter			BR-
C1208	- No signal excite: air-gap error or wrong excite			BR-
C1209	RR wheel sensor: open or short to ground			BR-
C1210	- Range/Performance: speed jump or damaged exciter			BR-
C1211	- No signal: air-gap error or wrong excite			BR-
C1604	ECU hardware: ECU internal or valve failure			BR-
C2112	Valve relay: valve relay or fuse failure			BR-
C2402	Motor-Electrical: open or short to battery, motor relay, fuse or motor lock fail			BR-
C1503	TCS switch failure	×		BR-
C1605	CAN Hardware failure	Δ		BR-
C1610	CAN Bus off failure	Δ		BR-
C1611	EMS Time-out failure	Δ		BR-
C1612	TCM Time-out failure	Δ		BR-
C1613	TCM Un-matching failure	Δ		BR-
C2227	Brake disc overheat	Δ		BR-

NOTE

*MIL: Malfunction Indication Lamp

: ABS warning lamp

Δ: TCS warning lamp

ABS Does Not Operate

DETECTING CONDITION

Trouble Symptoms	Possible Cause

Brake operation varies depending on driving conditions and road surface conditions, so diagnosis can be difficult. However if a normal DTC is displayed, check the following probable cause. When the problem is still occurring, replace the ABS control module.

Ebay User ID: reVeLeus1

- Faulty power source circuit
- Faulty wheel speed sensor circuit
- Faulty hydraulic circuit for leakage
- Faulty HECU

INSPECTION PROCEDURES

1. CHECK THE DTC RECONFIRMING THAT THE NORMAL CODE IS OUTPUT.

1. Connect the Hi-Scan (pro) with the data link connector and turn the ignition switch ON.
2. Verify that the normal code is output.

Is the normal code output?



No

Erase the DTC and recheck using Hi-Scan (pro).

2. CHECK THE POWER SOURCE CIRCUIT.

1. Disconnect the connector from the ABS control module.
2. Turn the ignition switch ON, measure the voltage between terminal 4 of the ABS control module harness side connector (E37) and body ground.

- **Specification: approximately B+**

Is the voltage within specification?

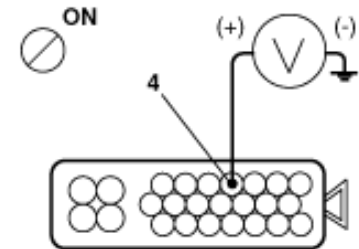

No

Check the harness or connector between the No.11 fuse (10A) in the passenger compartment junction block and the ABS control module. Repair if necessary.

3. CHECK THE GROUND CIRCUIT.

1. Disconnect the connector from the ABS control module.
2. Check for continuity between terminals 8,24 of the ABS control module harness side connector (E37) and ground point (G17).

Is there continuity?

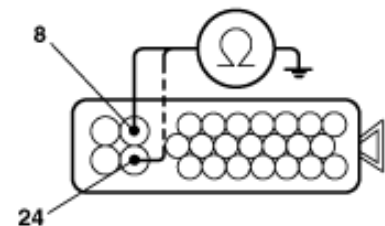

No

Repair an open in the wire and ground point (G17).

4. CHECK THE WHEEL SPEED SENSOR CIRCUIT.

Refer to the DTC troubleshooting procedures.(see page BR- 75)



NG

Repair or replace the wheel speed sensor.

5. CHECK THE HYDRAULIC CIRCUIT FOR LEAKAGE.

Refer to the hydraulic lines. (see page BR- 44)



NG

Repair the hydraulic lines for leakage.

The problem is still occurring, replace the ABS control module.

ABS Does Not Operate Intermittently**DETECTING CONDITION**

Trouble Symptoms	Possible Cause
Brake operation varies depending on driving conditions and road surface conditions, so diagnosis can be difficult. However if a normal DTC is displayed, check the following probable cause. When the problem is still occurring, replace the ABS control module.	<ul style="list-style-type: none"> - Faulty wheel speed sensor circuit - Faulty stop lamp switch circuit - Faulty hydraulic circuit for leakage - Faulty HECU

INSPECTION PROCEDURES**1. CHECK THE DTC RECONFIRMING THAT THE NORMAL CODE IS OUTPUT.**

1. Connect the Hi-Scan (pro) to the data link connector and turn the ignition switch ON.
2. Verify that the normal code is output.

Is the normal code output?



No

Erase the DTC and recheck using Hi-Scan (pro).

2. CHECK THE WHEEL SPEED SENSOR CIRCUIT.

Refer to the DTC troubleshooting procedures. (see page BR- 75)



NG	Repair or replace the wheel speed sensor.
----	---

3. CHECK THE STOP LAMP SWITCH CIRCUIT.

1. Check that stop lamp lights up when brake pedal is depressed and turns off when brake pedal is released.
2. Measure the voltage between terminal 18 of the ABS control module harness side connector (E37) and body ground when brake pedal is depressed.

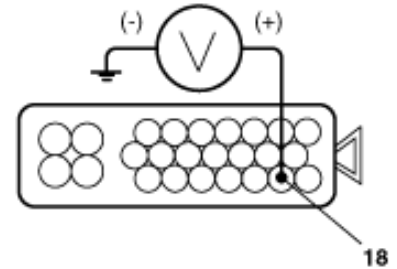

• **Specification: approximately B+**

Is the voltage within specification?



No	Repair the stop lamp switch. Repair an open in the wire between the ABS control module and the stop lamp switch.
----	---

4. CHECK THE HYDRAULIC CIRCUIT FOR LEAKAGE.

Refer to the hydraulic lines. (see page BR- 44)



NG	Repair the hydraulic lines for leakage.
----	---

The problem is still occurring, replace the ABS control module.

**Communication With Hi-Scan (pro) Is Not Possible.
(Communication With Any System Is Not Possible)**

DETECTING CONDITION

Trouble Symptoms	Possible Cause
Possible defect in the power supply system (including ground) for the diagnosis line.	-An open in the wire -Poor ground (G14)

INSPECTION PROCEDURES

1. CHECK THE POWER SUPPLY CIRCUIT FOR THE DIAGNOSIS

Measure the voltage between terminal 9 of the data link connector (M07) and body ground.

- **Specification: approximately B+**

Is voltage within specification?

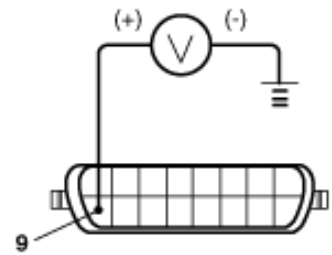

Yes

No Repair an open in the wire.
Check and replace fuse (15A) from the passenger compartment junction block

2. CHECK THE GROUND CIRCUIT FOR THE DIAGNOSIS

Check for continuity between terminal 5 of the data link connector (M07) and body ground.

Is there continuity?

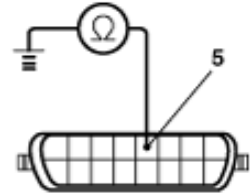

No Repair an open in the wire between terminal 5 of the data link connector (M07) and ground point (G14).

**Communication With Hi-Scan (pro) Is Not Possible.
(Communication With ABS Only Is Not Possible)**

DETECTING CONDITION

Trouble Symptoms	Possible Cause
When communication with Hi-Scan (pro) is not possible, the cause may be probably an open in the HECU power circuit or an open in the diagnosis output circuit.	-An open in the wire -Blown No.11 fuse (10A) in the passenger compartment junction block -Faulty HECU

INSPECTION PROCEDURES

1. CHECK FOR CONTINUITY IN THE DIAGNOSIS LINE

1. Disconnect the connector from the ABS control module.
2. Check for continuity between terminals 7 of the ABS control module connector (E37) and 1 of the data link connector (M07).

Is there continuity?

Yes

No Repair an open in the wire.

2. CHECK THE POWER SOURCE OF ABS CONTROL MODULE

1. Disconnect the connector from the ABS control module.
2. Turn the ignition switch ON, measure the voltage between terminal 4 of the ABS control module harness side connector (E37) and body ground.

• **Specification: approximately B+**

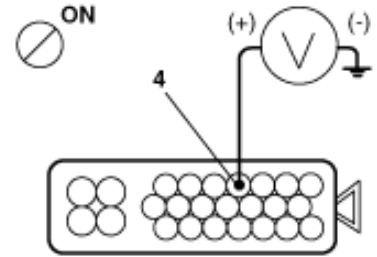

Is voltage within specification?

Yes

No

Check the harness or connector between the No.11 fuse (10A) in the passenger compartment junction block and the ABS control module.
Repair if necessary.

3 . CHECK FOR POOR GROUND

Check for continuity between terminal 5 of the data link connector (M07) and ground point (G14).

Is there continuity?

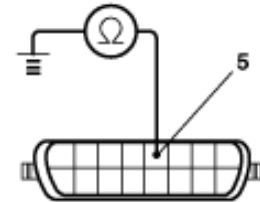

Yes

No

Repair an open in the wire or poor ground.

Replace the ABS control module and recheck.

When Ignition Key Is Turned ON (Engine OFF), The ABS Warning Lamp Does Not Light Up.

DETECTING CONDITION

Trouble Symptoms	Possible Cause
When current flows in the HECU the ABS warning lamp turns from ON to OFF as the initial check. Therefore if the lamp does not light up, the cause may be an open in the lamp power supply circuit, a blown bulb, an open in the both circuits between the ABS warning lamp and the HECU, and the faulty HECU.	-Blown No.2 fuse (10A) in the passenger compartment junction block -An open in the wire -Faulty ABS warning lamp bulb -Faulty ABS warning lamp module -Faulty HECU

INSPECTION PROCEDURES

1 . PROBLEM VERIFICATION

Disconnect the connector from the ABS control module and turn the ignition switch ON.

Does the ABS warning lamp light up?

No

Yes Check for short circuit in the ABS control module connector.

2 . CHECK THE POWER SOURCE FOR THE ABS WARNING LAMP

1. Disconnect the instrument cluster connector (M10-1) and turn the ignition switch ON.
2. Measure the voltage between terminal 3 of the cluster harness side connector (M10-1) and body ground.

• **Specification: approximately B+**

Is voltage within specification?

No

Yes Repair bulb or instrument cluster assembly.

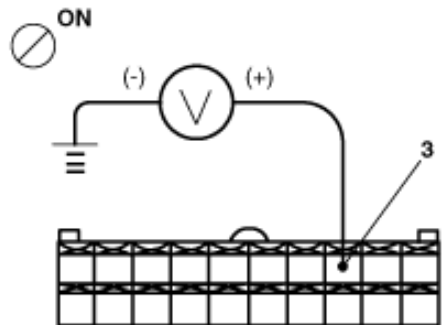

3 . CHECK FOR BLOWN FUSE

Check continuity of No.2 fuse (10A) from the passenger compartment junction block (A).

Is there continuity?

Yes

No Replace the blown fuse.

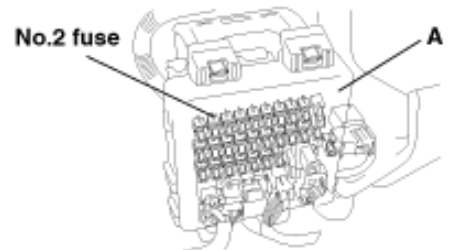

Repair an open in the wire between terminals 12 of I/P-H connector and 3 of cluster connector (M10-1).

Even After The Engine Is Started, The ABS Warning Lamp Remains ON.

DETECTING CONDITION

Trouble Symptoms

Possible Cause

If the HECU detects trouble, it lights the ABS warning lamp while at the same time prohibiting ABS control. At this time, the HECU records a DTC in memory.

Even though the normal code is output, the ABS warning lamp remains ON, then the cause may be probably an open or short in the ABS warning lamp circuit.

- An open in the wire
- Faulty instrument cluster assembly
- Faulty HECU

INSPECTION PROCEDURES

1 . CHECK DTC OUTPUT.

1. Connect the Hi-Scan (pro) to the 16P data link connector located behind the driver's side kick panel.
2. Check the DTC output using Hi-Scan (pro).

Is DTC output?

No

Yes

Repair circuit indicated by code output.

2 . CHECK INSTRUMENT CLUSTER

Disconnect the cluster connector (M10-1) and turn the ignition switch ON.

Does the ABS warning lamp remains ON?

No

Yes

Replace the instrument cluster.

3 . CHECK FOR OPEN IN THE WIRE

Check for continuity in the wire between cluster and ABS control module.

Is there continuity?

Yes

No

Repair an open in the wire between cluster and ABS control module.

Replace the ABS control module and recheck.

Brake Warning Lamp Is Abnormal**DETECTING CONDITION**

Trouble Symptoms	Possible Cause
The brake warning lamp lights up when the brake oil is insufficient, parking brake is applied or EBD is defective.	<ul style="list-style-type: none"> - Faulty brake oil level sensor - Faulty parking brake switch - Faulty instrument cluster - Faulty HECU

INSPECTION PROCEDURES**1. CHECK PARKING BRAKE SWITCH CIRCUIT**

NG

Repair or replace parking brake switch circuit.

2. CHECK BRAKE OIL LEVEL WARNING SWITCH CIRCUIT

NG

Repair or replace brake oil level warning switch circuit.

3. CHECK BRAKE WARNING LAMP CIRCUIT IN CLUSTER

NG

Repair or replace the instrument cluster.

4. CHECK FOR OPEN OR SHORT CIRCUIT IN HARNESS AND CONNECTOR

NG

Repair or replace the harness and connector.

Replace the ABS control module and recheck.

DTC

C1101
(Over Voltage)
C1102
(Low Voltage)

Ebay User ID: reveleus1

Battery Voltage out of Range (Low or Over Voltage)

DESCRIPTION

The voltage of the HECU power supply drops lower than or rises higher than the specified value. If the voltage returns to the specified value, this code is no longer output.

CAUTION

If battery voltage drops or rises during inspection, this code will be output as well. If the voltage returns to the standard value, the code is no longer output. Before carrying out the following inspection, check the battery level, and refill if necessary.

DTC DETECTING CONDITION

DTC No	Detecting Condition	Possible Cause
C1101 (Over Voltage) C1102 (Low Voltage)	<p>Detecting Condition for Over Voltage:</p> <ol style="list-style-type: none"> 1. When Vign>17V is continued for 500msec. 2. When Vign>19V is continued for 49msec. 3. If the voltage recover normal operating range, the controller is reset. <p>Detecting Condition for Low Voltage:</p> <ol style="list-style-type: none"> 1. When Vign<9.4V is continued for 500msec. 2. When Vign>9.6V is continued for 500msec, the controller recovers to normal state. 3. During ABS control or standstill, detection voltage = 8.4V, recovery voltage = 8.6V. 4. When Vign<7.2V is continued for 28msec. 5. When Vign>7.5V is continued for 28msec, the controller recovers to state 1). 	<ul style="list-style-type: none"> -An open or short in the wire -Faulty power supply circuit -Faulty HECU

FAILSAFE FUNCTION

Over voltage failure:

System down. both the ABS(,TCS) and the EBD function are inhibited and the ABS(,TCS) and the EBD warning lamps is activated. In this failure, the valve relay and all solenoids are prevented from being switched on.

Low voltage failure:

1. Outside the ABS control cycle : inhibit the ABS(,TCS) control of front wheels and allow the ABS control of rear wheels, deactivating the motor, and the ABS(,TCS) warning lamp is switched on. When the voltage recover to the normal operating range, enable ABS function and ABS(,TCS) warning lamp is switched off and erase the error code.
2. Inside the ABS control cycle : inhibit ABS control of the front wheels and allow ABS control of the rear wheels, deactivating the motor. the ABS(,TCS) warning lamp is directly switched on and the state keeps continuously. the error code is always stored.

1 . CHECK NO.11 FUSE (10A) FROM JUNCTION BLOCK.

Check continuity of No.11 fuse (10A) from passenger compartment junction block (A).

Is there continuity?

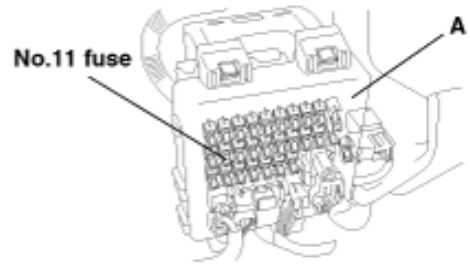

Yes

No

Check for short circuit in all the harness and components connected to No.11 fuse

2 . CHECK BATTERY POSITIVE VOLTAGE.

Is battery voltage within 10~14V?

Yes

No

Check and repair the charging system.

3 . CHECK FOR VOLTAGE BETWEEN TERMINALS OF HECU HARNESS SIDE CONNECTOR.

1. Disconnect the connector from the ABS control module.
2. Turn the ignition switch ON.
3. Measure the voltage between terminals 4 and 8, 24 of the ABS control module harness side connector.

• **Specification: approximately B+**

Is the voltage within specification?

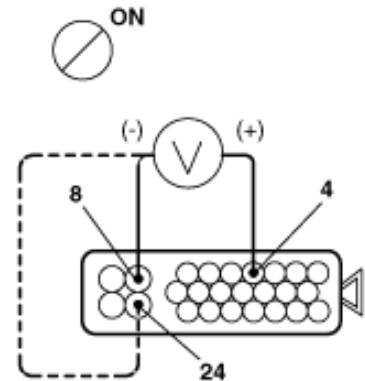

No

Yes

Check and replace the ABS control module.

4 . CHECK FOR CONTINUITY BETWEEN TERMINALS OF HECU CONNECTOR AND BODY GROUND.

Measure the resistance between terminals 8, 24 of ABS control module harness side connector and body ground.

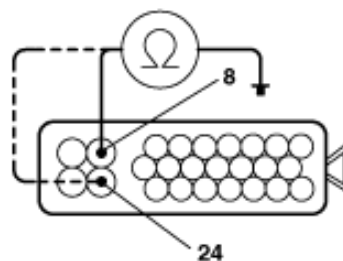

- **Specification:** 1Ω or less

Is the resistance within specification?

Yes

No

Repair an open in the wire or faulty ground point.

5 . CHECK FOR OPEN CIRCUIT BETWEEN TERMINAL OF HECU CONNECTOR AND NO. 11 FUSE.

Check for open circuit in harness and connector between terminal 4 of ABS control module harness side connector and No.11 fuse (10A) in the passenger compartment junction block (A).



DTC

C1200 (FL)
C1203 (FR)
C1206 (RL)
C1209 (RR)

Wheel Speed Sensor Open or Short to Ground

DESCRIPTION

The wheel speed sensor detects wheel speed and sends the appropriate signals to the HECU. These signals are used to control of the ABS system. The front and rear rotors each have 44 serrations.

When the rotors rotate, the magnetic field emitted by the permanent magnet in the speed sensor generates an AC voltage.

Since the frequency of this AC voltage changes in direct proportion to the speed of the rotor, the frequency is used by HECU to detect the speed of each wheel.

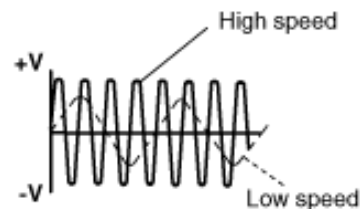
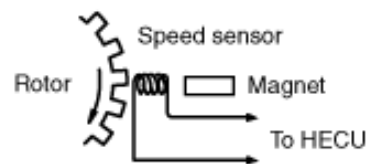

DTC DETECTING CONDITION

DTC No	Detecting Condition	Possible Cause
C1200 (FL) C1203 (FR) C1206 (RL) C1209 (RR)	The wheel velocity is below 7km/h and the offset voltage of the sensor is outside the permitted range. if this condition is continued for more than 140msec.	-An open or short in the wire -Faulty wheel speed sensor -Faulty HECU

Sensor failure outside the ABS control cycle:

1. Only one wheel failure

Only the ABS,(TCS) function is inhibited. the ABS,(TCS) warning lamp is activated and the EBD warning lamp not activated.

2. More than two wheels failure

System down. both the ABS,(TCS) and the EBD function are inhibited and the ABS,(TCS) and the EBD warning lamps is activated. In this failure, the valve relay and all solenoids are prevented from being switched on.

Sensor failure inside the ABS control cycle:

1. One front wheel failure

Inhibit the ABS control of the failed-wheel and maintain the ABS control of normal wheel.

After the controller completes the ABS control, the ABS,(TCS) function is inhibited. the ABS,(TCS) warning lamp is activated and the EBD warning lamp not activated.

2. One rear wheel failure

Inhibit ABS control of both front wheels and the pressure of both rear wheels is decreased.

After the controller completes the ABS control, Only the ABS,(TCS) function is inhibited. the ABS,(TCS) warning lamp is activated and the EBD warning lamp not activated.

3. More than two wheels failure.

System down. both the ABS,(TCS) and the EBD function are inhibited and the ABS,(TCS) and the EBD warning lamps is activated. In this failure, the valve relay and all solenoids are prevented from being switched on.

INSPECTION PROCEDURES

1. PROBLEM VERIFICATION

1. Disconnect the ABS control module connector (E37).
2. Start the engine.
3. Measure the voltage between the appropriate wheel sensor(+) circuit terminal and body ground (see table).

DTC	Terminal
C1200 (Front - left)	1
C1203 (Front - right)	19
C1206 (Rear - left)	5
C1209 (Rear - right)	23

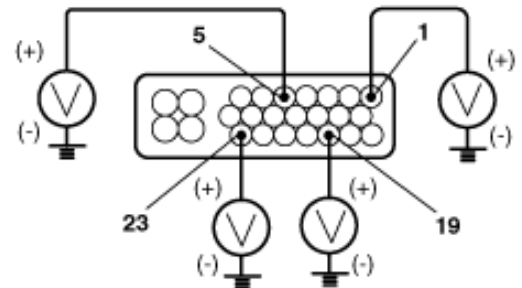

Is there 2V or more?



Yes

Repair short to power in the (+) circuit wire between the ABS control module and the appropriate wheel sensor.

2. CHECK CIRCUIT FOR SHORT TO GROUND.

Check for continuity between the appropriate wheel sensor(+) circuit terminal and body ground (see table).

DTC	Terminal
C1200 (Front - left)	1
C1203 (Front - right)	19
C1206 (Rear - left)	5
C1209 (Rear - right)	23

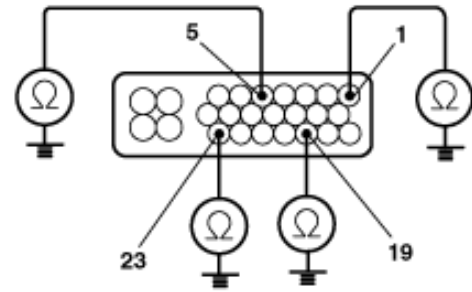

Is there continuity?

Yes

Disconnect the harness 2P connector from the appropriate wheel sensor, then check for continuity between the (+) and (-) terminals of the harness and body ground.

Is there continuity?

Yes

No

Replace the wheel sensor.

No

Repair short to body ground in the (+) or (-) circuit wire between the ABS control module and the wheel sensor.

3. CHECK THE RESISTANCE BETWEEN TERMINALS OF HECU.

Check the resistance between the appropriate wheel sensor (+) and (-) circuit terminals. (see table)

DTC	Terminal	
	(+) side	(-) side
C1200 (Front - left)	1	2
C1203 (Front - right)	19	20
C1206 (Rear - left)	5	6
C1209 (Rear - right)	23	22

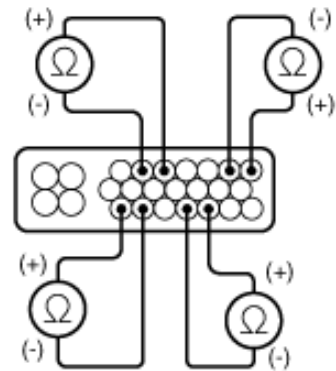

Is the resistance within 1,275~1,495Ω ?

No

Yes

Check for loose ABS control module connectors.
If necessary, substitute a known-good ABS control module and recheck.

4 . CHECK THE RESISTANCE BETWEEN TERMINALS OF WHEEL SENSOR

Disconnect the harness 2P connector from the appropriate wheel sensor, and check the resistance between the (+) and (-) terminals of the wheel sensor.

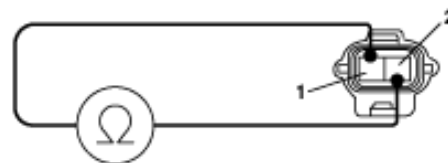

Is the resistance within 1,275~1,495Ω ?

Yes

No Replace the wheel sensor.

5 . REPAIR AN OPEN OR SHORT IN THE WIRE.

Repair open in the (+) or (-) circuit wire, or short between the (+) circuit wire and the (-) circuit wire between the ABS control module and the wheel sensor.

DTC	C1201 (FL) C1204 (FR) C1207 (RL) C1210 (RR)	Wheel Speed Sensor Signal Malfunction (Speed jump or damaged exciter)
-----	--	---

DTC DETECTING CONDITION

DTC No	Detecting Condition	Possible Cause
C1201 (FL) C1204 (FR) C1207 (RL) C1210 (RR)	<p>Detecting Condition for Speed Jump: This monitoring is performed for the period that the velocity of each wheel exceeds 2km/h.</p> <ol style="list-style-type: none"> 1. Controller counts the number of the wheel acceleration of 100g [(25km/h) for 7ms]. When the numbers at one wheel exceed 56 times, or When the numbers at more two wheels exceed 5 times, controller recognize the failure. 2. Controller counts the number of the wheel acceleration of 40g [(10km/h) for 7ms]. When the numbers at one wheel exceed 126 times, or When the numbers at more two wheels exceed 20 times, controller recognize the failure. 3. Controller counts the number of the wheel deceleration of -100g[(-25km/h) for 7ms]. When the numbers at each wheel exceed 56 times, controller recognize the failure. 4. The wheel deceleration of -100g[(-25km/h) for 7ms] causes the controller to start monitoring this failure and to compare the wheel velocity with the vehicle velocity from next cycle. When its difference of -100g is continued for more than 140msec, controller recognize the failure. 	<ul style="list-style-type: none"> - Improper installation of wheel speed sensor - An open or short in the wire - Faulty wheel speed sensor - Faulty rotor or wheel bearing - Faulty HECU

5. In case that any sensor failure at other wheel was already detected, When the numbers of 100g at each wheel exceed 5 times, or When the numbers of 40g at each wheel exceed 20 times, controller recognize the failure.

Ebay User ID: reveleus1

Detecting Condition for Damaged Exciter:

1. Max. wheel velocity exceeds 20km/h and the wheel velocity is 40% of max. wheel velocity. if this condition is lasted for 2 minutes.
2. Max. wheel velocity exceeds 40km/h and the wheel velocity is 60% of max. wheel velocity. if this condition is lasted for 2 minutes.

FAILSAFE FUNCTION

Sensor failure outside the ABS control cycle:

1. Only one wheel failure

Only the ABS(,TCS) function is inhibited. the ABS(,TCS) warning lamp is activated and the EBD warning lamp not activated.

2. More than two wheels failure

System down. both the ABS(,TCS) and the EBD function are inhibited and the ABS(,TCS) and the EBD warning lamps is activated. In this failure, the valve relay and all solenoids are prevented from being switched on.

Sensor failure inside the ABS control cycle:

1. One front wheel failure

Inhibit the ABS control of the failed-wheel and maintain the ABS control of normal wheel.

After the controller completes the ABS control, the ABS(,TCS) function is inhibited. the ABS(,TCS) warning lamp is activated and the EBD warning lamp not activated.

2. One rear wheel failure

Inhibit ABS control of both front wheels and the pressure of both rear wheels is decreased.

After the controller completes the ABS control, Only the ABS(,TCS) function is inhibited. the ABS(,TCS) warning lamp is activated and the EBD warning lamp not activated.

3. More than two wheels failure.

System down. both the ABS(,TCS) and the EBD function are inhibited and the ABS(,TCS) and the EBD warning lamps is activated. In this failure, the valve relay and all solenoids are prevented from being switched on.

INSPECTION PROCEDURES

1 . CHECK WHEEL SPEED SENSOR

1. Disconnect the wheel speed sensor connector (2P).
 2. Measure the resistance between terminals 1 and 2 of the wheel speed sensor connector.
- **Specification: 1,275~1,495 Ω**
3. Measure the resistance between terminals 1 and 2 of the wheel speed sensor connector and body ground.
- **Specification: 1M Ω or higher**

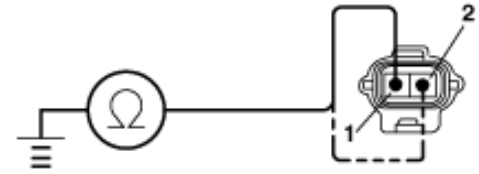
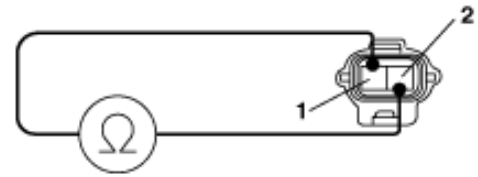

Is the resistance within specification?

Yes

No

Replace the wheel speed sensor.

2 . CHECK FOR OPEN AND SHORT CIRCUIT

Check for open and short circuit in the harness and connector between each wheel speed sensor and ABS control module.

OK

NG

Repair or replace harness or connector.

3 . CHECK WHEEL SPEED SENSOR INSTALLATION

Visually check for appropriate wheel speed sensor and rotor installation.

Note)

The mounting bolt shall be tightened properly and there is no clearance is allowed between the sensor and front steering knuckle or rear axle carrier.



OK

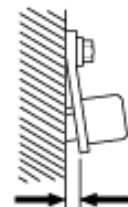

NG

OK

NG

Repair or replace the wheel speed sensor.

4 . CHECK WHEEL SPEED SENSOR AND SENSOR ROTOR

1. Disconnect the connector from the ABS control module.
2. Rotate the wheel to be measured approximately 1/2 to 1 rotation per second, and check the output voltage and the signal waveform using oscilloscope.

• **Specification: 130mVp-p or more.**

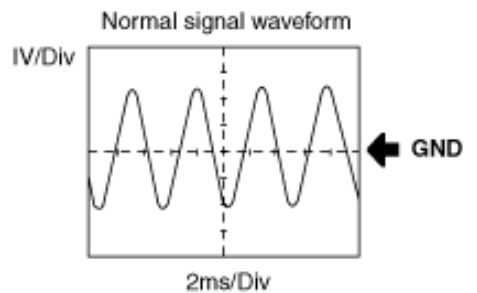

NG

OK	Check and replace the ABS control module.
----	---

5 . CHECK SENSOR ROTOR AND SENSOR TIP

1. Remove the front drive shaft and the rear axle hub.
2. Check the sensor rotor serrations.
Check if there are no scratches, missing teeth or foreign objects.
3. Remove the front and rear wheel speed sensors.
4. Check if there are no scratches or foreign objects on the sensor tip.

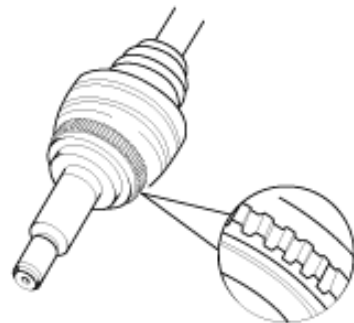

OK

NG	Replace the sensor rotor or wheel speed sensor.
----	---

Erase the DTC, and test-drive the vehicle.
If the ABS warning lamp comes on and the same DTC is indicated, replace the ABS control module.

DTC	C1202 (FL) C1205 (FR) C1208 (RL) C1211 (RR)	Wheel Speed Sensor Signal Malfunction (Air-gap error or wrong excite)
-----	--	---

DTC DETECTING CONDITION

DTC No	Detecting Condition	Possible Cause
--------	---------------------	----------------

Detecting Condition for Large Air-Gap:

This monitoring is performed for the period that the minimum velocity rises from 2km/h to 10km/h.

1. When the minimum wheel velocity is 2km/h and the velocity of other wheels exceed 10km/h with the acceleration of < 0.4g, the controller start comparing the velocity of other wheels except the min. wheel. if their difference below 4km/h is continued for 140msec, Otherwise, if their difference beyond 4km/h or > 0.4g is continued for 2 minutes.
2. In < 0.4g, when the velocity of more two wheels is 2km/h and the max. wheel velocity exceeds 10km/h, the condition is continued for 20 sec. Otherwise, In >0.4g, the condition is 2 minutes.
3. After velocity of 4 wheel exceeds 10km/h, when velocity of 1 wheel or 2 wheel is 2km/h and difference of other 2 wheel velocity is less than 4km/h under that those velocity is more than 10km/h, if that conditions are continued for 12 seconds.

Detecting Condition for Long Term ABS mode:

1. During the ABS control cycle, if the wheel velocity of 2km/h is lasted for more than 12sec.
2. If the ABS control cycle is continued for more than 36sec.

C1202 (FL)
C1205 (FR)
C1208 (RL)
C1211 (RR)

- Improper installation of wheel speed sensor
- An open or short in the wire
- Faulty wheel speed sensor
- Faulty rotor or wheel bearing
- Faulty HECU

FAILSAFE FUNCTION

Sensor failure outside the ABS control cycle:

1. Only one wheel failure
Only the ABS(,TCS) function is inhibited. the ABS(,TCS) warning lamp is activated and the EBD warning lamp not activated.
2. More than two wheels failure
System down. both the ABS(,TCS) and the EBD function are inhibited and the ABS(,TCS) and the EBD warning lamps is activated. In this failure, the valve relay and all solenoids are prevented from being switched on.

Sensor failure inside the ABS control cycle:

1. One front wheel failure
Inhibit the ABS control of the failed-wheel and maintain the ABS control of normal wheel.
After the controller completes the ABS control, the ABS(,TCS) function is inhibited. the ABS(,TCS) warning lamp is activated and the EBD warning lamp not activated.
2. One rear wheel failure
Inhibit ABS control of both front wheels and the pressure of both rear wheels is decreased.
After the controller completes the ABS control, Only the ABS(,TCS) function is inhibited. the ABS(,TCS) warning lamp is activated and the EBD warning lamp not activated.
3. More than two wheels failure.
System down. both the ABS(,TCS) and the EBD function are inhibited and the ABS(,TCS) and the EBD warning lamps is activated. In this failure, the valve relay and all solenoids are prevented from being switched on.

INSPECTION PROCEDURES

1. CHECK WHEEL SPEED SENSOR INSTALLATION

Visually check for appropriate wheel speed sensor and rotor installation (see table).

DTC	Appropriate wheel sensor
C1202	Front - left wheel sensor
C1205	Front - right wheel sensor
C1208	Rear- left wheel sensor
C1211	Rear- right wheel sensor



OK

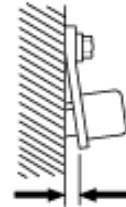

NG

Are they installed correctly?

Yes

No

Reinstall or replace the appropriate wheel speed sensor.

2. CHECK AIR GAP BETWEEN WHEEL SPEED SENSOR AND TONE WHEEL.

• **Specification**

- Front: 0.2~1.3 mm
- Rear: 0.2~1.3 mm

Is the air gap within specification?

Yes

No

Reinstall or replace the appropriate wheel speed sensor.

3. CHECK THE RESISTANCE BETWEEN TERMINALS OF HECU.

1. Disconnect the ABS control module connector (E37).
2. Measure the resistance between the appropriate wheel speed sensor(+) and (-) circuit terminals (see table).

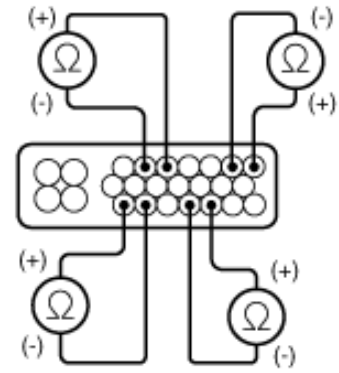

DTC	Appropriate Terminal	
	(+) side	(-) side
C1202 (Front - left)	1	2
C1205 (Front - right)	19	20
C1208 (Rear - left)	5	6
C1211 (Rear - right)	23	22

Is the resistance within 1,275~1,495Ω ?

Yes

No Repair an open or short in the wire between the ABS control module and the wheel speed sensor.

Erase the DTC, and test-drive the vehicle.
If the ABS warning lamp comes on and the same DTC is indicated, replace the ABS control module.

DTC	C1604	ECU Hardware Failure (ECU Internal or Solenoid Valve Failure)
-----	-------	--

DESCRIPTION

The HECU always monitors the solenoid valve drive circuit. It determines that there is an open or short-circuit in the solenoid coil or in a harness even if no current flows in the solenoid or through the HECU.

DTC DETECTING CONDITION

DTC No	Detecting Condition	Possible Cause
C1604	<p>Detecting Condition for Solenoid Valve Open or Short:</p> <ol style="list-style-type: none"> 1. When the valve relay is switched off, the drain voltage of the solenoid drive MOSFET is over the criterion, which is continued for 56msec. 2. When the valve relay is switched on and a solenoid off, the drain voltage of the solenoid drive MOSFET is under the criterion, which is continued for 56msec. 3. When the valve relay and a solenoid are switched on, the drain voltage of the solenoid drive MOSFET is over the criterion, which is continued for 56msec. <p>Detecting Condition for EEPROM Failure of ECU: When the MCU can't erase or write a data of the EEPROM.</p>	<ul style="list-style-type: none"> -An open or short in the solenoid valve circuit. -Leakage current in the solenoid valve. -Faulty HECU.

Detecting Condition for MCU Failure of ECU:

Ebay User ID: reveleus1

If the master/slave processor detects abnormal operation in RAM, status register, interrupt, timer, A/D converter and cycle time.

FAILSAFE FUNCTION

System down. both the ABS(,TCS) and the EBD function are inhibited and the ABS(,TCS) and the EBD warning lamps is activated. In this failure, the valve relay and all solenoids are prevented from being switched on.

INSPECTION PROCEDURES

1 . CHECK THE DTC ONCE MORE

1. Clear the DTC using the Hi-scan (Pro).
2. Turn the ignition switch OFF.
3. Turn the ignition switch ON, and check if the same DTC is stored in the memory.

Yes

No

Problem is intermittent and the ABS control module memory was not cleared.

2 . CHECK VOLTAGE BETWEEN TERMINALS OF HECU CONNECTOR

1. Disconnect the connector from the ABS control module.
2. Turn the ignition switch ON.
3. Measure the voltage between terminals 4 and 8, 24 of ABS control module harness side connector.

- **Specification: approximately B+**

Is the voltage within specification?

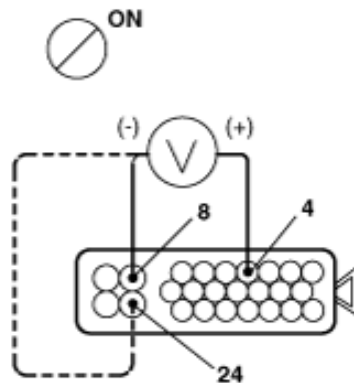

Yes

NO

Check for open or short in the wire.

3 . CHECK CONNECTION OF HECU

Check the connection of ABS control module connector

OK

NG

Repair or replace harness or connector.

Check and replace the ABS control module.

DTC	C2112	Valve Relay Failure (Valve Relay or Fuse Failure)
------------	--------------	--

DESCRIPTION

When the ignition switch is turned ON, the HECU switches the valve relay on and off during its initial check. During this time, voltage sent to the valve relay is compared to the voltage in the valve power monitor line. If no current is detected in the valve power monitor line, the HECU determines that there is an open circuit and DTC C2112 is recorded.

DTC DETECTING CONDITION

DTC No	Detecting Condition	Possible Cause
C2112	<p>Detecting Condition for Valve Relay Open: When the valve relay is switched on, the reference voltage of valve relay is under the permitted range, which is continued for 56msec.</p> <p>Detecting Condition for Valve Relay Short: When the valve relay is switched off, the reference voltage of valve relay is over the criterion, which is continued for 56msec.</p>	<p>-An open or short in the valve relay circuit.</p> <p>-Faulty HECU</p>

FAILSAFE FUNCTION

System down. both the ABS(,TCS) and the EBD function are inhibited and the ABS(,TCS) and the EBD warning lamps is activated. In this failure, the valve relay and all solenoids are prevented from being switched on.

INSPECTION PROCEDURES**1 . CHECK THE DTC ONCE MORE**

1. Clear the DTC using the Hi-scan (Pro).
2. Turn the ignition switch OFF.
3. Turn the ignition switch ON, and check if the same DTC is stored in the memory.

Yes

No

Problem is intermittent and the ABS control module memory was not cleared.

2 . CHECK THE POWER SOURCE OF VALVE RELAY

1. Disconnect the connector from the ABS control module.
2. Measure the voltage between the terminals 25 and 8, 24 of the ABS control module harness side connector.

- **Specification: approximately B+**

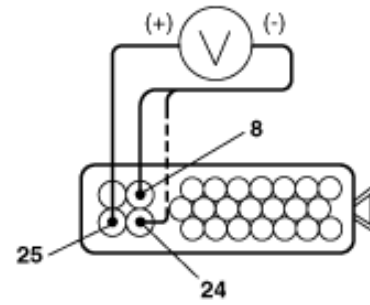

Is the voltage within specification?



NO

Check and replace fuse (10A) and fusible link (30A).
Check and repair harness or connector.

If the same code is still output after the DTC is deleted, check the contact condition of each connection.
If the connections are normal, the ABS control module may be defective.

DTC	C2402	Motor Relay or Motor Electrical Failure
------------	--------------	--

DESCRIPTION

The ABS motor relay supplies power to the ABS pump motor. While the ABS is activated, the HECU switches the ABS motor relay ON and operates the ABS pump motor.

DTC DETECTING CONDITION

DTC No	Detecting Condition	Possible Cause
C2402	<p>Detecting Condition for Motor Relay Open or Motor Short to Battery: When the motor relay is switched on, the reference voltage of motor is over the criterion, which is continued for 49msec.</p> <p>Detecting Condition for Motor Lock: The controller starts monitoring the motor voltage for 84msec from the time when the motor relay is switched off. if the motor voltage is over the criterion for 49msec after shutting off the motor, the motor is reactivated for 500msec after shutting off the motor 84msec and the above check is performed again for a maximum of two times. When the motor voltage is not normal even on the second check, the controller recognizes it as failure.</p> <p>Detecting Condition for Fuse Open, Motor Open or Short to Ground: The controller starts monitoring the motor after 1.8sec from the time when the motor relay is switched off. if the motor voltage is under the criterion for 0.2 sec.</p>	<p>-An open or short in the motor relay or motor circuit.</p> <p>-Motor lock</p> <p>-Faulty HECU.</p>

FAILSAFE FUNCTION

1. Only the ABS(,TCS) function is inhibited. the ABS(,TCS) warning lamp is activated and the EBD warning lamp not activated.
2. Motor error during the ABS control cycle : inhibit the ABS control of front wheels, allow ABS control of the rear wheels, and ABS(,TCS) warning lamp is switched ON at the end of ABS control.

INSPECTION PROCEDURES

1. TEST MOTOR ACTUATION USING HI-SCAN (PRO).

Is the operating sound of motor heard?



Yes Check the harness and repair if necessary.

2. CHECK THE POWER SOURCE OF MOTOR.

1. Disconnect the connector from the ABS control module.
2. Measure the voltage between the terminals 9 and 8, 24 of the ABS control module harness side connector.

- **Specification: approximately B+**

Is the voltage within specification?

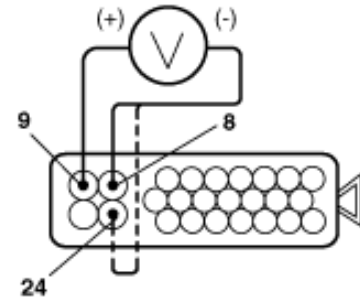

No Check and replace fuses.
Check and repair harness or connector.

If the same code is still output after the DTC is deleted, check the contact condition of each connection.
If the connections are normal, the ABS control module may be defective.

DTC	C1503	TCS Switch Failure (only System with TCS)
------------	--------------	--

DESCRIPTION

When the TCS switch is pressed, TCS control is deactivated and the TCS OFF indicator lights up.
The TCS OFF indicator turns "ON" when the HECU prohibit TCS controls.

DTC DETECTING CONDITION

DTC No	Detecting Condition	Possible Cause
C1503	The condition that the level of TCS switch is high is continued for 60 sec.	-An open or short in the TCS switch circuit. -Faulty TCS switch -Faulty HECU.

Inhibit the TCS control and allow the ABS/EBD control.
 Meanwhile, stop checking the TCS switch failure under the TCS control.

INSPECTION PROCEDURES

1. CHECK THE DTC ONCE MORE.

1. Clear the DTC using hi-scan (pro).
2. Turn the ignition switch OFF.
3. Turn the ignition switch ON, and check if the same DTC is stored in the memory.

Yes

No Problem is intermittent and the ABS control module memory was not cleared.

2. CHECK THE TCS SWITCH.

1. Remove the TCS switch.
2. Check for continuity between the terminals while operating the TCS switch.

Is there continuity between terminals 5 and 6 of TCS switch side connector (I47) with TCS switch ON?

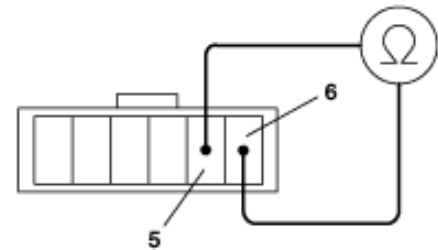

Terminal Position	1	2	5	6
ON				
OFF				

Yes

No Replace the TCS switch with new one and recheck.

3. CHECK THE POWER SUPPLY CIRCUIT.

1. Disconnect the connector from the TCS switch.
2. Turn the ignition switch ON.
3. Measure the power supply voltage between terminal 6 of TCS switch harness side connector (I47) and body ground.

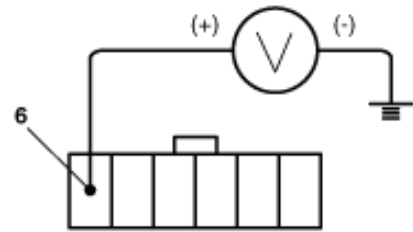

• **Specification: approximately B+**

Is the voltage within specification?

Yes

No

Check and replace No.10 fuse (10A).
Check and repair harness or connector.

4. CHECK FOR OPEN IN THE WIRE.

Check for continuity in the wire between terminal 5 of TCS switch harness side connector (I47) and terminal 14 of HECU harness side connector (E37).

Is there continuity?

Yes

No

Check and repair harness or connector.

Erase the DTC, and test-drive the vehicle.
If the same DTC is indicated, replace the ABS control module.

DTC	C1605	CAN Hardware Failure (only System with TCS)
------------	--------------	--

DESCRIPTION

The CAN circuit is used to send TCS control information from the HECU to the engine ECM and TCM, and engine and transmission control information from the engine ECM and TCM to the HECU.

DTC DETECTING CONDITION

DTC No	Detecting Condition	Possible Cause
C1605	In case that CAN has hardware failure.	-Faulty CAN or bus

FAILSAFE FUNCTION

Inhibit the TCS control and allow the ABS/EBD control.

Purchased
from Ebay seller
Reveleus1

Thank-you for purchasing from me, it
is much appreciated.

To contact me please email
suzlever@gmail.com

DTC	C1610	CAN Bus Off Failure (only System with TCS)
-----	-------	---

DESCRIPTION

The CAN circuit is used to send TCS control information from the HECU to the engine ECM and TCM, and engine and transmission control information from the engine ECM and TCM to the HECU.

DTC DETECTING CONDITION

DTC No	Detecting Condition	Possible Cause
C1610	In case CAN BUS off state continued for more than 0.1sec.	-An open or short in the CAN bus circuit. -Faulty CAN bus -Faulty HECU

FAILSAFE FUNCTION

Inhibit the TCS control and allow the ABS/EBD control.

INSPECTION PROCEDURES

1. CHECK FOR OPEN IN THE CAN LINE.

1. Check for continuity in the wire between terminal 10 of HECU harness side connector (E37) and terminal 6 of PCM harness side connector (C183-1).
2. Check for continuity in the wire between terminal 11 of HECU harness side connector (E37) and terminal 7 of PCM harness side connector (C183-1).

Is there continuity?



No	Check and repair harness or connector.
----	--

Check the PCM according to the instructions of engine or T/M group.

DTC	C1611	EMS Time-out Failure (only System with TCS)
-----	-------	--

DESCRIPTION

HECU will compare signals from front (driving) and rear wheel speed sensors to detect driving wheels slip.

Upon detecting driving wheels slip, HECU will perform TCS control.

The HECU will transmit engine torque reduction request, fuel cut cylinder number, and TCS control request signals in accordance with slip level to engine ECM and TCM through BUS line which will provide CAN communication for TCS control.

Engine ECM will perform fuel cut as requested by HECU and retard ignition timing as per engine torque reduction request signal.

TCM will hold shift position by TCS control time according to TCS operation signal. Then enhanced acceleration by kick-down will not occur.

DTC DETECTING CONDITION

DTC No	Detecting Condition	Possible Cause
C1611	1. In case that EMS1 or EMS2 message was not received for more than 0.5 sec. within normal voltage condition. 2. The monitoring starts 2 sec. after power up.	-An open or short in the CAN bus circuit. -Faulty CAN bus -Faulty EMS -Faulty HECU

FAILSAFE FUNCTION

Inhibit the TCS control and allow the ABS/EBD control.

INSPECTION PROCEDURES

1. CHECK FOR OPEN IN THE CAN LINE.

1. Check for continuity in the wire between terminal 10 of HECU harness side connector (E37) and terminal 6 of PCM harness side connector (C183-1).
2. Check for continuity in the wire between terminal 11 of HECU harness side connector (E37) and terminal 7 of PCM harness side connector (C183-1).

Is there continuity?



Yes

No

Check and repair harness or connector.

Check the PCM according to the instructions of engine or T/M group.

DTC	C1612	TCM Time-out Failure (only System with TCS)
-----	-------	---

DESCRIPTION

HECU will compare signals from front (driving) and rear wheel speed sensors to detect driving wheels slip.

Upon detecting driving wheels slip, HECU will perform TCS control.

The HECU will transmit engine torque reduction request, fuel cut cylinder number, and TCS control request signals in accordance with slip level to engine ECM and TCM through BUS line which will provide CAN communication for TCS control.

Engine ECM will perform fuel cut as requested by HECU and retard ignition timing as per engine torque reduction request signal.

TCM will hold shift position by TCS control time according to TCS operation signal. Then enhanced acceleration by kick-down will not occur.

DTC DETECTING CONDITION

DTC No	Detecting Condition	Possible Cause
C1612	1. In case that TCM message was not received for more than 0.5 sec. within normal voltage condition. 2. The monitoring starts 2 sec. after power up.	-An open or short in the CAN bus circuit. -Faulty CAN bus -Faulty TCM -Faulty HECU

FAILSAFE FUNCTION

Inhibit the TCS control and allow the ABS/EBD control.

INSPECTION PROCEDURES

1. CHECK FOR OPEN IN THE CAN LINE.

1. Check for continuity in the wire between terminal 10 of HECU harness side connector (E37) and terminal 6 of PCM harness side connector (C183-1).
2. Check for continuity in the wire between terminal 11 of HECU harness side connector (E37) and terminal 7 of PCM harness side connector (C183-1).

Is there continuity?



No

Check and repair harness or connector.

Check the PCM according to the instructions of engine or T/M group.

DTC	C1613	TCM Wrong-Matched Transmission Failure (only System with TCS)
-----	-------	--

DESCRIPTION

HECU will compare signals from front (driving) and rear wheel speed sensors to detect driving wheels slip.

Upon detecting driving wheels slip, HECU will perform TCS control.

The HECU will transmit engine torque reduction request, fuel cut cylinder number, and TCS control request signals in accordance with slip level to engine ECM and TCM through BUS line which will provide CAN communication for TCS control.

Engine ECM will perform fuel cut as requested by HECU and retard ignition timing as per engine torque reduction request signal.

TCM will hold shift position by TCS control time according to TCS operation signal. Then enhanced acceleration by kick-down will not occur.

DTC DETECTING CONDITION

DTC No	Detecting Condition	Possible Cause
C1613	1. In case that the information about transmission is different in the EMS message and TCM message within normal voltage condition. 2. The monitoring starts 2 sec. after power up.	-Faulty CAN bus -Faulty EMS or TCM

FAILSAFE FUNCTION

Inhibit the TCS control and allow the ABS/EBD control.

DTC	C2227	Brake Disc Overheat (only System with TCS)
-----	-------	--

DESCRIPTION

On TCS control, brake control will be performed by motor pump output pressure.

This brake traction control cause the brake disc to overheat.

DTC DETECTING CONDITION

DTC No	Detecting Condition	Possible Cause
C2227	1. When the calculated temperature of disc is higher than predefined value. 2. If the calculated temperature reach to predefined value, the controller recovers to normal state.	-Brake disc is overheating

FAILSAFE FUNCTION

Inhibit the TCS control and allow the ABS/EBD control.



Operation and Leakage Check

Check all of the following items:

Component	Procedure
Brake Booster (A)	Check brake operation by applying the brakes during a test drive. If the brakes do not work properly, check the brake booster. Replace the brake booster as an assembly if it does not work properly or if there are signs of leakage.
Piston cup and pressure cup inspection (B)	<ul style="list-style-type: none"> •Check brake operation by applying the brakes. Look for damage or signs of fluid leakage. Replace the master cylinder as an assembly if the pedal does not work properly or if there is damage or signs of fluid leakage. •Check for a difference in brake pedal stroke between quick and slow brake applications. Replace the master cylinder if there is a difference in pedal stroke.
Brake hoses (C)	Look for damage or signs of fluid leakage. Replace the brake hose with a new one if it is damaged or leaking.
Caliper piston seal and piston boots (D)	<p>Check brake operation by applying the brakes.</p> <p>Look for damage or signs of fluid leakage. If the pedal does not work properly, the brakes drag, or there is damage or signs of fluid leakage, disassemble and inspect the brake caliper. Replace the boots and seals with new ones whenever the brake caliper is disassembled.</p>
Wheel cylinder piston cup and dust cover (E)	<p>Check brake operation by applying the brakes.</p> <p>Look for damage or signs of fluid leakage. If the pedal does not work properly, the brakes drag, or there is damage or signs of fluid leakage, replace the wheel cylinder.</p>

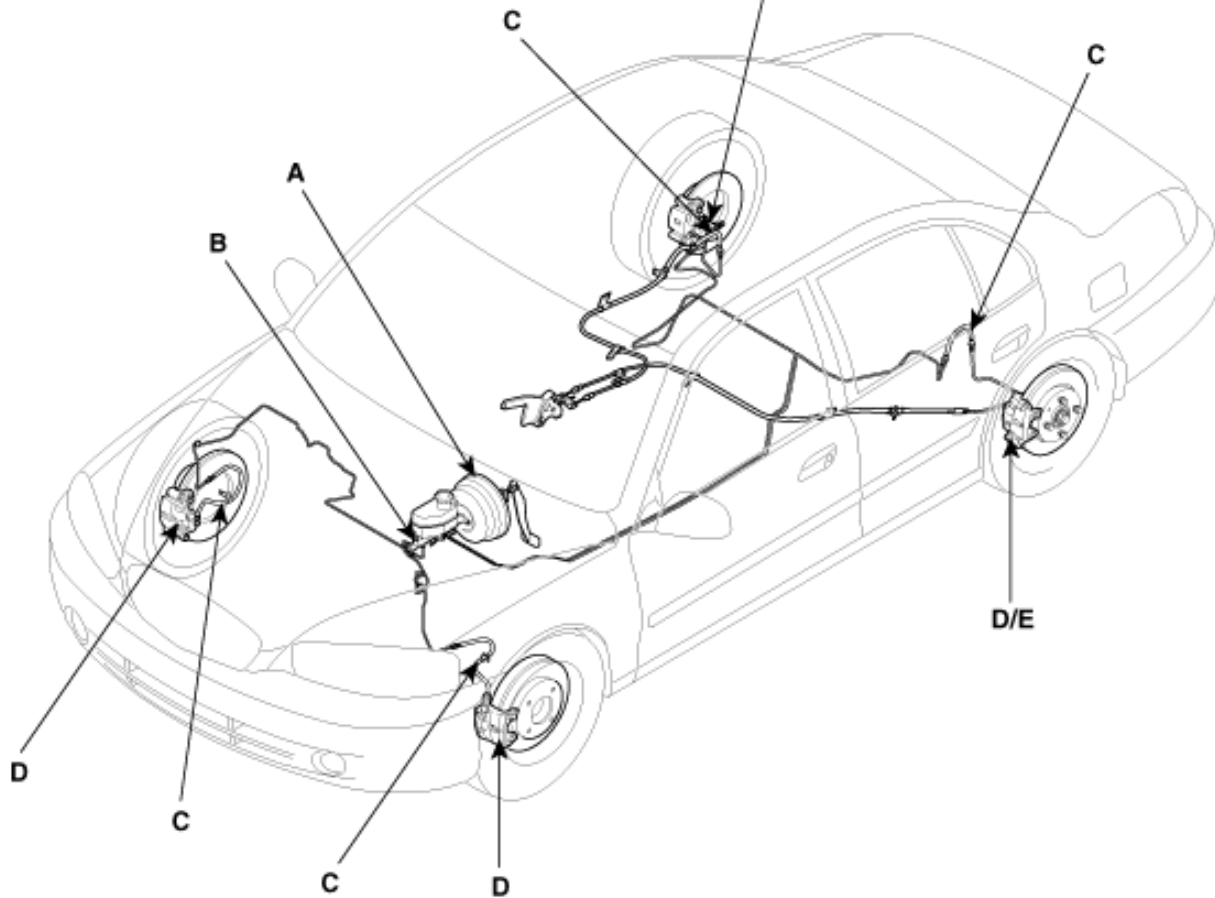

Operation and Leakage Check

Check all of the following items:

Component	Procedure
Brake Booster (A)	Check brake operation by applying the brakes during a test drive. If the brakes do not work properly, check the brake booster. Replace the brake booster as an assembly if it does not work properly or if there are signs of leakage.
Piston cup and pressure cup inspection (B)	<ul style="list-style-type: none"> •Check brake operation by applying the brakes. Look for damage or signs of fluid leakage. Replace the master cylinder as an assembly if the pedal does not work properly or if there is damage or signs of fluid leakage. •Check for a difference in brake pedal stroke between quick and slow brake applications. Replace the master cylinder if there is a difference in pedal stroke.
Brake hoses (C)	Look for damage or signs of fluid leakage. Replace the brake hose with a new one if it is damaged or leaking.
Caliper piston seal and piston boots (D)	Check brake operation by applying the brakes. Look for damage or signs of fluid leakage. If the pedal does not work properly, the brakes drag, or there is damage or signs of fluid leakage, disassemble and inspect the brake caliper. Replace the boots and seals with new ones whenever the brake caliper is disassembled.

Wheel cylinder piston cup
and dust cover (E)

Check brake operation by applying the brakes.

Look for damage or signs of fluid leakage. If the pedal does not work properly, the brakes drag, or there is damage or signs of fluid leakage, replace the wheel cylinder.

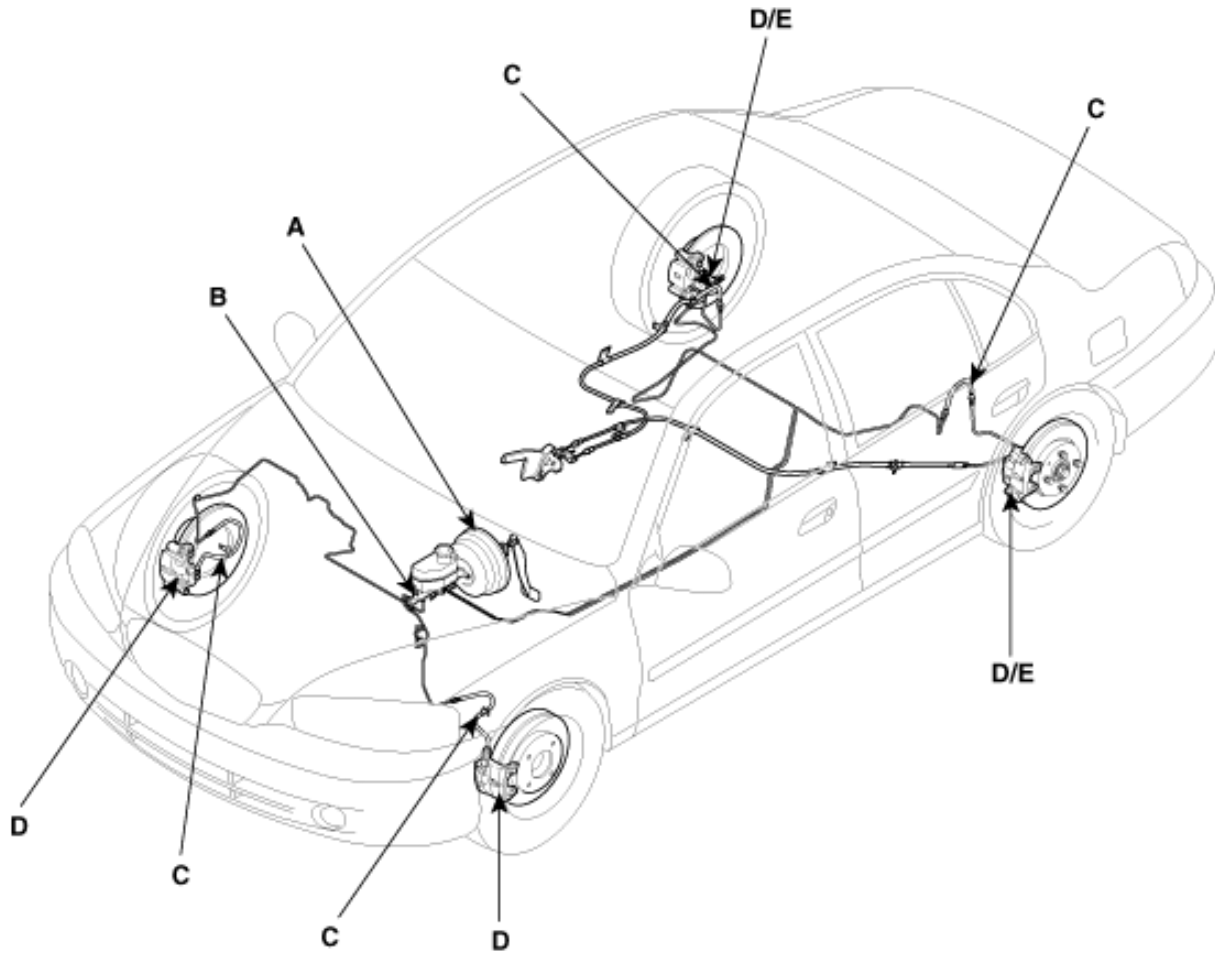

COMPONENTS

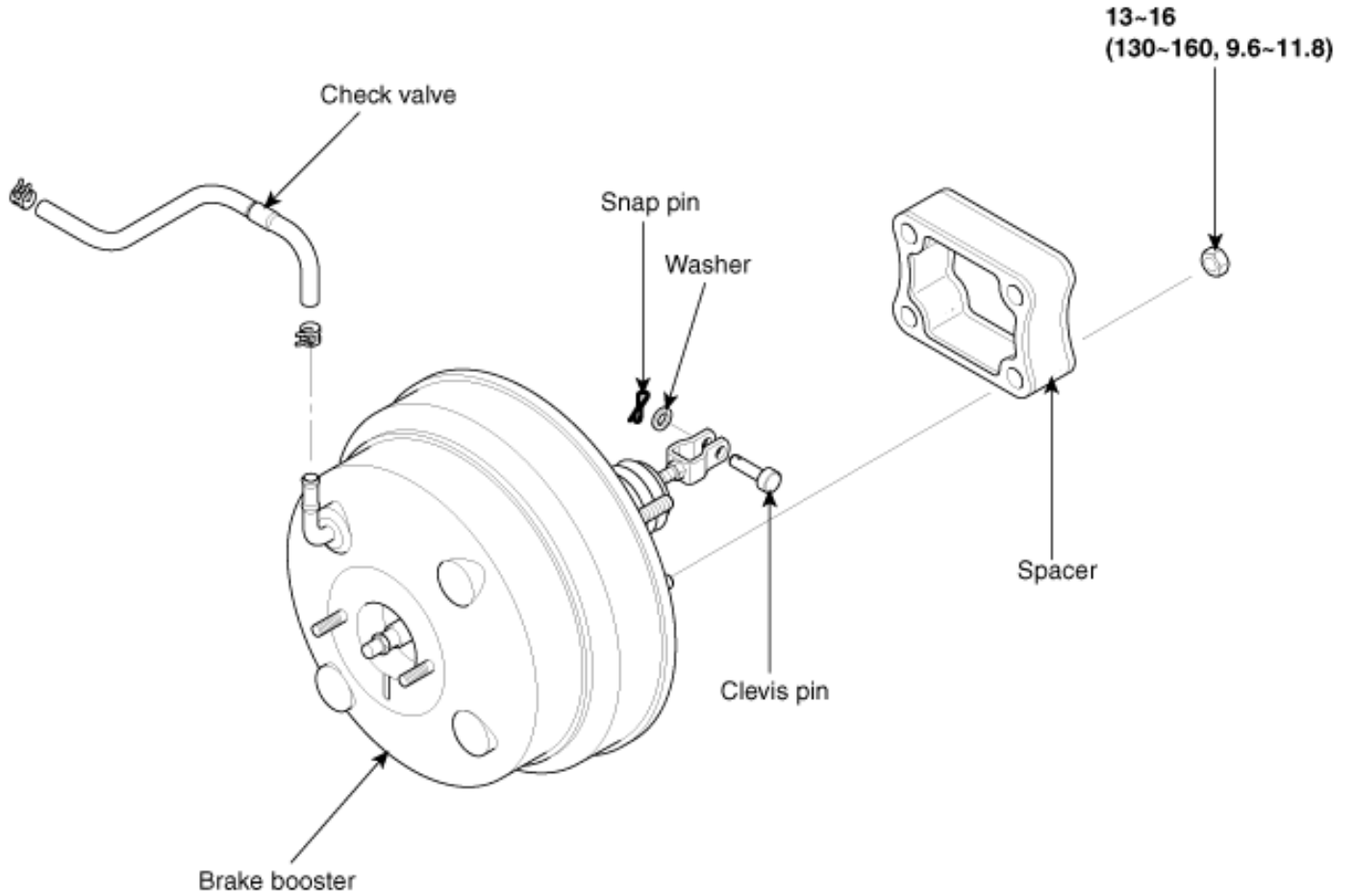

TORQUE: Nm (kgf-cm, lbf-ft)

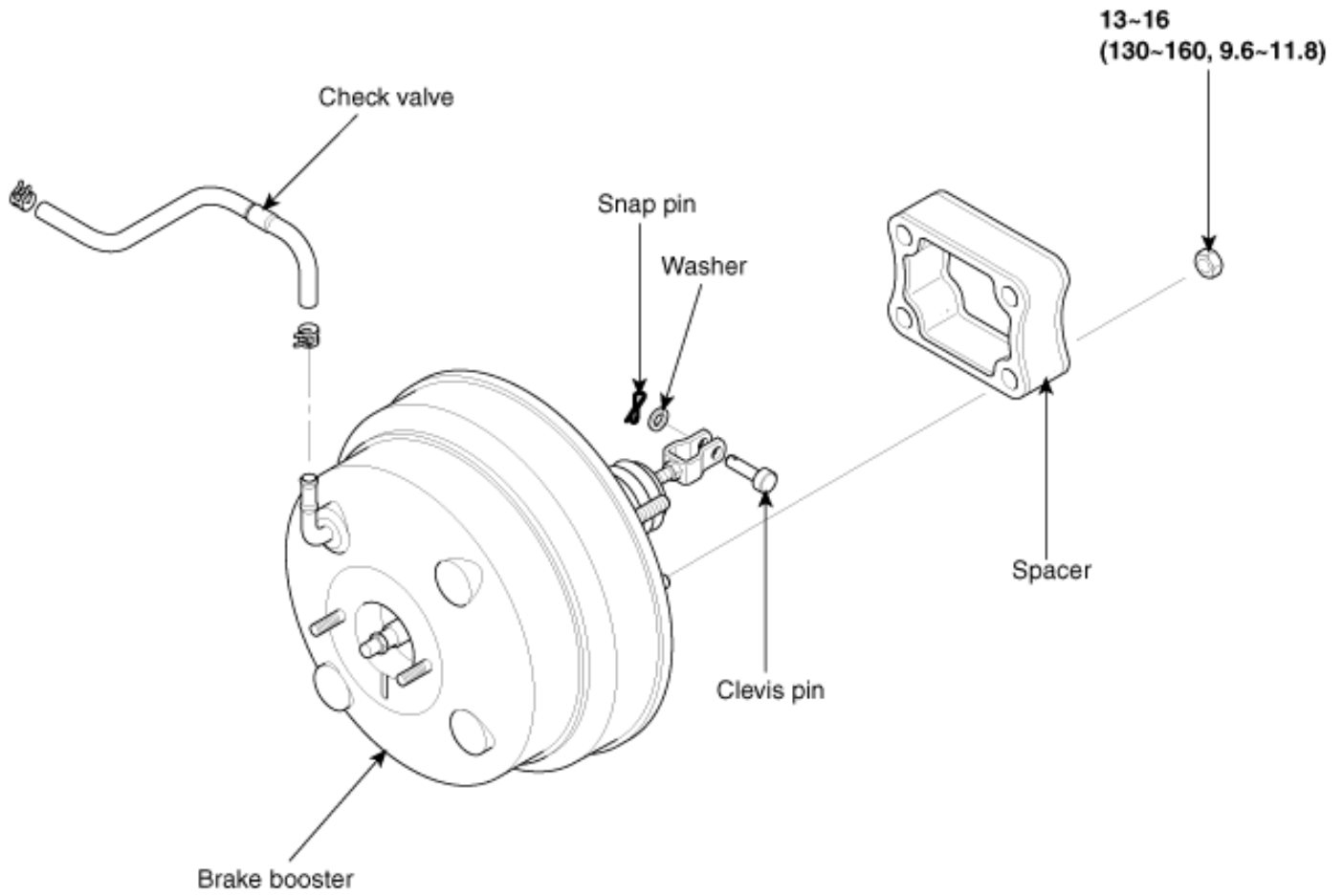

TORQUE: Nm (kgf-cm, lbf-ft)

REPLACEMENT

1. Remove the master cylinder (see page BR-20).
2. Disconnect the vacuum hose (A) from the brake booster (B).

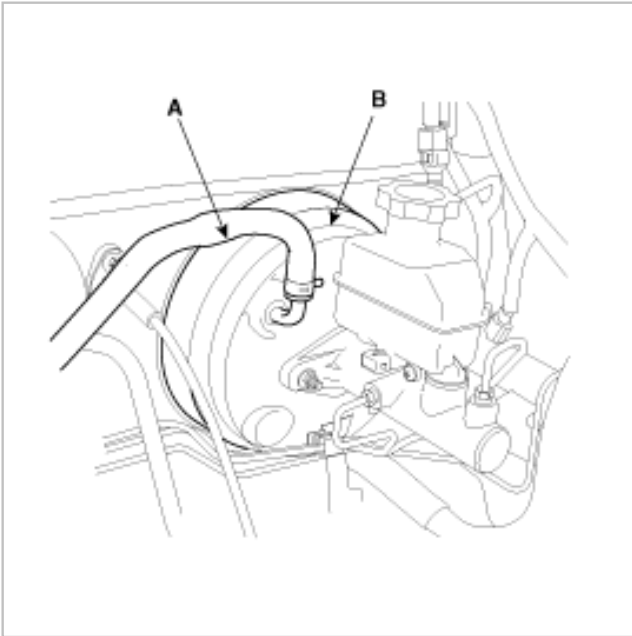

3. Remove the snap pin (A) clevis pin (B) and washer (C).

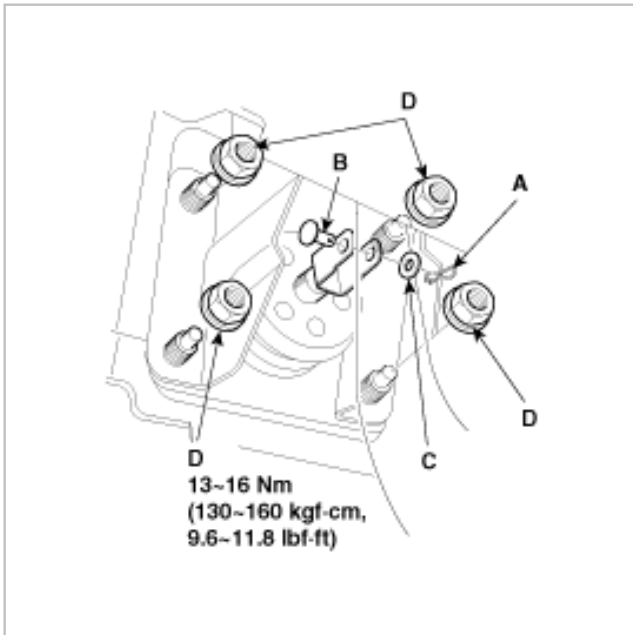

4. Remove the for booster mounting nuts (D).

5. Remove the brake booster (A) from the engine compartment.
Ebay User ID: reveleus1

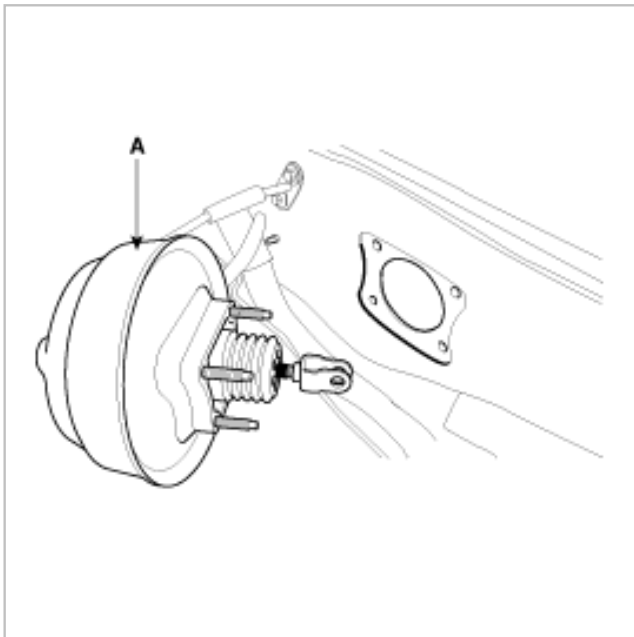

6. Install the brake booster in the reverse order of removal, and note these items:
- A. After installation, adjust brake pedal height and brake pedal free play (see page BR-9).
 - B. Use new snap pin and clevis pin whenever installing.
 - C. Apply grease to both sides of the snap pin and the clevis pin.

REPLACEMENT

1. Remove the master cylinder (see page BR-20).
2. Disconnect the vacuum hose (A) from the brake booster (B).

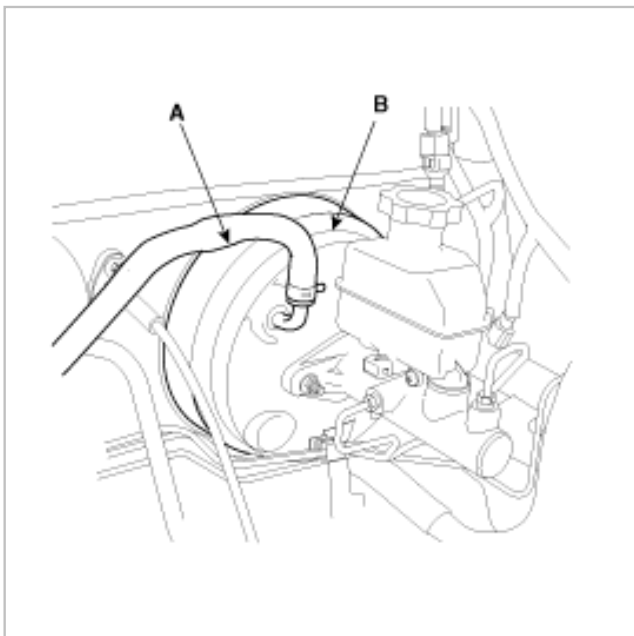

3. Remove the snap pin (A) clevis pin (B) and washer (C).
Ebay User ID: reveleus1

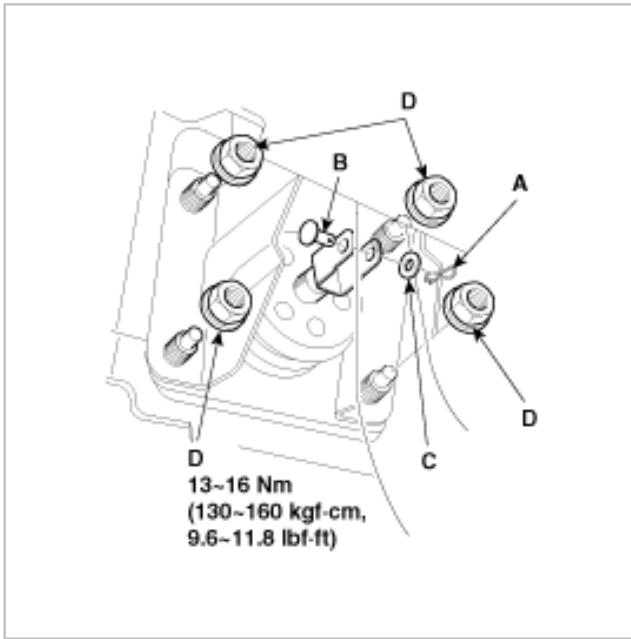

4. Remove the for booster mounting nuts (D).
5. Remove the brake booster (A) from the engine compartment.

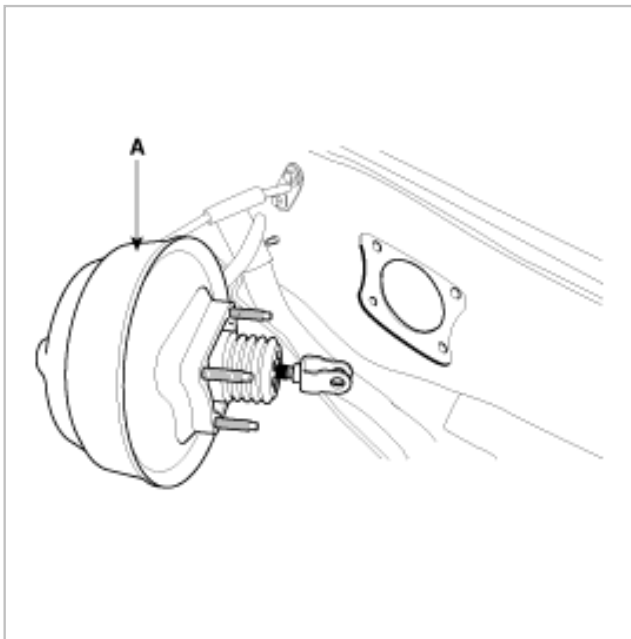

6. Install the brake booster in the reverse order of removal, and note these items:
 - A. After installation, adjust brake pedal height and brake pedal free play (see page BR-9).
 - B. Use new snap pin and clevis pin whenever installing.
 - C. Apply grease to both sides of the snap pin and the clevis pin.



TESTS

Functional test

1. With the engine stopped, depress the brake pedal several times to deplete the vacuum reservoir, then depress the pedal hard and hold it for 15 seconds. If the pedal sinks, either the master cylinder is bypassing internally, or the brake system (master cylinder, lines, proportioning valve, or caliper) is leaking.
2. Start the engine with the pedal depressed. If the pedal sinks slightly, the vacuum booster is operating normally. If the pedal height does not vary, the booster or check valve is faulty

Leak test

1. Depress the brake pedal with the engine running, then stop the engine. If the pedal height does not vary while depressed for 30 seconds, the vacuum booster is OK. If the pedal rises, the booster is faulty.
2. With the engine stopped, depress the brake pedal several times using normal pressure. When the pedal is first depressed, it should be low. On consecutive application, the pedal height should gradually rise. If the pedal position does not vary, check the booster check valve.

Check valve test

1. Disconnect the brake booster vacuum hose (check valve built in) (A) at the booster (B).

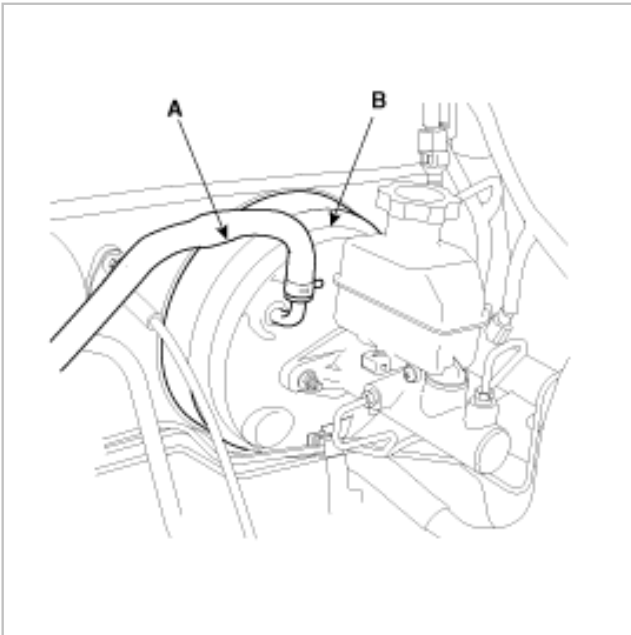

2. Start the engine and let it idle. There should be vacuum available. If no vacuum is available, the check valve is not working properly. Replace the brake booster vacuum hose and check valve and retest.

TESTS

Functional test

1. With the engine stopped, depress the brake pedal several times to deplete the vacuum reservoir, then depress the pedal hard and hold it for 15 seconds. If the pedal sinks, either the master cylinder is bypassing internally, or the brake system (master cylinder, lines, proportioning valve, or caliper) is leaking.
2. Start the engine with the pedal depressed. If the pedal sinks slightly, the vacuum booster is operating normally. If the pedal height does not vary, the booster or check valve is faulty

Leak test

Ebay User ID: reveleus1

1. Depress the brake pedal with the engine running, then stop the engine. If the pedal height does not vary while depressed for 30 seconds, the vacuum booster is OK. If the pedal rises, the booster is faulty.
2. With the engine stopped, depress the brake pedal several times using normal pressure. When the pedal is first depressed, it should be low. On consecutive application, the pedal height should gradually rise. If the pedal position does not vary, check the booster check valve.

Check valve test

1. Disconnect the brake booster vacuum hose (check valve built in) (A) at the booster (B).

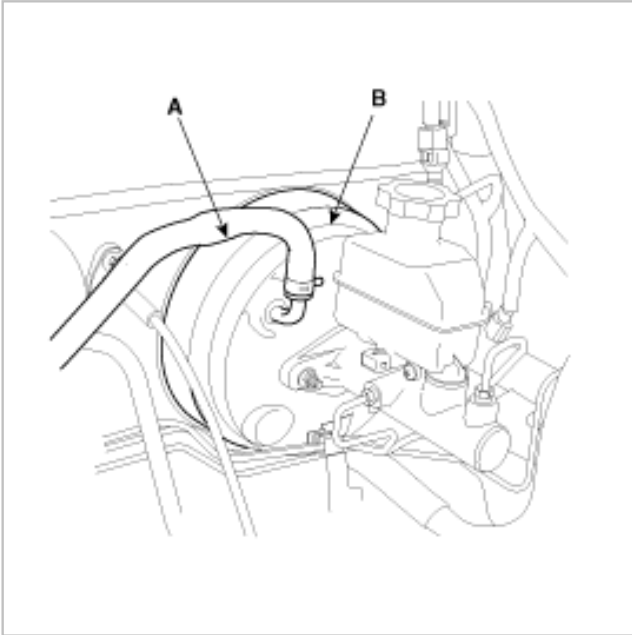

2. Start the engine and let it idle. There should be vacuum available. If no vacuum is available, the check valve is not working properly. Replace the brake booster vacuum hose and check valve and retest.

Component Location

Disc brake:

Brake hose to caliper 25~30 (250~300, 18.4~22.1)

Bleed screw 7~9 (70~90, 5.2~6.6)

Drum brake:

Brake line to wheel cylinder 13~17 (130~170, 9.6~12.5)

Bleed screw 7~13 (70~130, 5.2~9.6)

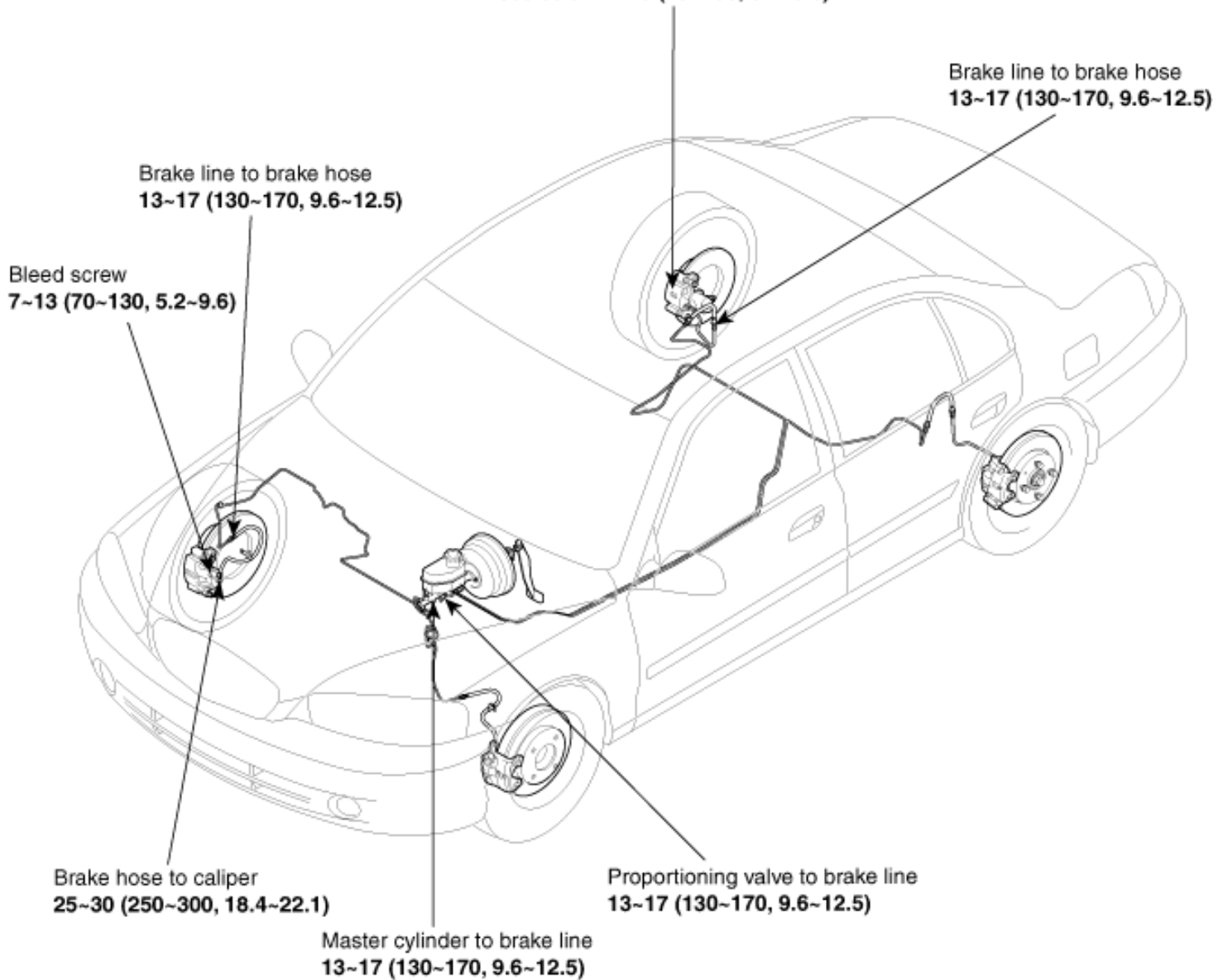

TORQUE: Nm (kgf-cm, lbf-ft)

Disc brake:

Brake hose to caliper 25~30 (250~300, 18.4~22.1)

Bleed screw 7~9 (70~90, 5.2~6.6)

Drum brake:

Brake line to wheel cylinder 13~17 (130~170, 9.6~12.5)

Bleed screw 7~13 (70~130, 5.2~9.6)

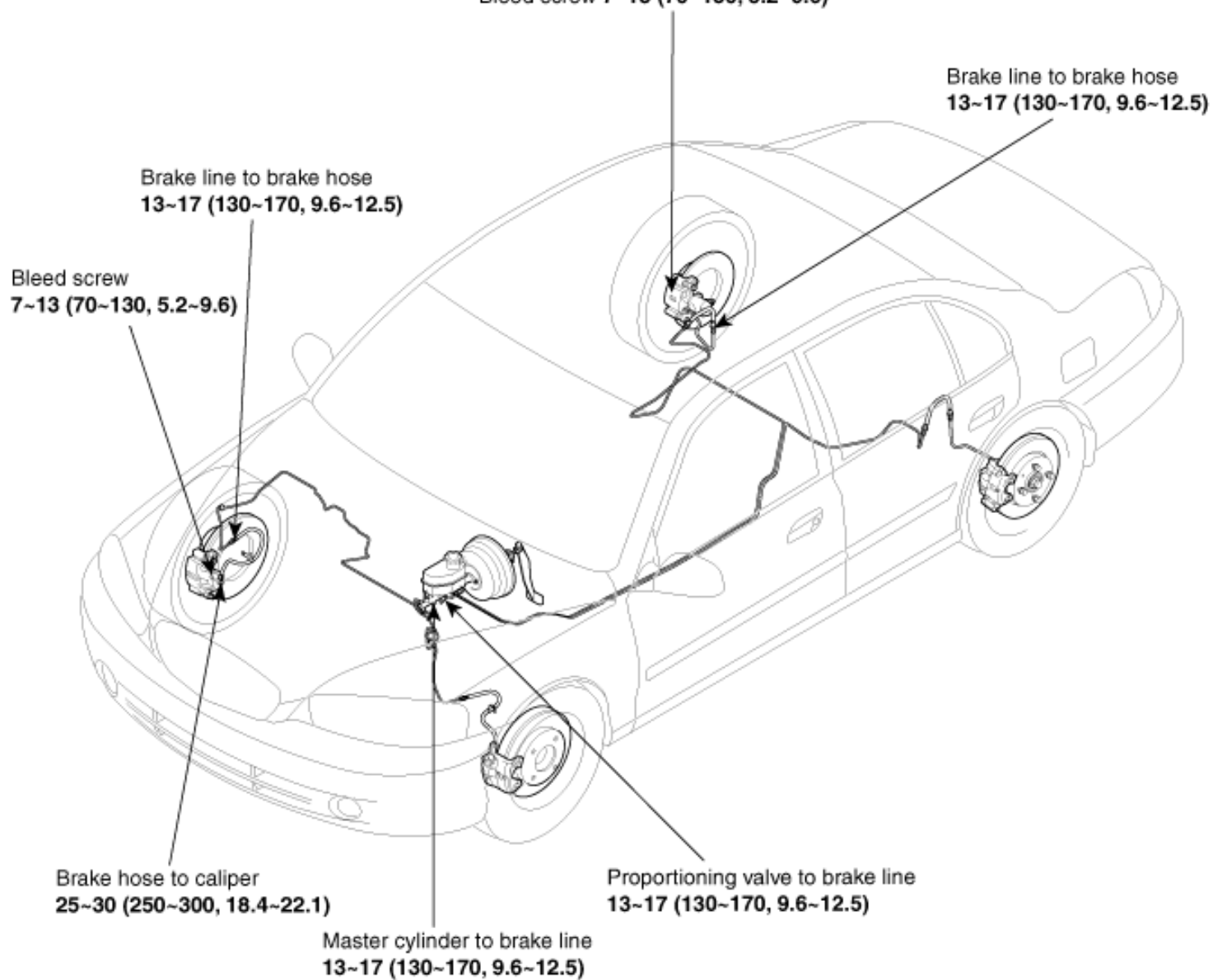

TORQUE: Nm (kgf-cm, lbf-ft)

Inspection

1. Inspect the brake hoses, for damage, deterioration, leaks, interference and twisting.
2. Check the brake lines for damage, rusting, and leakage. Also check for bent brake lines.
3. Check for leaks at hose and line joints or connections, and retighten if necessary.
4. Check the master cylinder for damage and leakage.

NOTE

Replace the brake hose clip whenever the brake hose is serviced.

Replacement

NOTE

- Before reassembling, check that all parts are free of dust and other foreign particles.
- Replace parts with new ones whenever specified to do so.
- Do not spill brake fluid on the vehicle; it may damage the paint; if brake fluid gets on the paint, wash it off immediately with water.

1. Replace the brake hose (A) if the hose is twisted, cracked, or if it leaks.

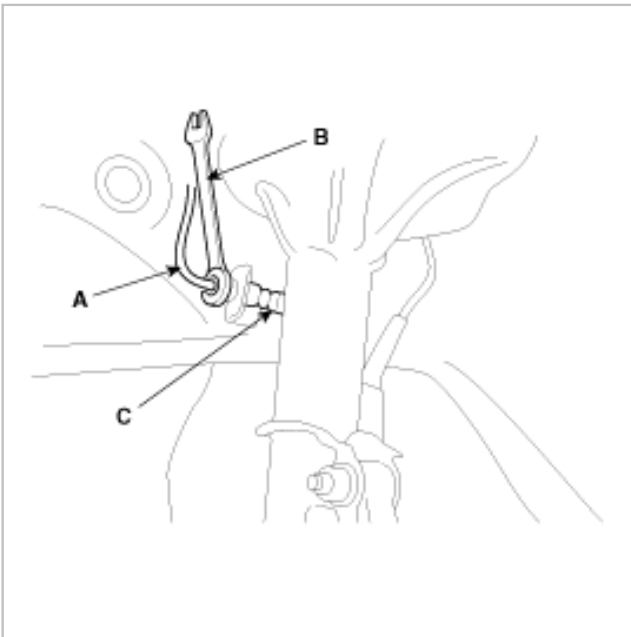

2. Disconnect the brake hose from the brake line (B) using a 10mm flare-nut wrench (C).

3. Remove and discard the brake hose clip (A) from the brake hose (B).
Ebay User ID: reveleus1

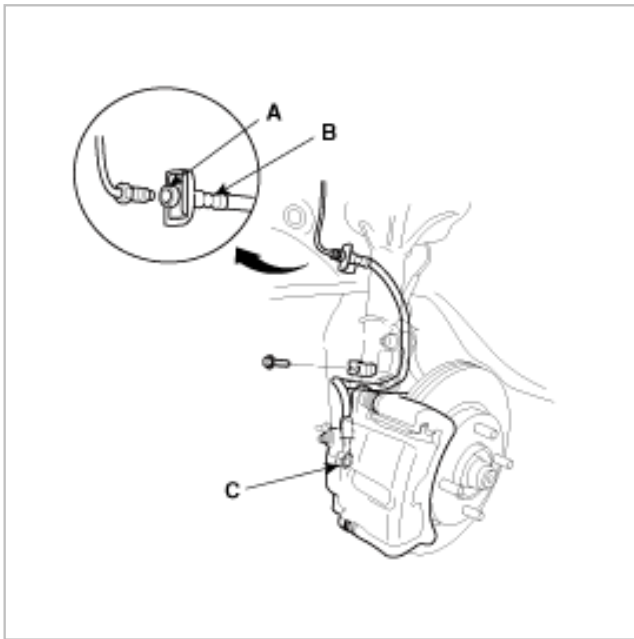

4. Remove the connector bolt (C), and disconnect the brake hose from the caliper.

5. Remove the brake hose from the knuckle.

6. Install the brake hose (A) on the knuckle with 12mm flange bolt (B) first, then connect the brake hose to the caliper with the connector bolt (C) and new sealing washers (D).

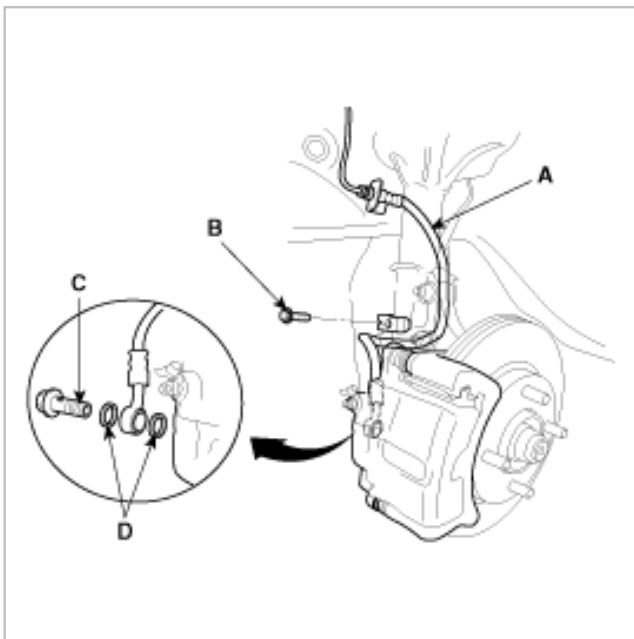

7. Install the brake hose (A) on the upper brake hose bracket (B) with a new brake hose clip (C).

Ebay User ID: reveleus1

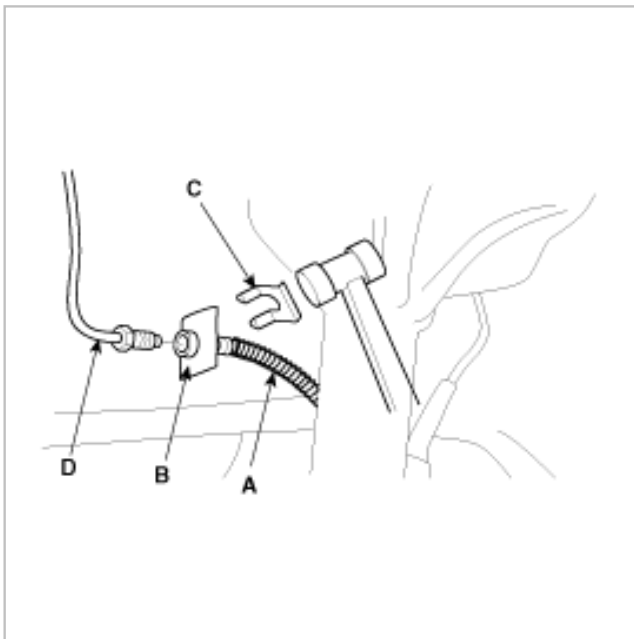

8. Connect the brake line (D) to the brake hose
9. After installing the brake hose, bleed the brake system. (see page BR-12)
10. Perform the following checks.
 - A. Check the brake hose and line joint for leaks, and tighten if necessary.
 - B. Check the brake hoses for interference and twisting.

Inspection

1. Inspect the brake hoses, for damage, deterioration, leaks, interference and twisting.
2. Check the brake lines for damage, rusting, and leakage. Also check for bent brake lines.
3. Check for leaks at hose and line joints or connections, and retighten if necessary.
4. Check the master cylinder for damage and leakage.

NOTE

Replace the brake hose clip whenever the brake hose is serviced.

Replacement

NOTE

- Before reassembling, check that all parts are free of dust and other foreign particles.
- Replace parts with new ones whenever specified to do so.
- Do not spill brake fluid on the vehicle; it may damage the paint; if brake fluid gets on the paint, wash it off immediately with water.

1. Replace the brake hose (A) if the hose is twisted, cracked, or if it leaks.

Ebay User ID: reveleus1

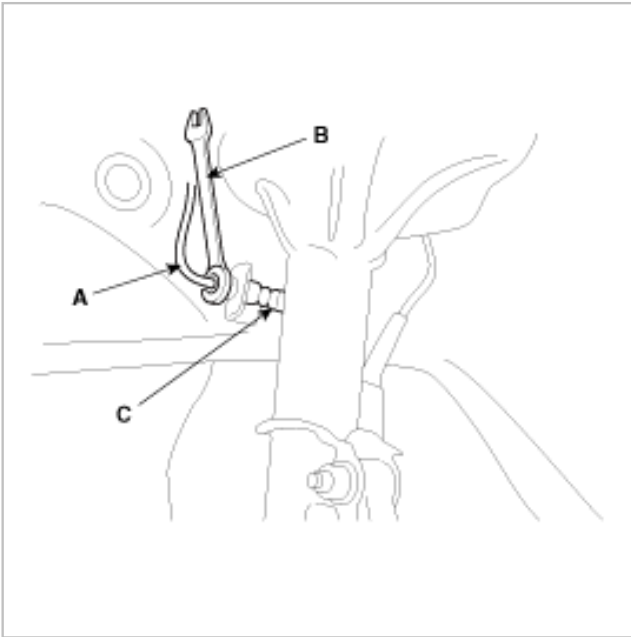

2. Disconnect the brake hose from the brake line (B) using a 10mm flare-nut wrench (C).
3. Remove and discard the brake hose clip (A) from the brake hose (B).

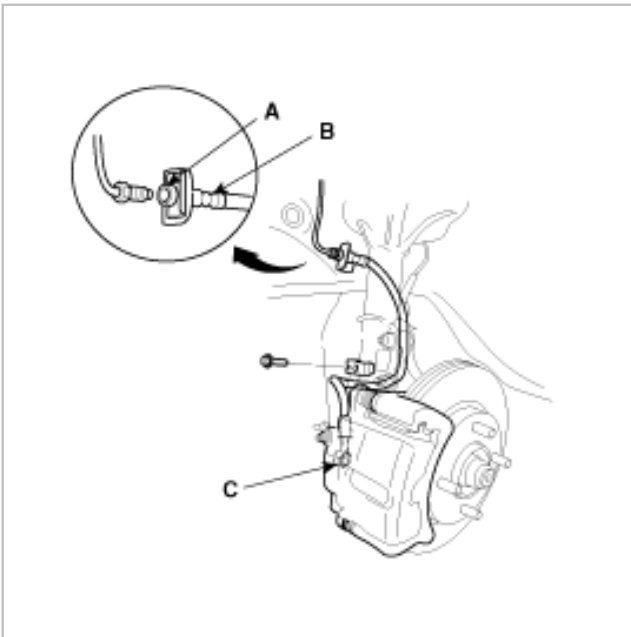

4. Remove the connector bolt (C), and disconnect the brake hose from the caliper.
5. Remove the brake hose from the knuckle.

6. Install the brake hose (A) on the knuckle with 12mm flange bolt (B) first, then connect the brake hose to the caliper with the connector bolt (C) and new sealing washers (D).

Ebay User ID: reveleus1

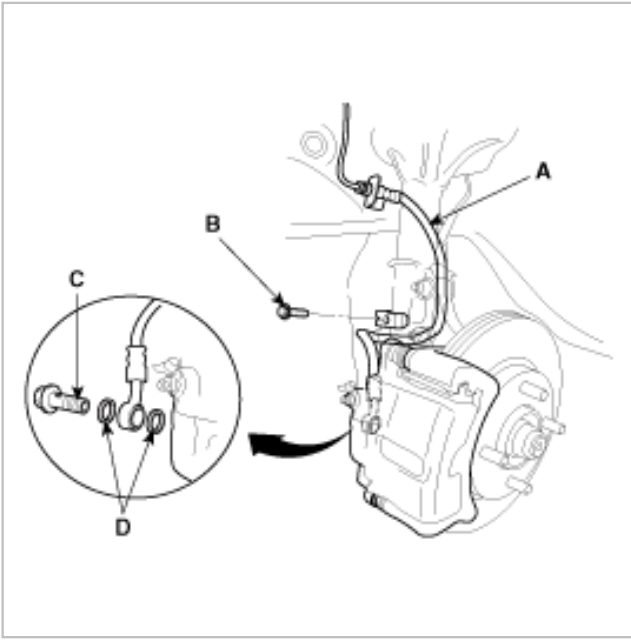

7. Install the brake hose (A) on the upper brake hose bracket (B) with a new brake hose clip (C).

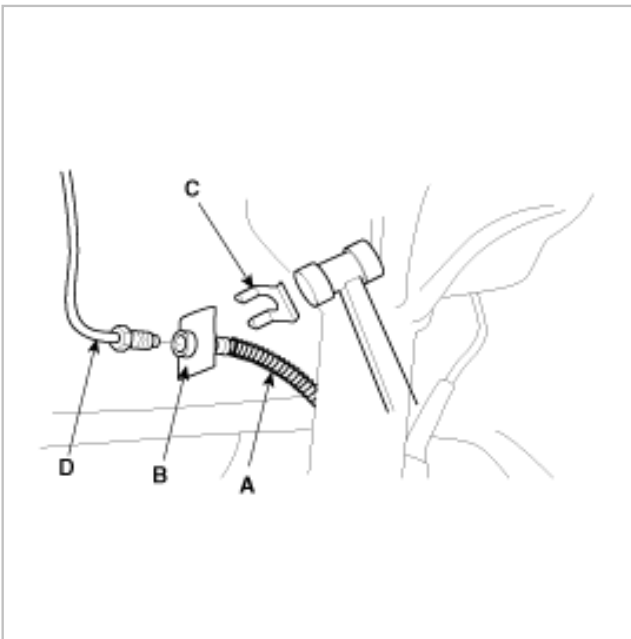

8. Connect the brake line (D) to the brake hose
9. After installing the brake hose, bleed the brake system. (see page BR-12)
10. Perform the following checks.
- A. Check the brake hose and line joint for leaks, and tighten if necessary.
 - B. Check the brake hoses for interference and twisting.

COMPONENTS

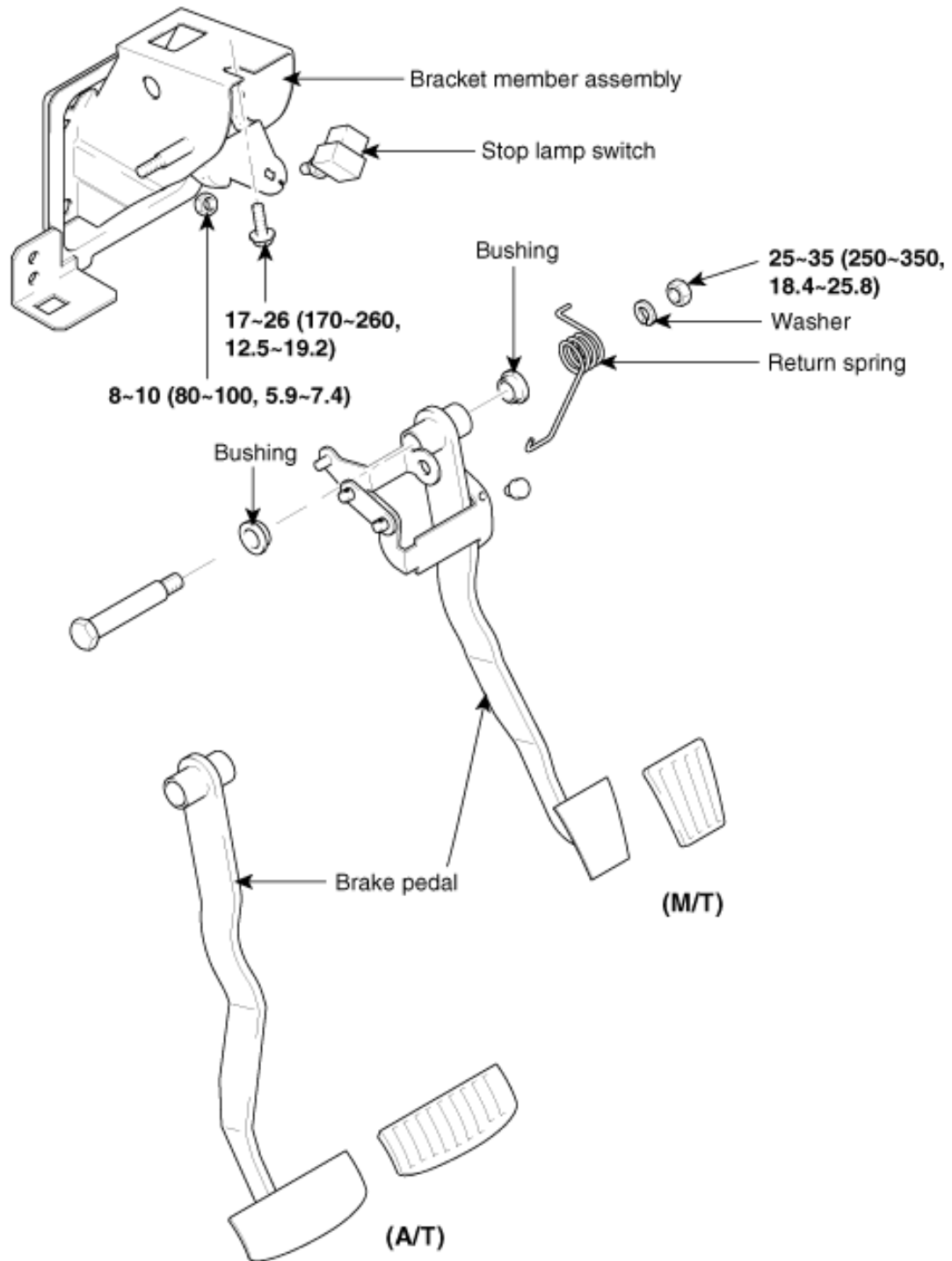

TORQUE: Nm (kgf·cm, lbf·ft)

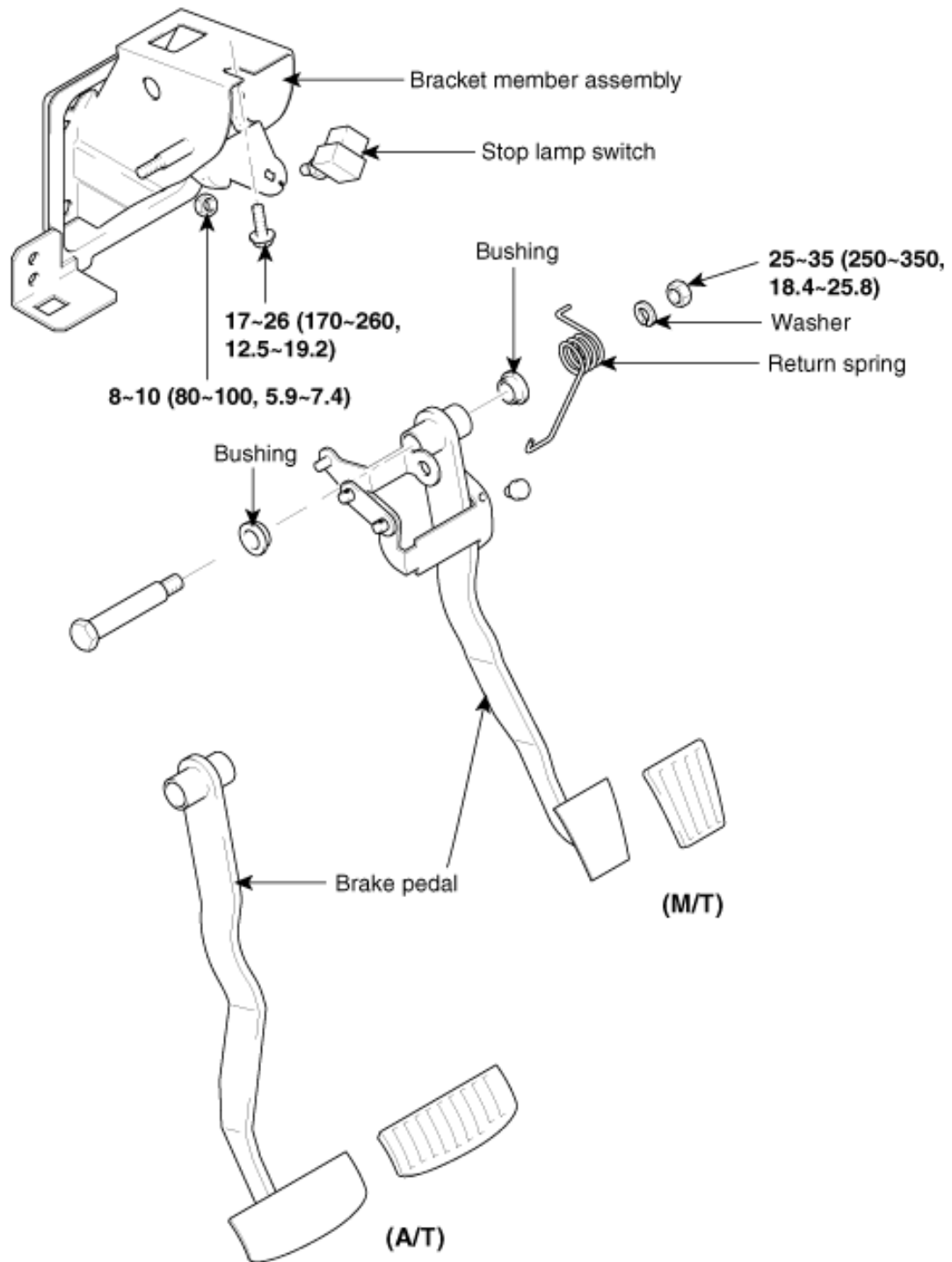

TORQUE: Nm (kgf-cm, lbf-ft)

Component Locating Index

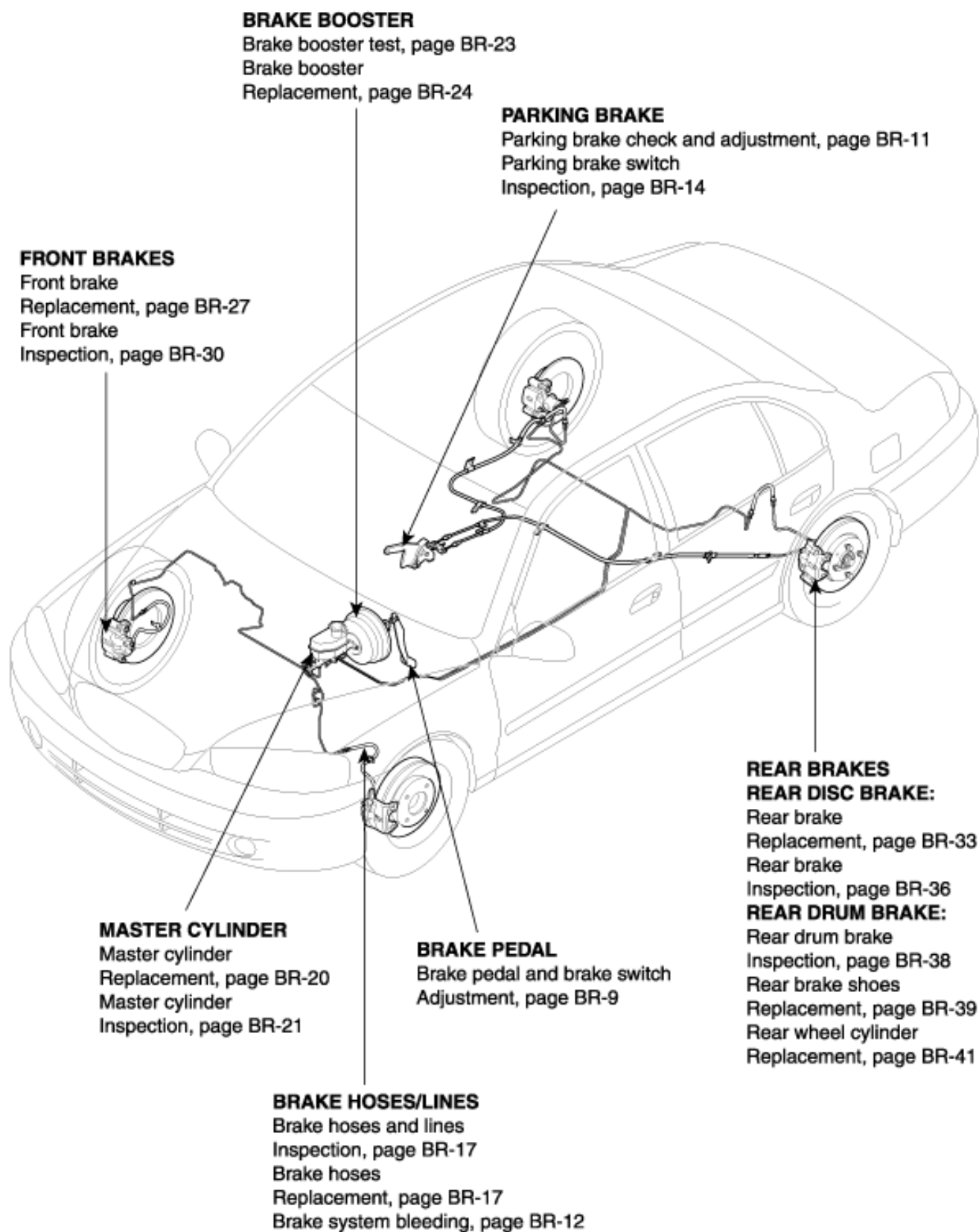

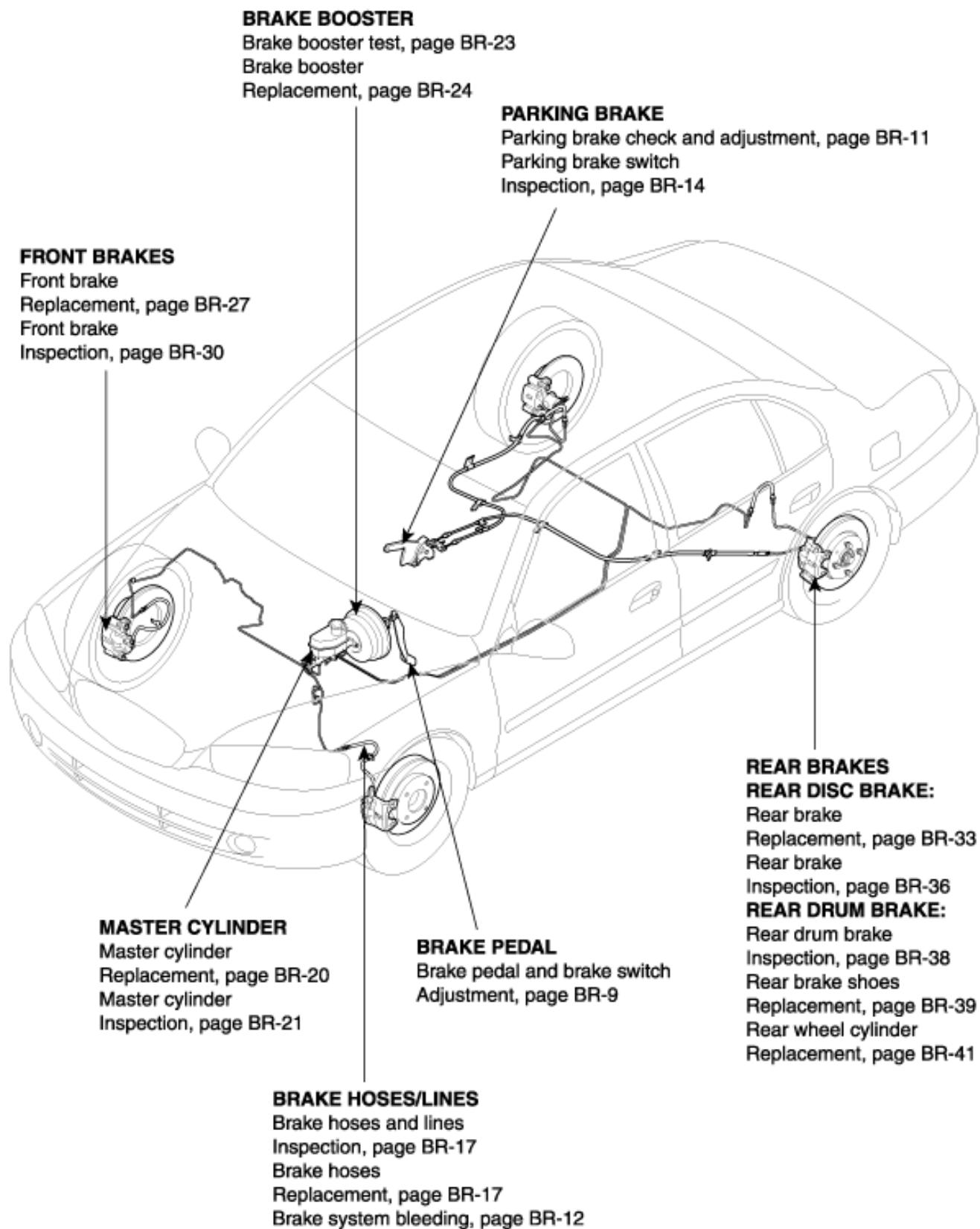

COMPONENTS

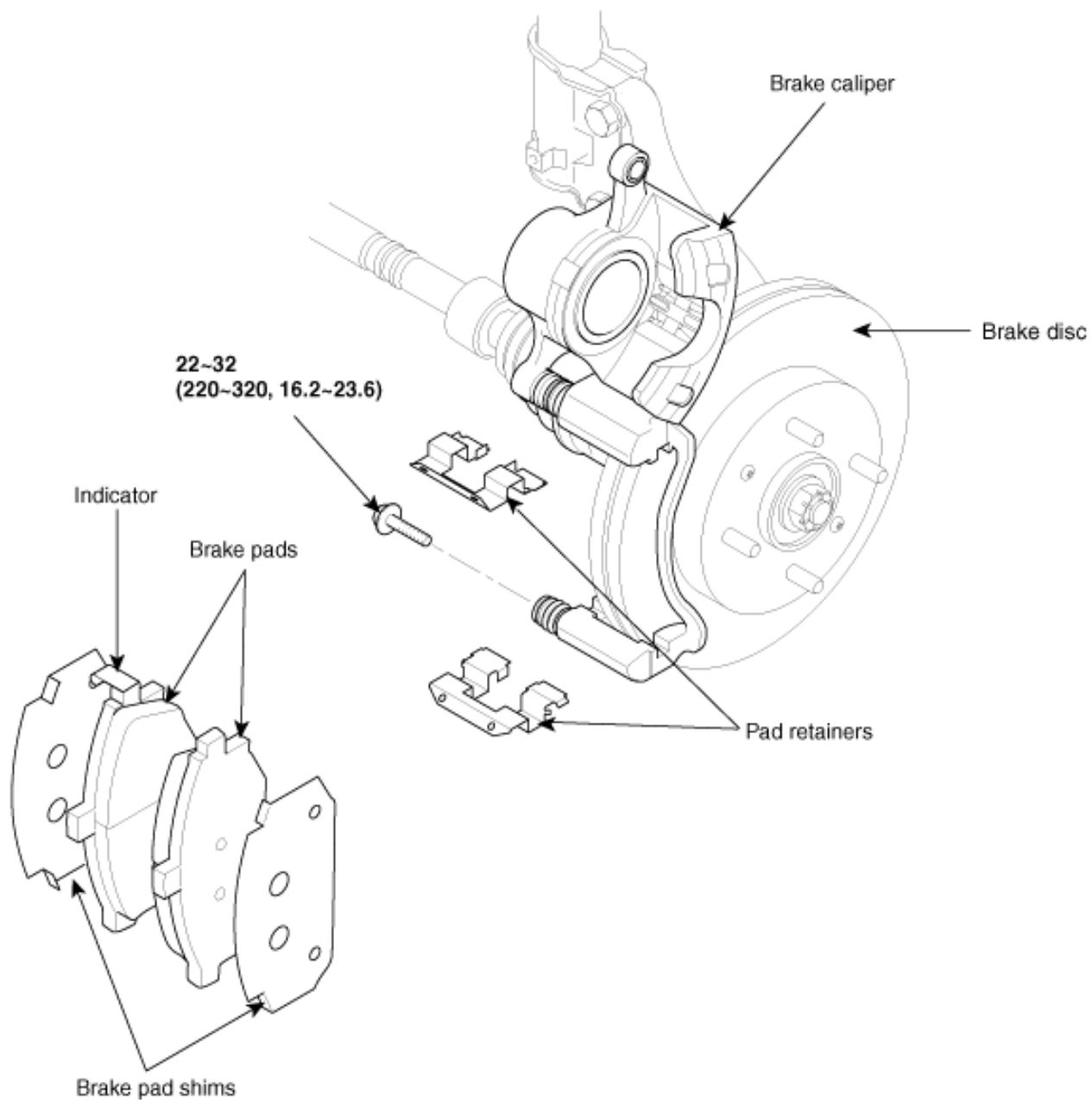

TORQUE: Nm (kgf-cm, lbf-ft)

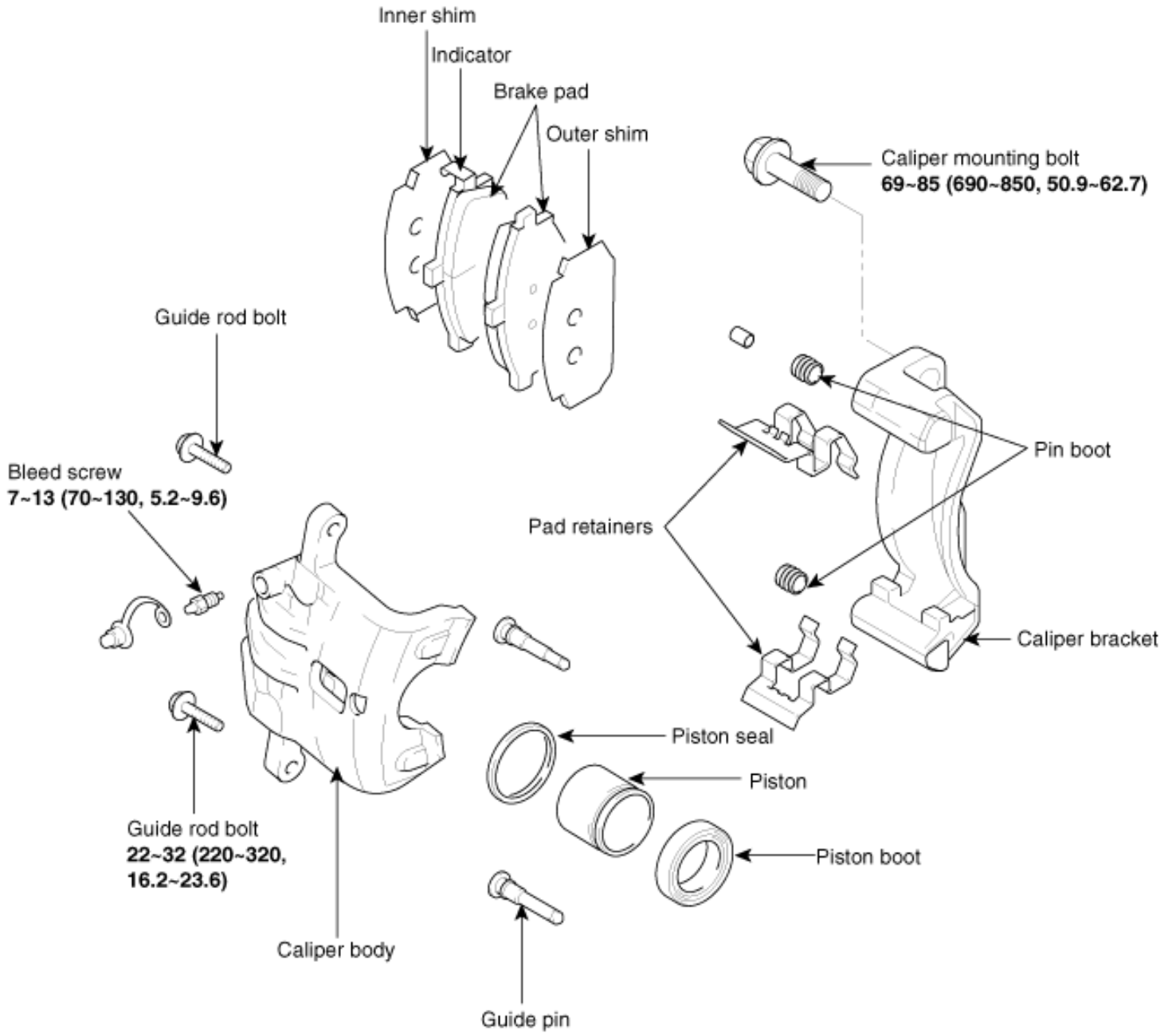

COMPONENTS

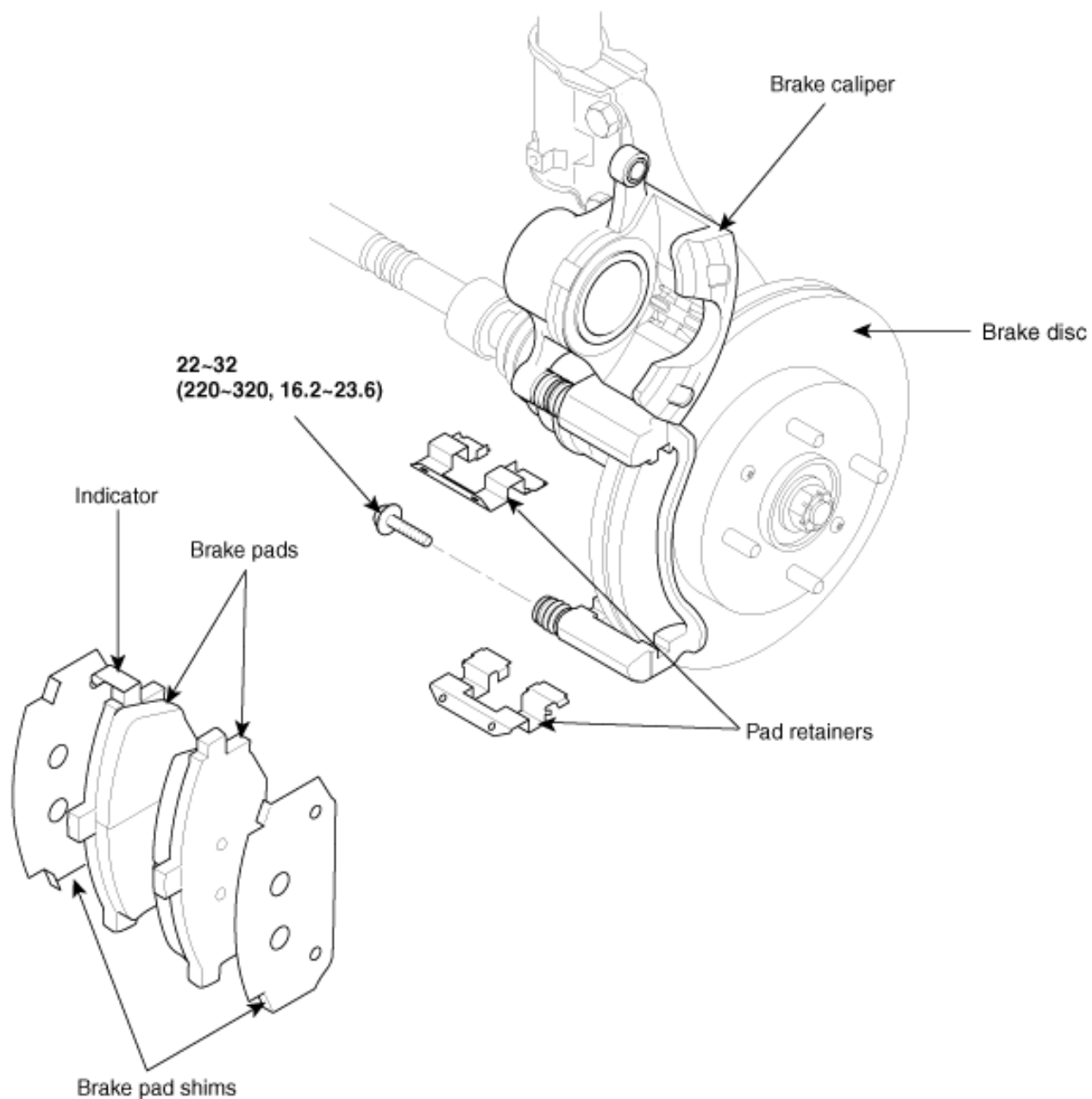

TORQUE: Nm (kgf-cm, lbf-ft)

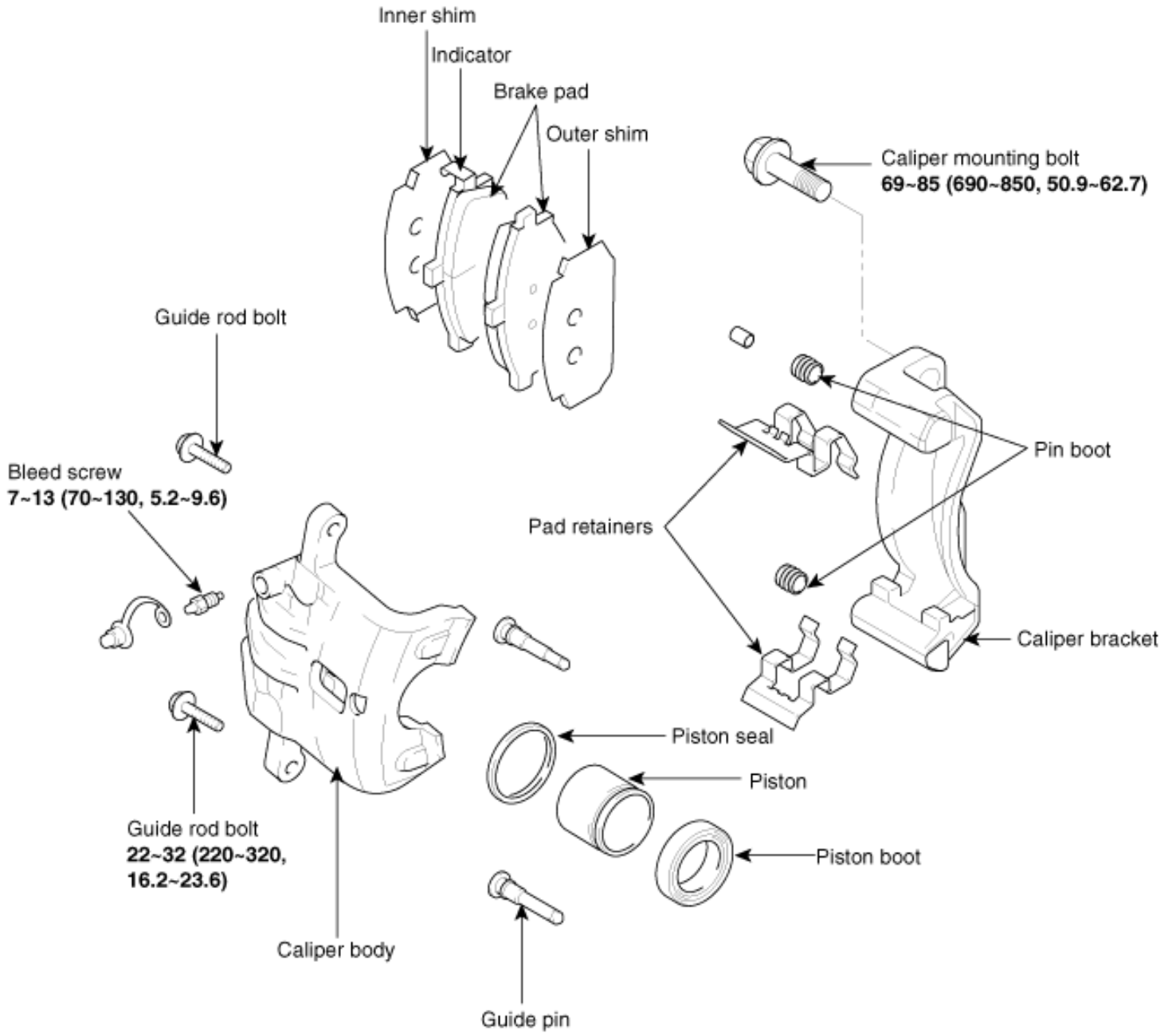



General information

CAUTION

Frequent inhalation of brake pad dust, regardless of material composition, could be hazardous to your health.

- Avoid breathing dust particles.
- Never use an air hose or brush to clean brake assemblies.

Remove, disassemble, inspect, reassemble, and install the caliper and note these items:

- Do not spill brake fluid on the vehicle; it may damage the paint; if brake fluid gets on the paint, wash it off immediately with water.
- To prevent dripping, cover disconnected hose joints with rags or shop towels.
- Clean all parts in brake fluid and air dry; blow out all passages with compressed air.
- Before reassembling, check that all parts are free of dirt and other foreign particles.
- Replace parts with new ones as specified in the illustration.
- Make sure no dirt or other foreign matter gets into the brake fluid.
- Make sure no grease or oil gets on the brake discs or pads.
- When reusing pads, always reinstall them in their original positions to prevent loss of braking efficiency.
- Do not reuse drained brake fluid.
- Always use Genuine DOT 3 or DOT 4 brake fluid. Non Genuine DOT 3 or DOT 4 brake fluid can cause corrosion and shorten the life of the system.
- Coat the piston, piston seal groove, and caliper bore with clean brake fluid.
- Replace all rubber parts with new ones.
- After installing the caliper, check the brake hose and line for leaks, interference, and twisting.

General information

CAUTION

Frequent inhalation of brake pad dust, regardless of material composition, could be hazardous to your health.

- Avoid breathing dust particles.
- Never use an air hose or brush to clean brake assemblies.

Remove, disassemble, inspect, reassemble, and install the caliper and note these items:

- Do not spill brake fluid on the vehicle; it may damage the paint; if brake fluid gets on the paint, wash it off immediately with water.
- To prevent dripping, cover disconnected hose joints with rags or shop towels.
- Clean all parts in brake fluid and air dry; blow out all passages with compressed air.
- Before reassembling, check that all parts are free of dirt and other foreign particles.
- Replace parts with new ones as specified in the illustration.
- Make sure no dirt or other foreign matter gets into the brake fluid.
- Make sure no grease or oil gets on the brake discs or pads.

- Ebay User ID: reveleus1
- When reusing pads, always reinstall them in their original positions to prevent loss of braking efficiency.
 - Do not reuse drained brake fluid.
 - Always use Genuine DOT 3 or DOT 4 brake fluid. Non Genuine DOT 3 or DOT 4 brake fluid can cause corrosion and shorten the life of the system.
 - Coat the piston, piston seal groove, and caliper bore with clean brake fluid.
 - Replace all rubber parts with new ones.
 - After installing the caliper, check the brake hose and line for leaks, interference, and twisting.

REPLACEMENT

CAUTION

Frequent inhalation of brake pad dust, regardless of material composition, could be hazardous to your health.

- Avoid breathing dust particles.
- Never use on air hose or brush to clean brake assemblies.

1. Loosen the front wheel nuts slightly. Raise the front of the vehicle, and make sure it is securely supported. Remove the front wheels.
2. Remove the brake hose mounting bolts (A) from the knuckle.

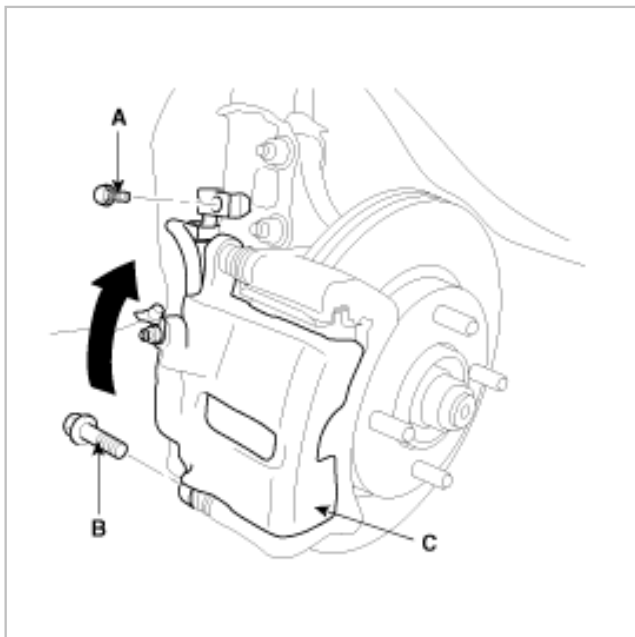

3. Remove guide rod (B) and the caliper (C) up out of the way. Check the hoses and pin boots for damage and deterioration.
4. Remove the pad shims (A), pad retainers (B) and pads (C).

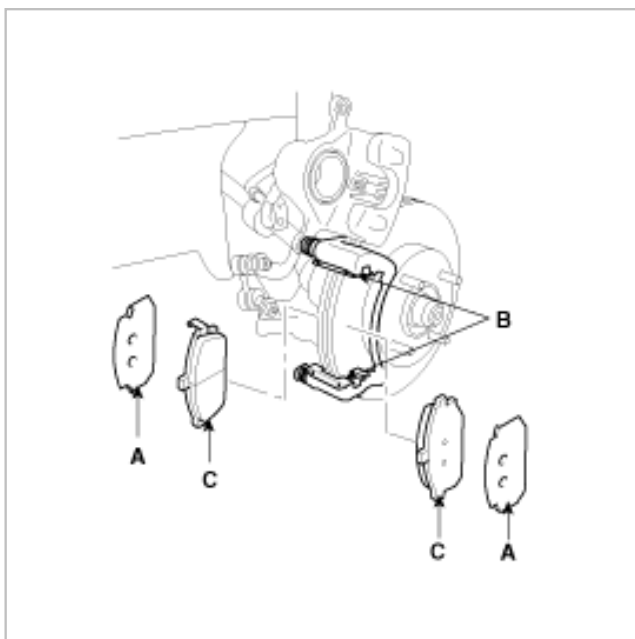

5. Using vernier calipers, measure the thickness of each brake pad lining. The measurement does not include pad backing plate (A) thickness. Ebay User ID: reveleus1

Brake pad thickness:

11mm (0.43 in.)

2mm (0.079 in.)

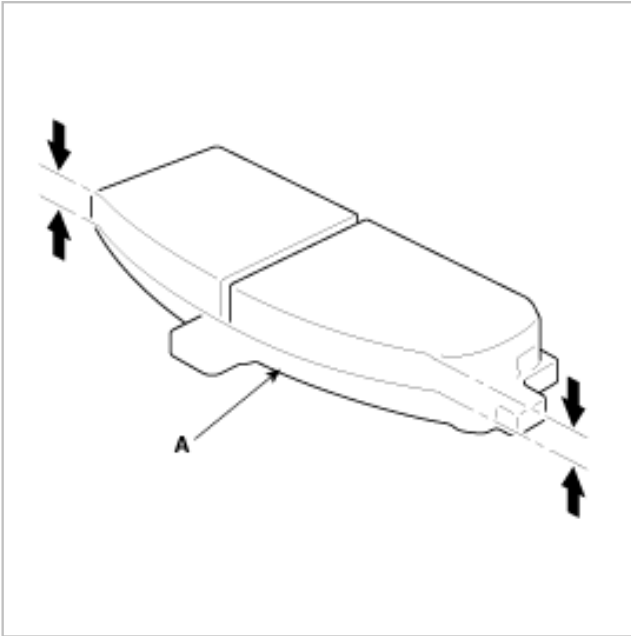

6. If the brake pad thickness is less than service limit, replace the front pads as a set.
7. Clean the caliper thoroughly; remove any rust, and check for grooves and cracks.
8. Check the brake disc for damage and cracks.
9. Install the pad retainers (A).

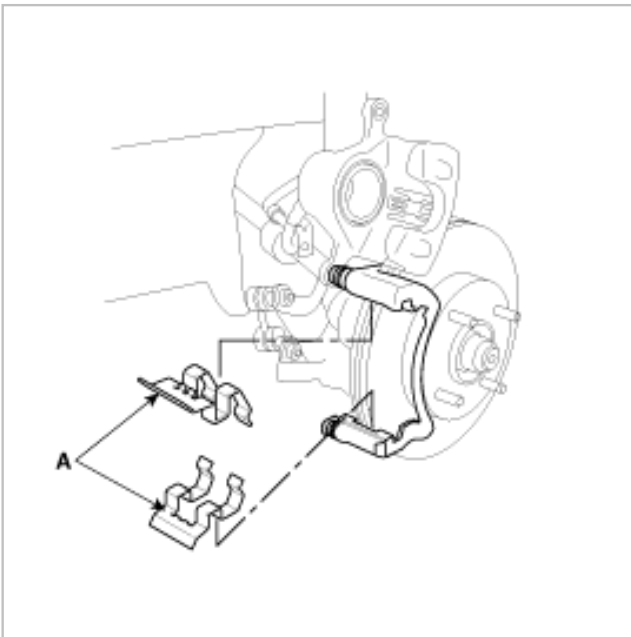

10. Check the foreign material at the pad shims (A) and the back of the pads (B).

Ebay User ID: reveleus1

Contaminated brake discs or pads reduce stopping ability. Keep grease off the discs and pads.

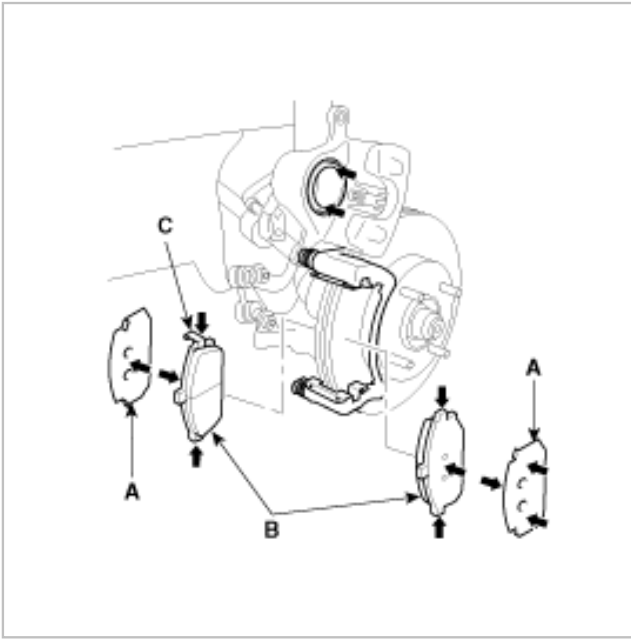

11. Install the brake pads (B) and pad shims (A) correctly. Install the pad with the wear indicator (C) on the inside. If you are reusing the pads, always reinstall the brake pads in their original positions to prevent a momentary loss of braking efficiency.

12. Push in the piston (A) so that the caliper will fit over the pads. Make sure that the piston boot is in position to prevent damaging it when pivoting the caliper down.

13. Pivot the caliper down into position. Being careful not to damage the pin boot, install the guide rod bolt (B) and torque it to proper specification.

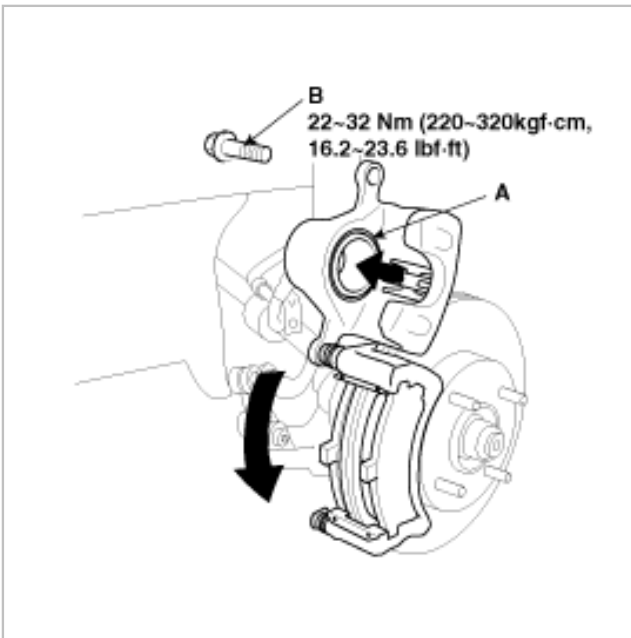

NOTE

Ebay User ID: reveleus1

Insert the piston in the cylinder using the special tool (09581-11000).

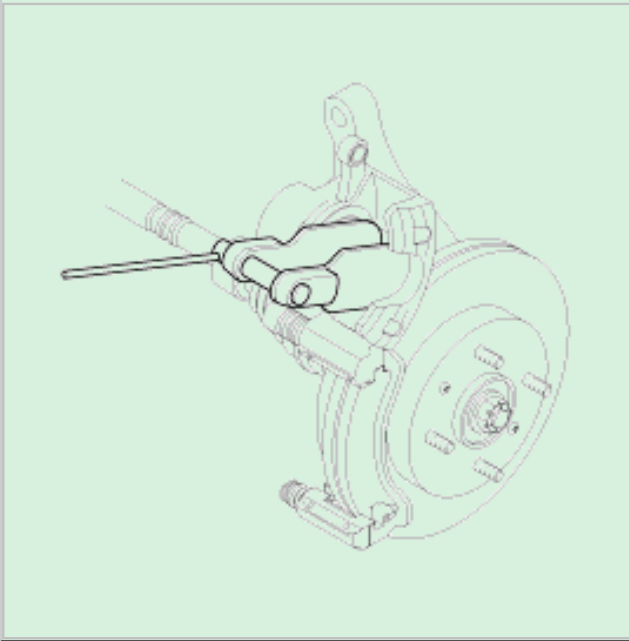

14. Install the brake hose on to the knuckle.
15. Depress the brake pedal several times to make sure the brakes work, then test-drive.

NOTE

Engagement of the brake may require a greater pedal stroke immediately after the brake pads have been replaced as a set. Several applications of the brake will restore the normal pedal stroke.

16. After installation, check for leaks at hose and line joints or connections, and retighten if necessary.

INSPECTION

Runout

1. Loosen the front wheel nuts slightly, then raise the vehicle and make sure it is securely supported.
Remove the front wheels.
2. Remove the brake pads (see page BR-27).
3. Inspect the disc surface for damage and cracks.
Clean the disc thoroughly and remove all rust.
4. Use wheel nuts and suitable flat washers (A) to hold the disc securely against the hub, then mount a dial indicator as shown, and measure the runout at 10 mm (0.4 in.) from the outer edge of the disc.

Brake disc runout:

0.10 mm (0.004 in.)

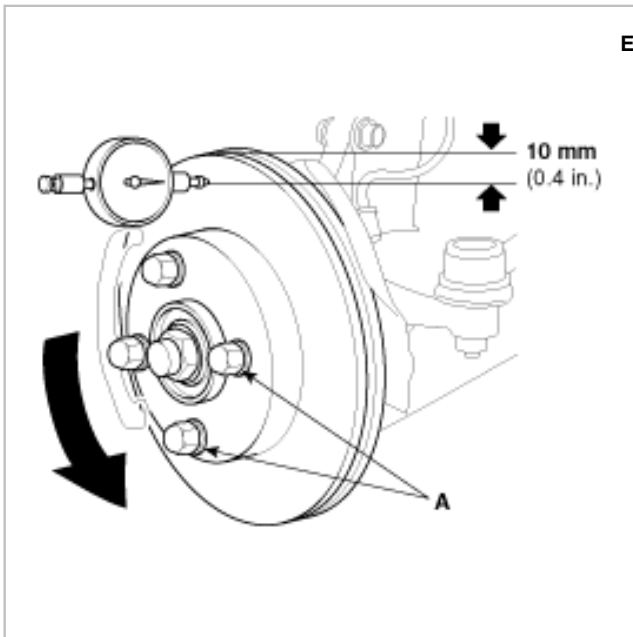

5. If the disc is beyond the service limit, refinish the brake disc with an on-car brake lathe.

22.4 mm (0.882 in.)

NOTE

- If the brake disc is beyond the service limit for refinishing, replace it (see page BR-27).
- A new disc should be refinished if its runout is greater than 0.10 mm (0.004 in.).

Thickness and parallelism

1. Loosen the front wheel nuts slightly, then raise the vehicle and make sure it is securely supported.
Remove the front wheels.
2. Remove the brake pads (see page BR-27)
3. Using measure disc thickness at eight points, approximately 45° apart and 10 mm (0.4 in.) in from the outer edge of the disc. Replace the brake disc of the smallest measurement is less than the max. refinishing limit.

Brake disc thickness:

- 24 mm (0.945 in.)
- 22.4 mm (0.882 in.)
- Max. 0.015 mm (0.0006 in.)

NOTE

Ebay User ID: reveleus1

This is the maximum allowable difference between the thickness measurements.

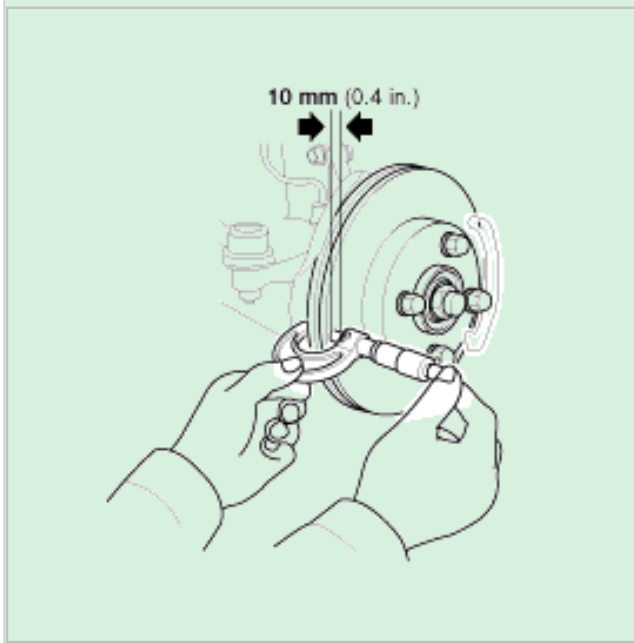

4. If the disc is beyond the service limit for parallelism, refinish the brake disc with an on-car brake lathe.

NOTE

If the brake disc is beyond the service limit for refinishing, replace it (see DS group-front axle).

REPLACEMENT

CAUTION

Frequent inhalation of brake pad dust, regardless of material composition, could be hazardous to your health.

- Avoid breathing dust particles.
- Never use on air hose or brush to clean brake assemblies.

1. Loosen the front wheel nuts slightly. Raise the front of the vehicle, and make sure it is securely supported. Remove the front wheels.
2. Remove the brake hose mounting bolts (A) from the knuckle.

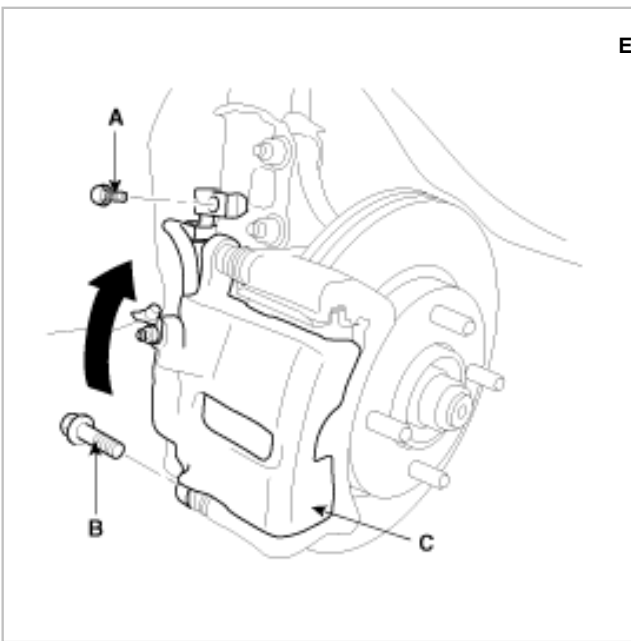

3. Remove guide rod (B) and the caliper (C) up out of the way. Check the hoses and pin boots for damage and deterioration.
4. Remove the pad shims (A), pad retainers (B) and pads (C).

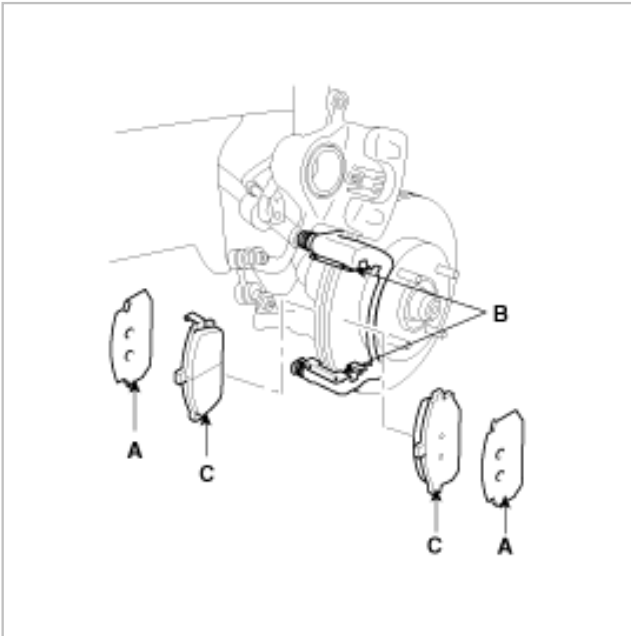

5. Using vernier calipers, measure the thickness of each brake pad lining. The measurement does not include pad backing plate (A) thickness.

Brake pad thickness:

11mm (0.43 in.)
2mm (0.079 in.)

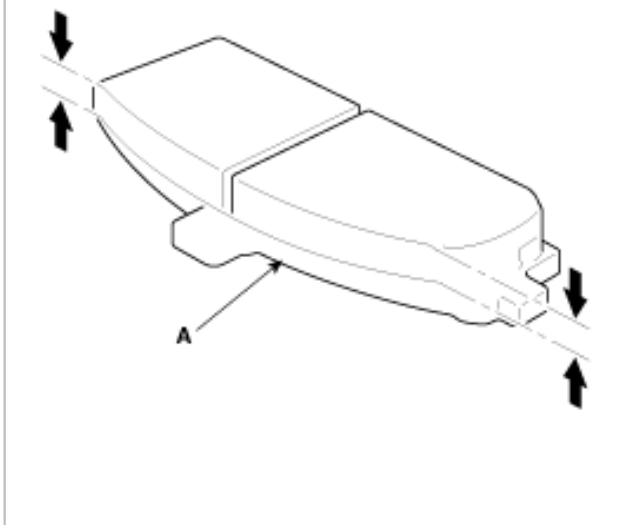

6. If the brake pad thickness is less than service limit, replace the front pads as a set.
7. Clean the caliper thoroughly; remove any rust, and check for grooves and cracks.
8. Check the brake disc for damage and cracks.
9. Install the pad retainers (A).

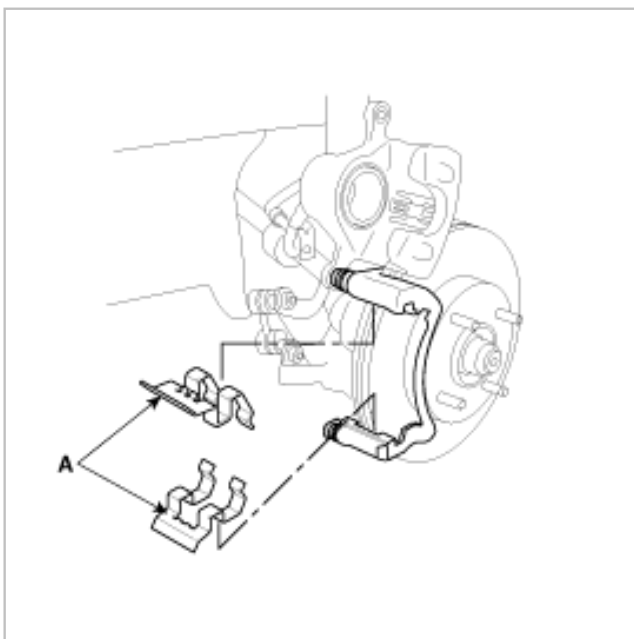

10. Check the foreign material at the pad shims (A) and the back of the pads (B).
Contaminated brake discs or pads reduce stopping ability. Keep grease off the discs and pads.

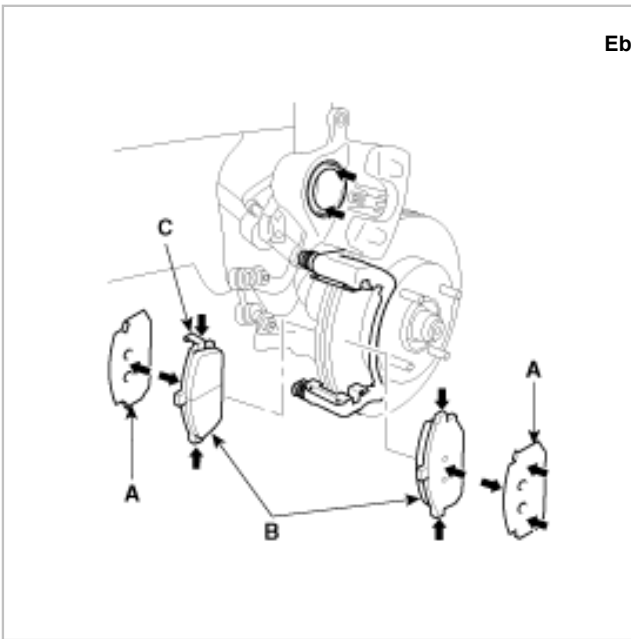

11. Install the brake pads (B) and pad shims (A) correctly. Install the pad with the wear indicator (C) on the inside. If you are reusing the pads, always reinstall the brake pads in their original positions to prevent a momentary loss of braking efficiency.
12. Push in the piston (A) so that the caliper will fit over the pads. Make sure that the piston boot is in position to prevent damaging it when pivoting the caliper down.
13. Pivot the caliper down into position. Being careful not to damage the pin boot, install the guide rod bolt (B) and torque it to proper specification.

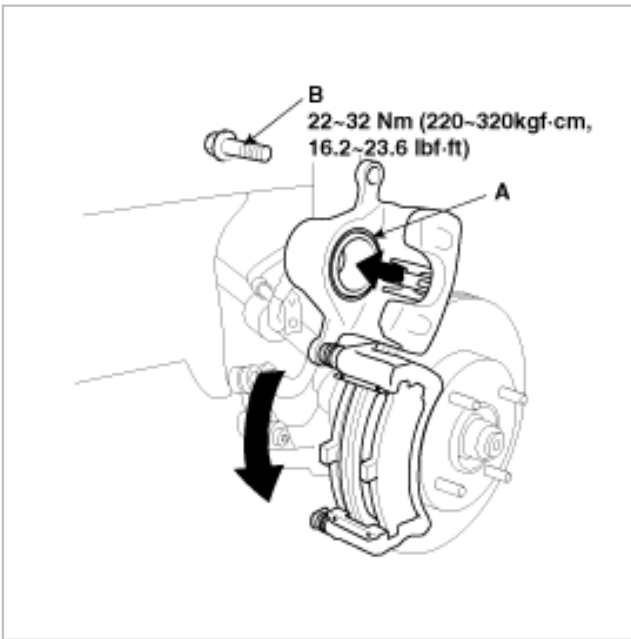

NOTE

Ebay User ID: reveleus1

Insert the piston in the cylinder using the special tool (09581-11000).

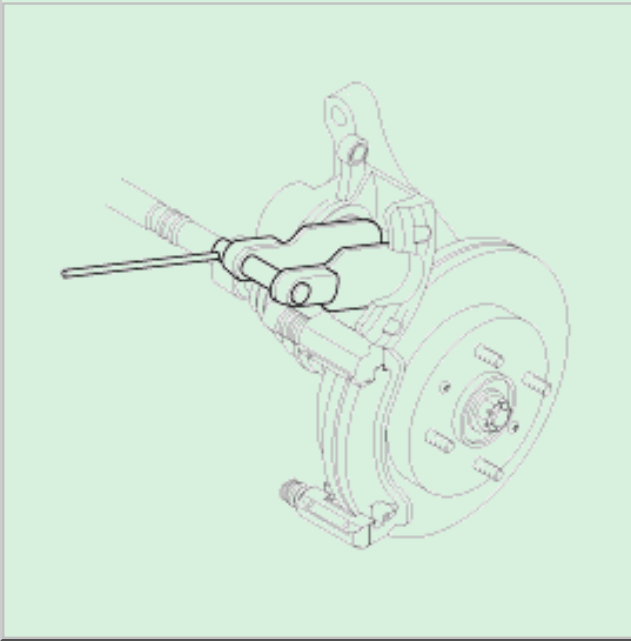

14. Install the brake hose on to the knuckle.
15. Depress the brake pedal several times to make sure the brakes work, then test-drive.

NOTE

Engagement of the brake may require a greater pedal stroke immediately after the brake pads have been replaced as a set. Several applications of the brake will restore the normal pedal stroke.

16. After installation, check for leaks at hose and line joints or connections, and retighten if necessary.

INSPECTION

Runout

1. Loosen the front wheel nuts slightly, then raise the vehicle and make sure it is securely supported.
Remove the front wheels.
2. Remove the brake pads (see page BR-27).
3. Inspect the disc surface for damage and cracks.
Clean the disc thoroughly and remove all rust.
4. Use wheel nuts and suitable flat washers (A) to hold the disc securely against the hub, then mount a dial indicator as shown, and measure the runout at 10 mm (0.4 in.) from the outer edge of the disc.

Brake disc runout:

0.10 mm (0.004 in.)

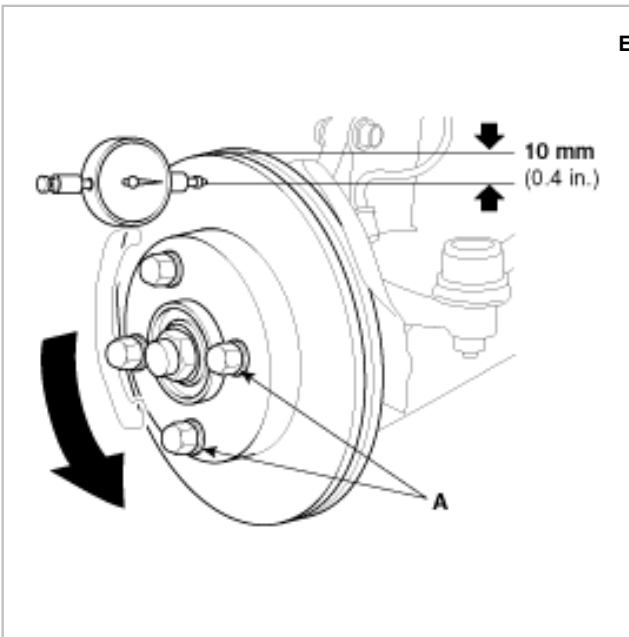

5. If the disc is beyond the service limit, refinish the brake disc with an on-car brake lathe.

22.4 mm (0.882 in.)

NOTE

- If the brake disc is beyond the service limit for refinishing, replace it (see page BR-27).
- A new disc should be refinished if its runout is greater than 0.10 mm (0.004 in.).

Thickness and parallelism

1. Loosen the front wheel nuts slightly, then raise the vehicle and make sure it is securely supported.
Remove the front wheels.
2. Remove the brake pads (see page BR-27)
3. Using measure disc thickness at eight points, approximately 45° apart and 10 mm (0.4 in.) in from the outer edge of the disc. Replace the brake disc of the smallest measurement is less than the max. refinishing limit.

Brake disc thickness:

24 mm (0.945 in.)

22.4 mm (0.882 in.)

Max. 0.015 mm (0.0006 in.)

NOTE

Ebay User ID: reveleus1

This is the maximum allowable difference between the thickness measurements.

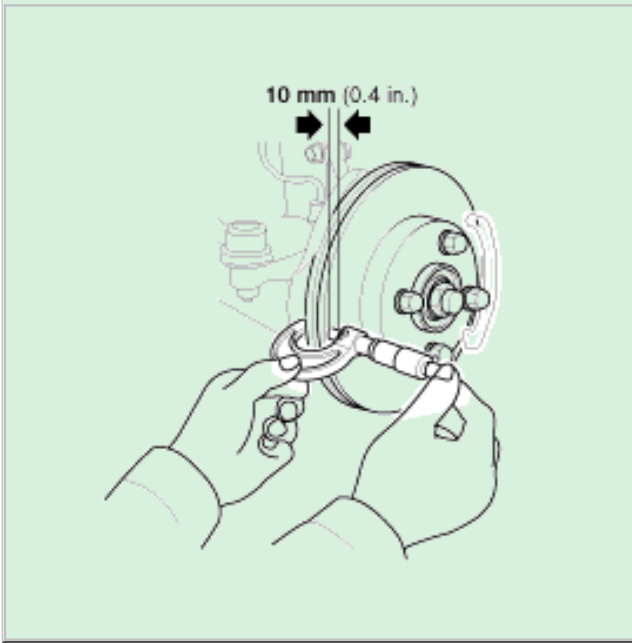

4. If the disc is beyond the service limit for parallelism, refinish the brake disc with an on-car brake lathe.

NOTE

If the brake disc is beyond the service limit for refinishing, replace it (see DS group-front axle).

COMPONENTS

[FRONT]

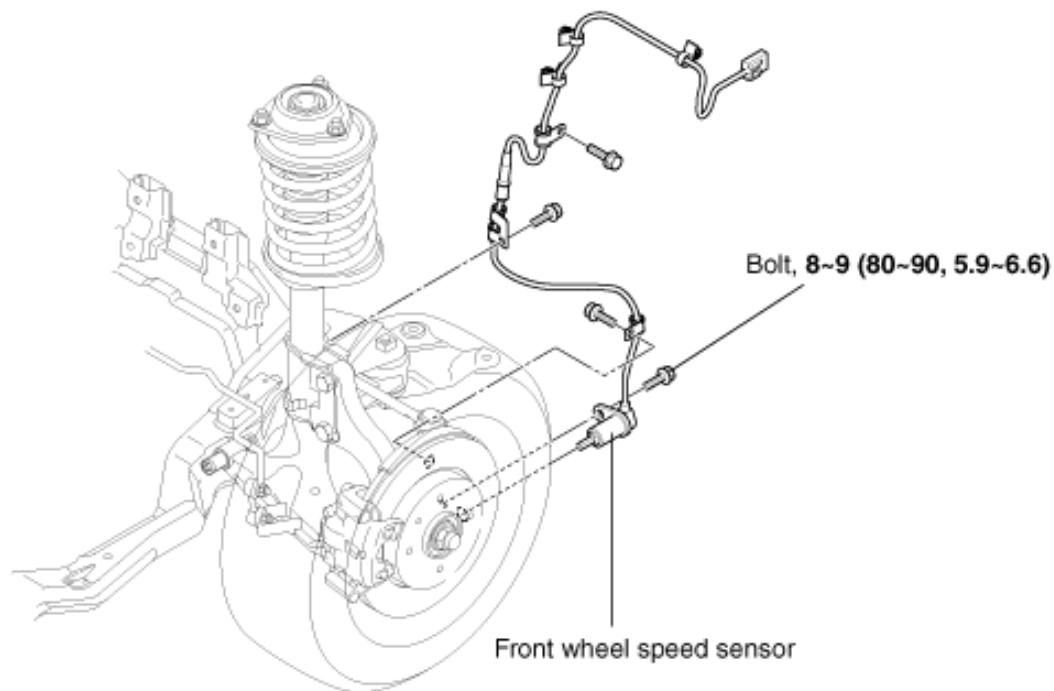

[REAR]

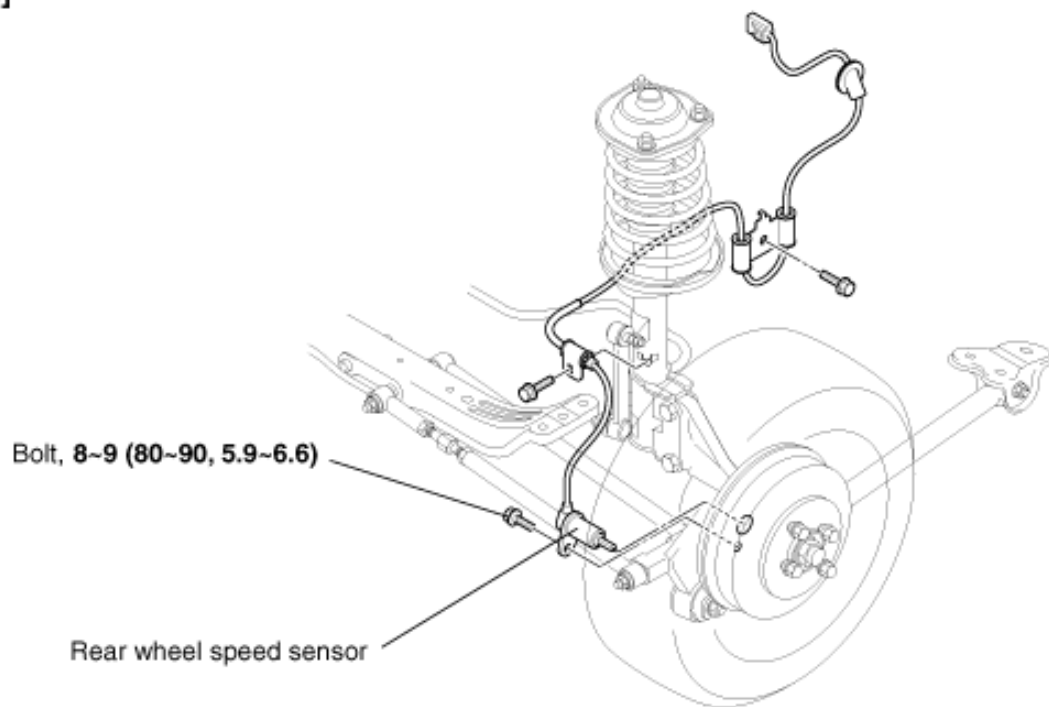

TORQUE: Nm (kg-cm, lb-ft)

Purchased
from Ebay seller
Reveleus1

Thank-you for purchasing from me, it
is much appreciated.

To contact me please email
suzlever@gmail.com

REMOVAL

FRONT WHEEL SPEED SENSOR

1. Remove the front wheel speed sensor mounting bolt (A).

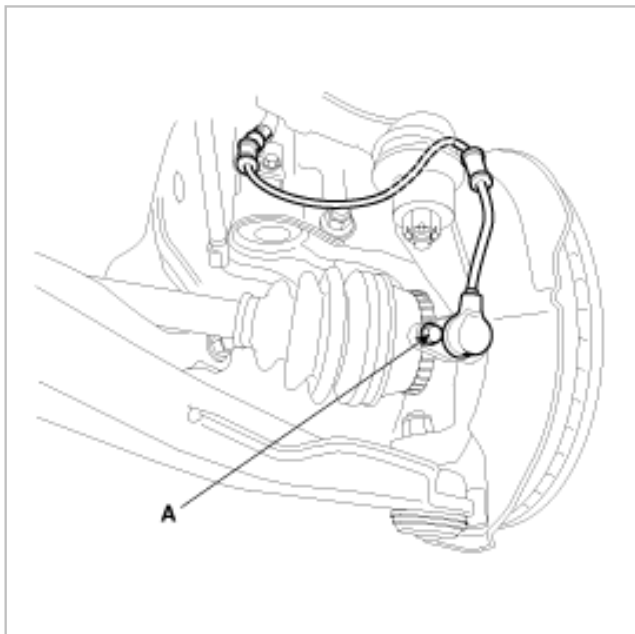

2. Remove the front wheel guard (A).

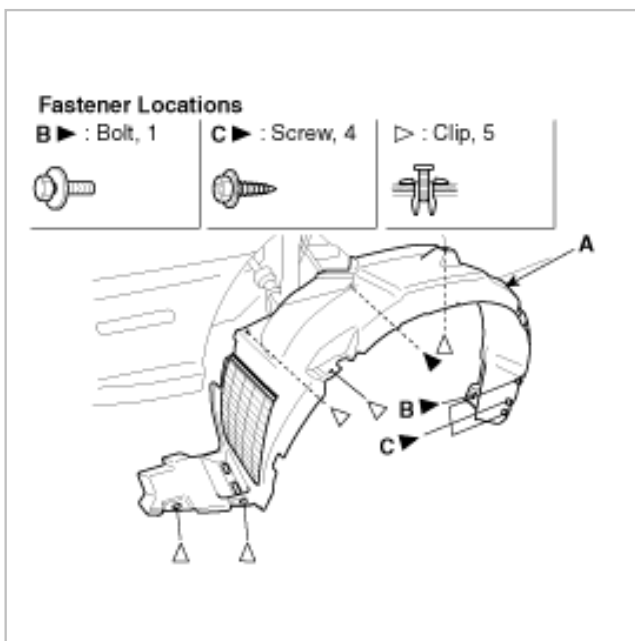

3. Remove the front wheel speed sensor after disconnecting the wheel speed sensor connector (A).

Ebay User ID: reveleus1

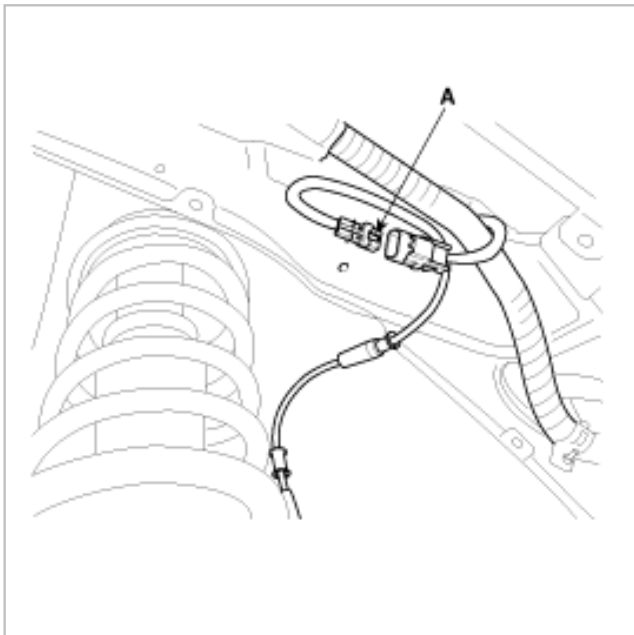

REAR WHEEL SPEED SENSOR

1. Remove the rear wheel speed sensor mounting bolt (A).

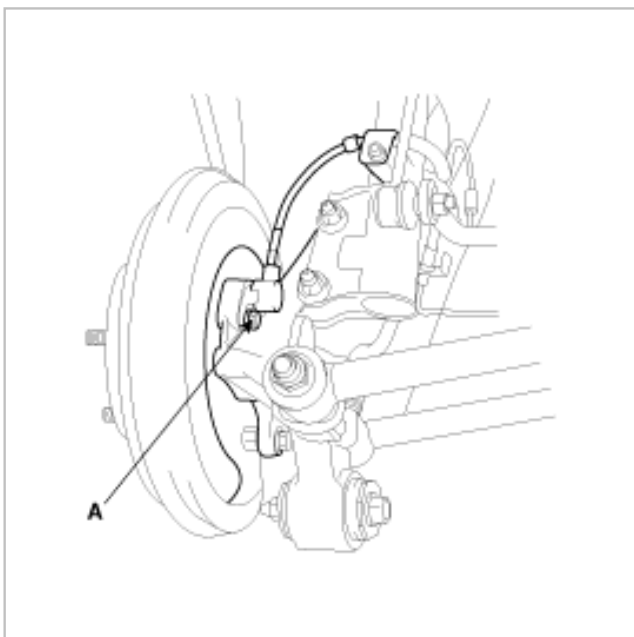

2. Remove the rear seat side pad then disconnect the rear wheel speed sensor connector (A).

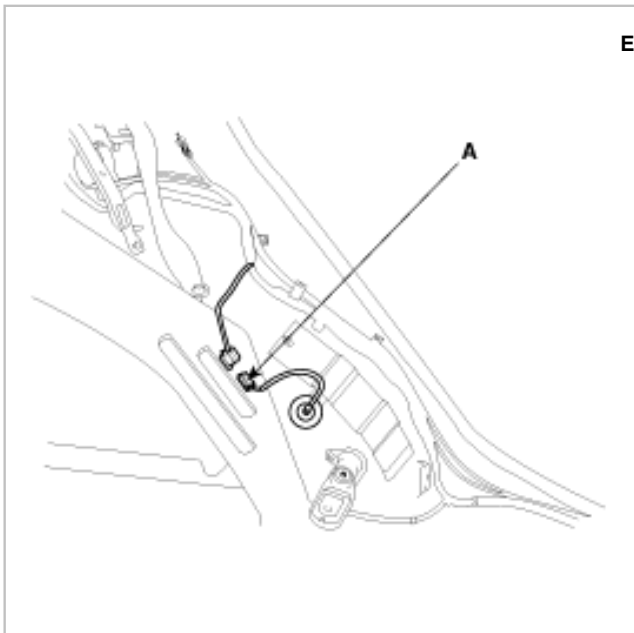

INSPECTION

1. Connect an ohmmeter between the wheel speed sensor terminals and measure the resistance.

Service standard

Front : 1275 ~ 1495

Rear : 1275 ~ 1495

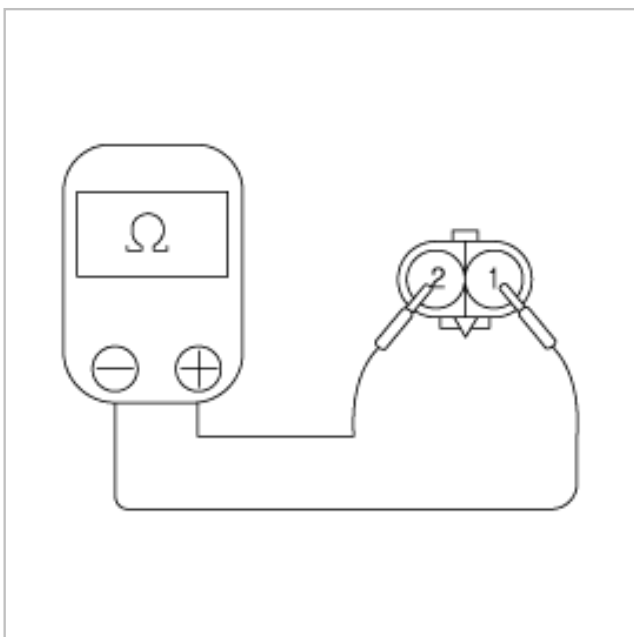

2. Connect a voltmeter between the wheel speed sensor terminals and measure the voltage by turning the wheel.
Ebay User ID: reveleus1

NOTE

Set the voltmeter to measure AC voltage.

Service standard: AC voltage detected.

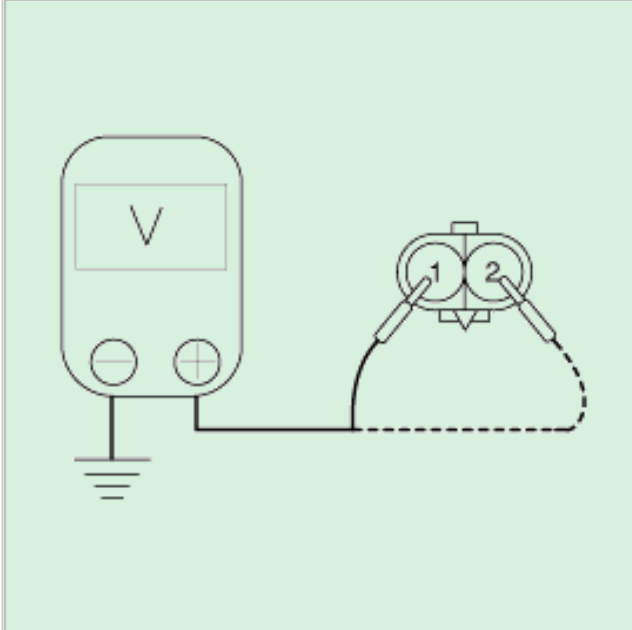



PRECAUTION

- Care must be taken to replace each part properly as it could affect the performance of the brake system and result in a driving hazard. Replace the parts with parts of the same part number or equivalent.
- It is very important to keep parts and the area clean when repairing the brake system.

PRECAUTION

- Care must be taken to replace each part properly as it could affect the performance of the brake system and result in a driving hazard. Replace the parts with parts of the same part number or equivalent.
- It is very important to keep parts and the area clean when repairing the brake system.

COMPONENTS

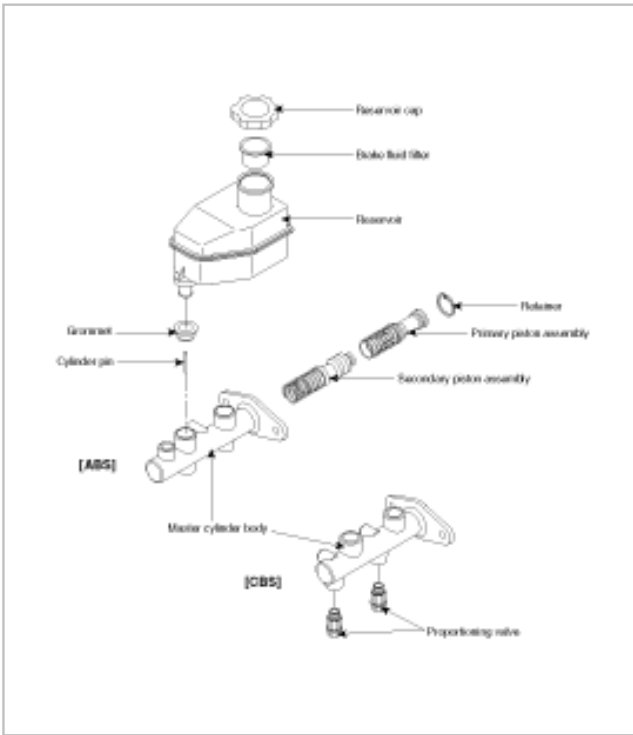

COMPONENTS

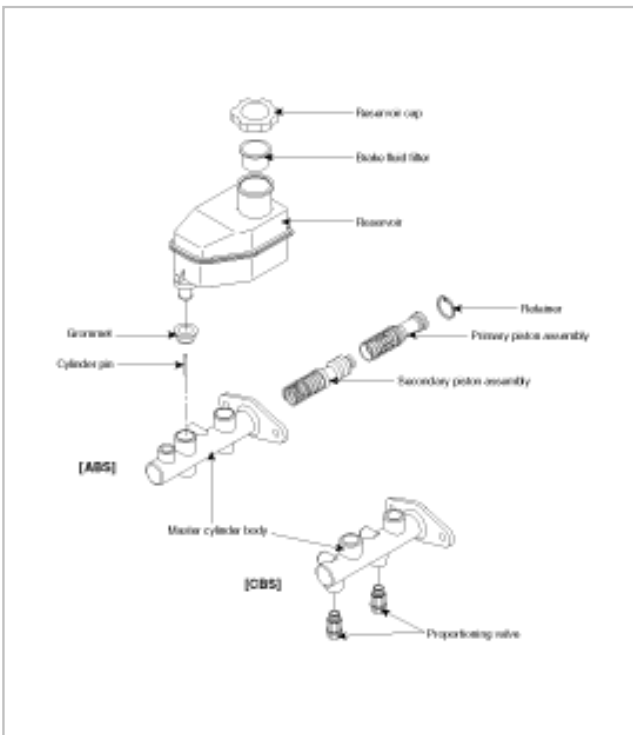

Replacement

NOTE

Do not spill brake fluid on the vehicle; it may damage the paint; if brake fluid does contact the paint, wash it off immediately with water.

1. Remove the air cleaner cover (A), air filter (B), air cleaner mounting bolts (C) and air cleaner body (D) from the air cleaner mounting bracket (E).

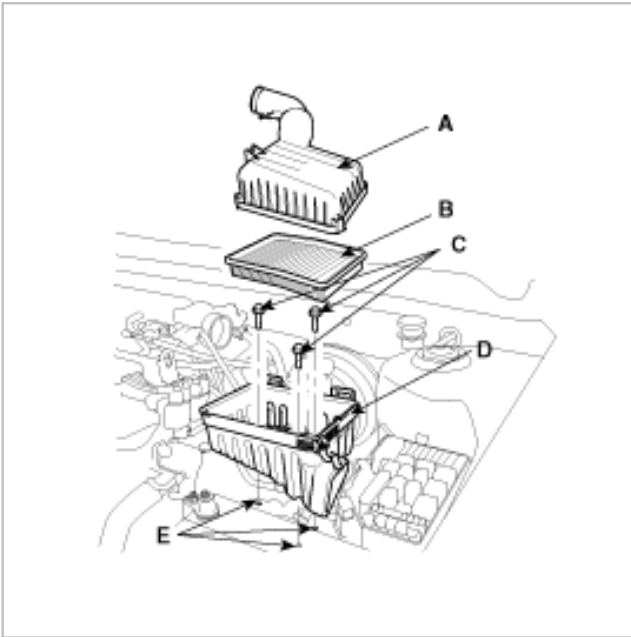

2. Disconnect the brake fluid level switch connectors(A), and remove the reservoir cap(B).

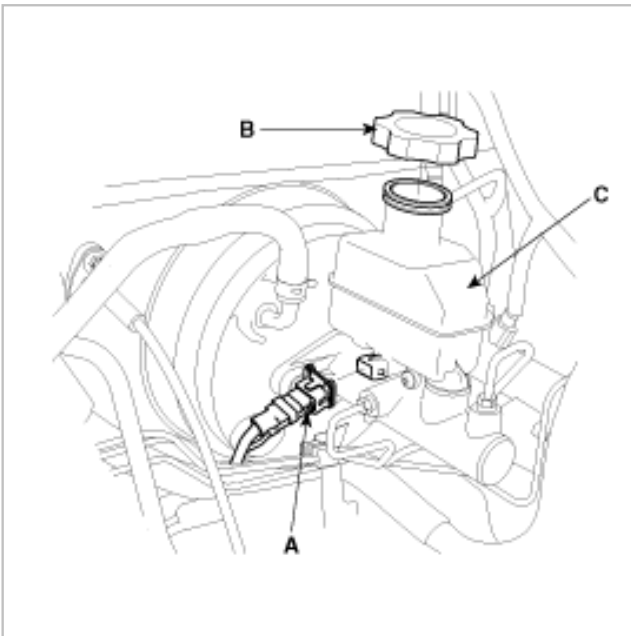

3. Remove the brake fluid from the master cylinder reservoir(C) with a syringe.

4. Disconnect the brake lines(A) from the master cylinder. To prevent spills, cover the hose joints with rags or shop towels.
Ebay User ID: reveleus1

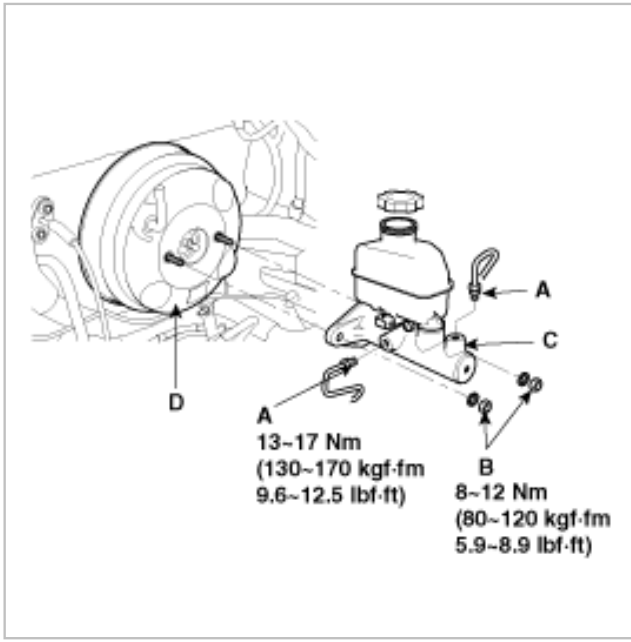

5. Remove the master cylinder mounting nuts(B) and washers.
6. Remove the master cylinder(C) from the brake booster(D). Be careful not to bend or damage the brake lines when removing the master cylinder.
7. Install the master cylinder in the reverse order of removal, and note these items:
- A. Replace all rubber parts with new ones whenever, removed.

INSPECTION

NOTE

- Before reassembling, check that all parts are free of dust and other foreign particles.
- Do not try to disassemble the master cylinder assembly. Replace the master cylinder assembly with a new part if necessary.
- Do not allow dirt or foreign matter to contaminate the brake fluid.

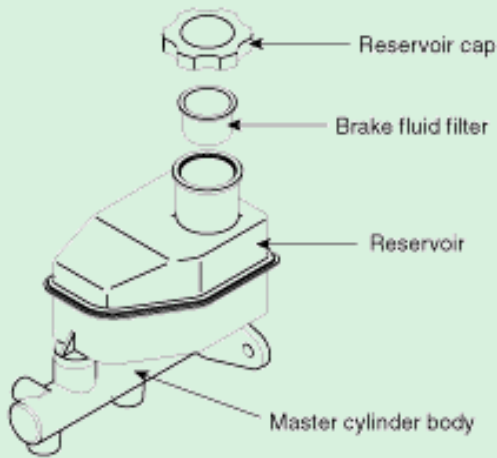

Replacement

NOTE

Do not spill brake fluid on the vehicle; it may damage the paint; if brake fluid does contact the paint, wash it off immediately with water.

1. Remove the air cleaner cover (A), air filter (B), air cleaner mounting bolts (C) and air cleaner body (D) from the air cleaner mounting bracket (E).

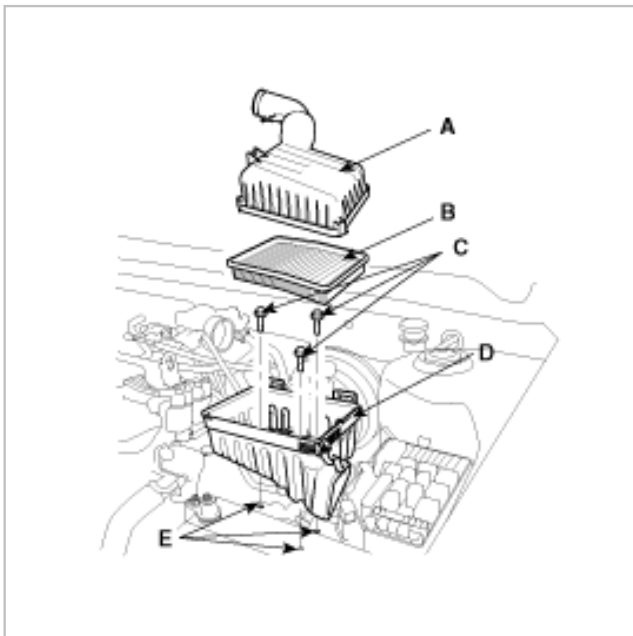

2. Disconnect the brake fluid level switch connectors(A), and remove the reservoir cap(B).

Ebay User ID: reveleus1

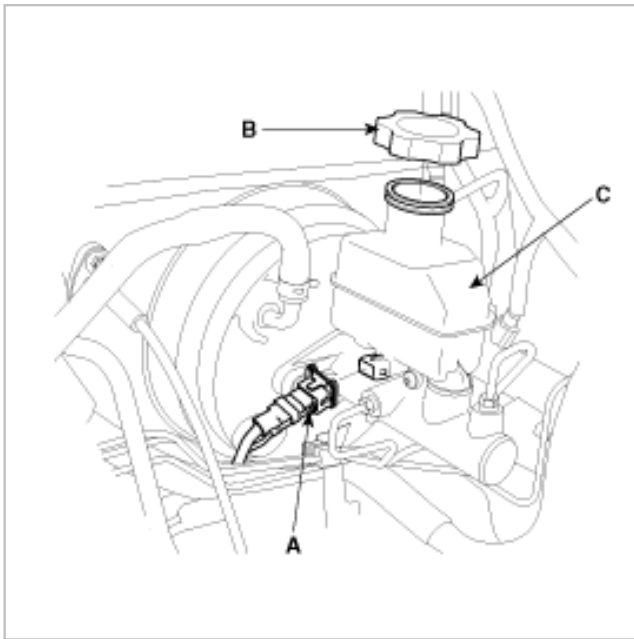

3. Remove the brake fluid from the master cylinder reservoir(C) with a syringe.
4. Disconnect the brake lines(A) from the master cylinder. To prevent spills, cover the hose joints with rags or shop towels.

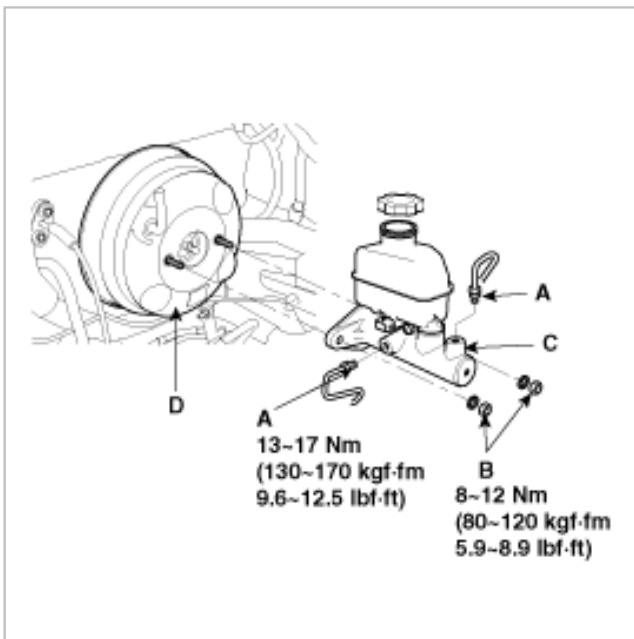

5. Remove the master cylinder mounting nuts(B) and washers.
6. Remove the master cylinder(C) from the brake booster(D). Be careful not to bend or damage the brake lines when removing the master cylinder.
7. Install the master cylinder in the reverse order of removal, and note these items:
A. Replace all rubber parts with new ones whenever, removed.

INSPECTION

- Before reassembling, check that all parts are free of dust and other foreign particles.
- Do not try to disassemble the master cylinder assembly. Replace the master cylinder assembly with a new part if necessary.
- Do not allow dirt or foreign matter to contaminate the brake fluid.

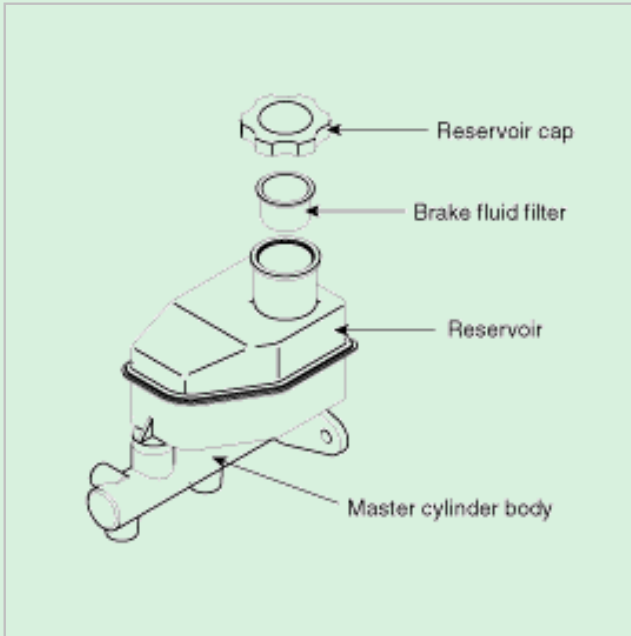

COMPONENTS

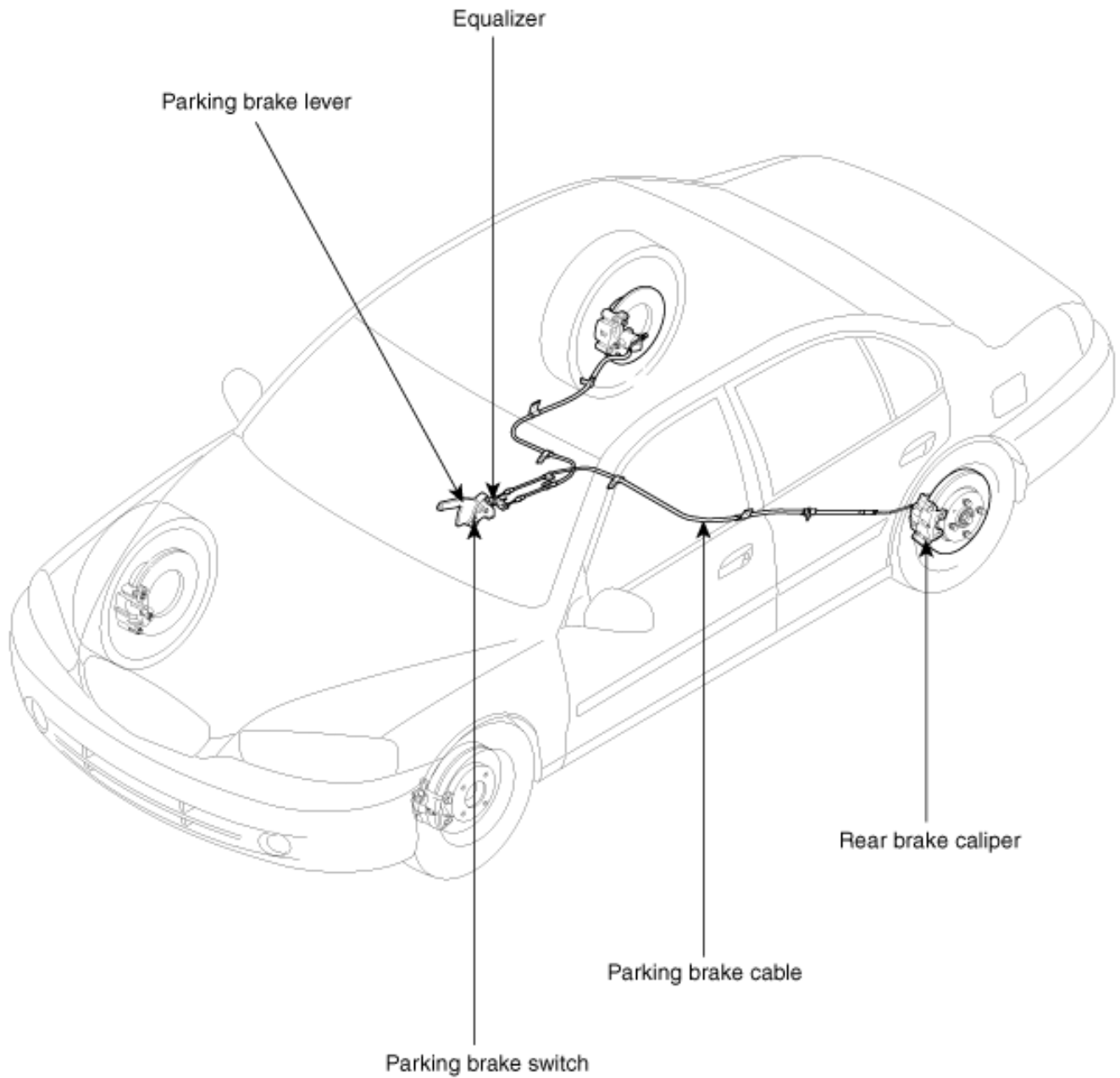

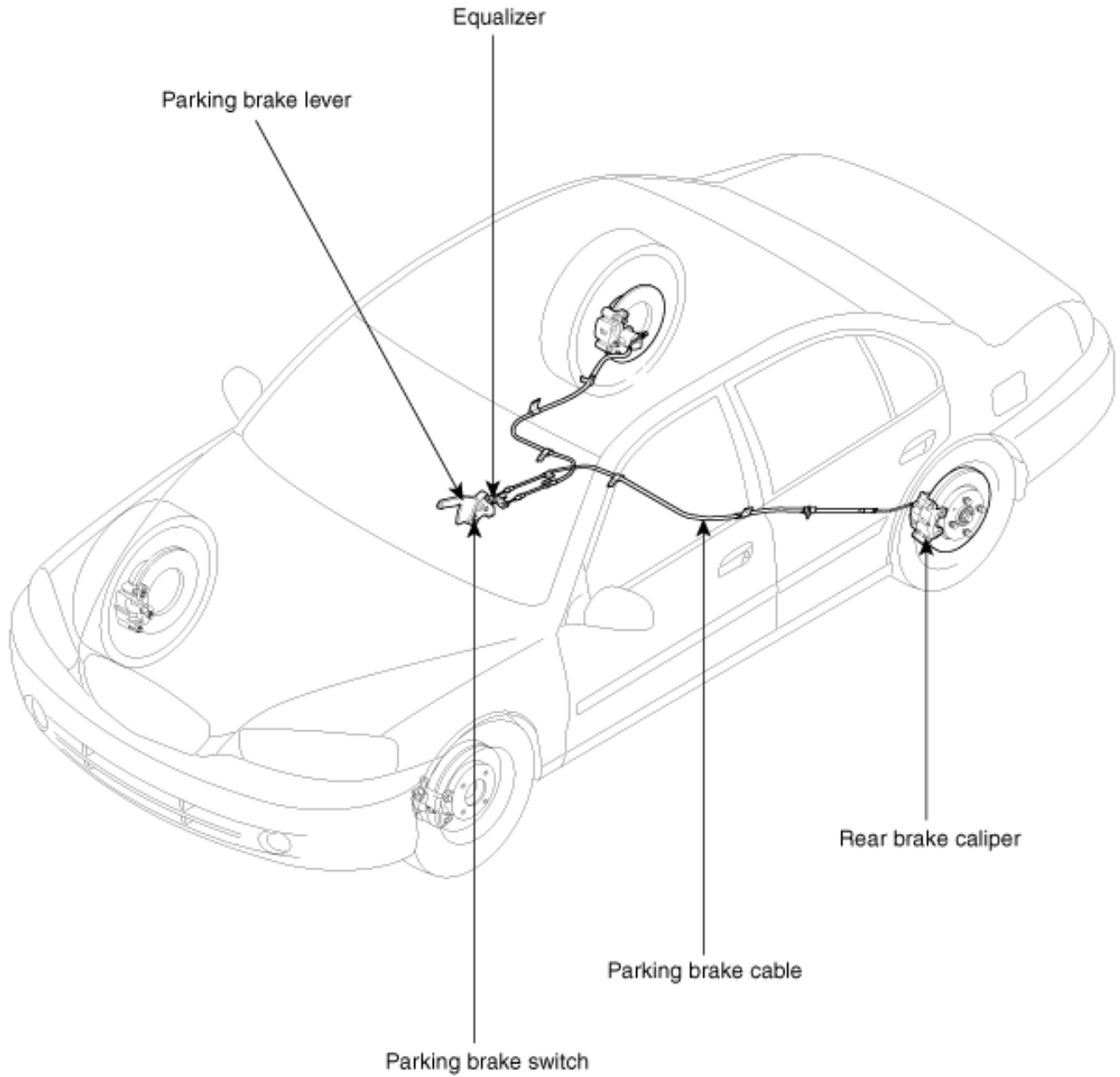

REMOVAL

NOTE

- The parking brake cables must not be bent or distorted. This will lead to stiff operation and premature failure.
- Refer to the component as needed during this procedure.

Rear disc brake

1. Release the parking brake lever fully, and remove the parking cable clip (A) from the parking brake cable.

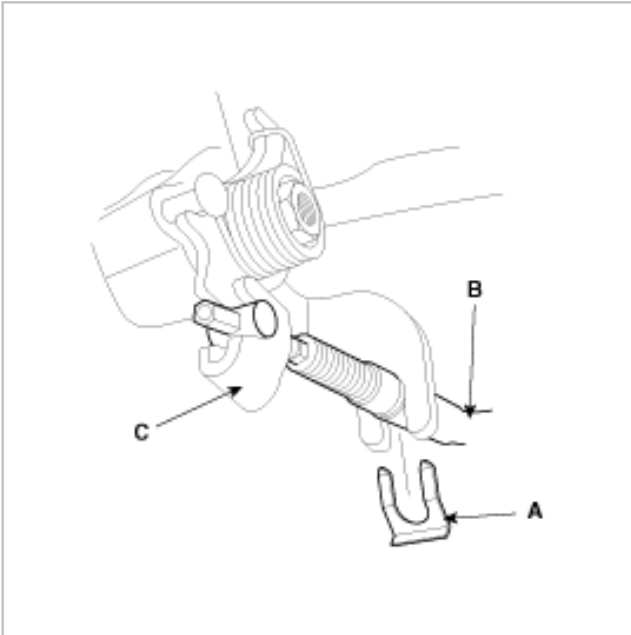

2. Disconnect the parking brake cable (B) from the lever (C).

Rear drum brake

1. Remove the brake shoe assembly (see page BR-39).
2. Remove the parking brake cable retaining (B), from the parking brake cable (A).

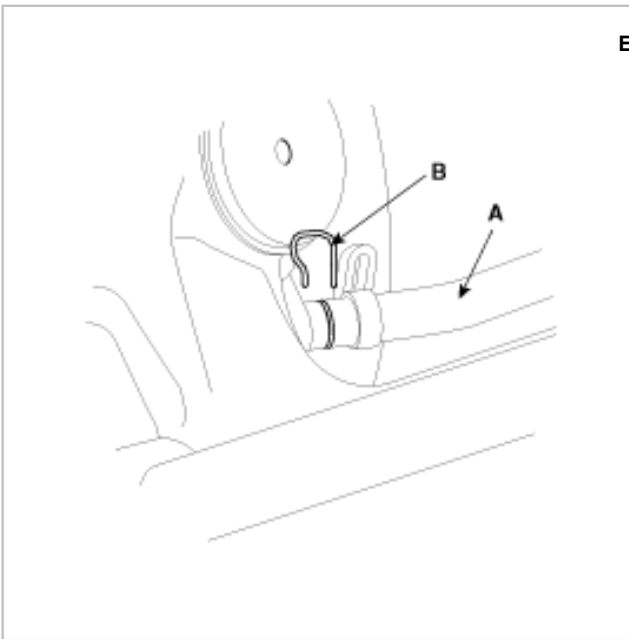

3. Remove the parking brake cable (A) from the backing plate (B).

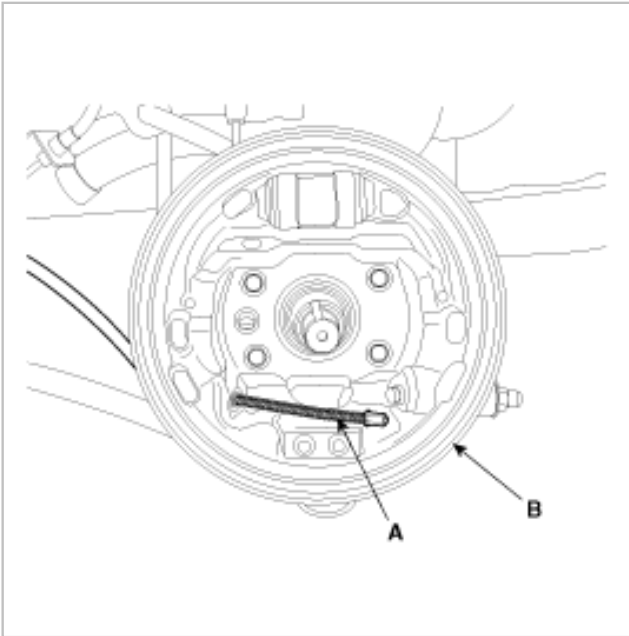

REMOVAL

NOTE

- The parking brake cables must not be bent or distorted. This will lead to stiff operation and premature failure.
- Refer to the component as needed during this procedure.

Rear disc brake

1. Release the parking brake lever fully, and remove the parking cable clip (A) from the parking brake cable.

Ebay User ID: reveleus1

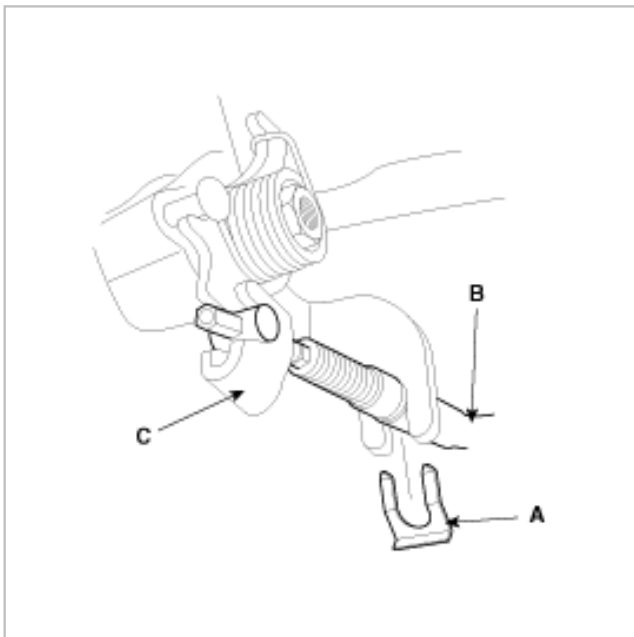

2. Disconnect the parking brake cable (B) from the lever (C).

Rear drum brake

1. Remove the brake shoe assembly (see page BR-39).
2. Remove the parking brake cable retaining (B), from the parking brake cable (A).

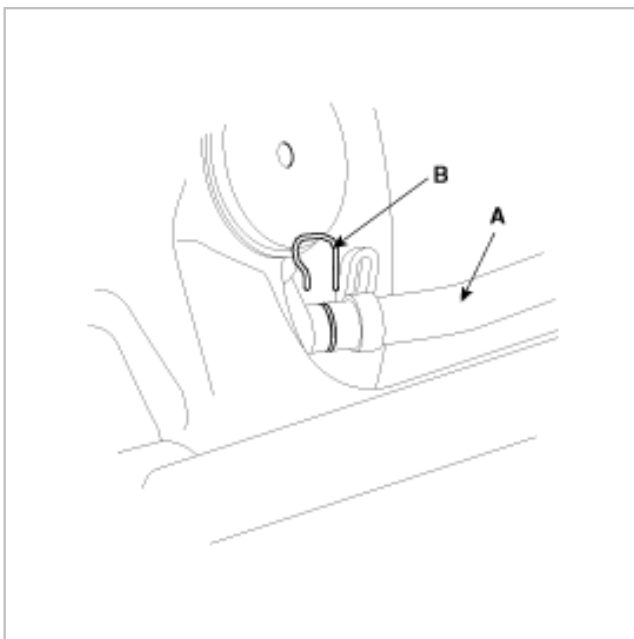

3. Remove the parking brake cable (A) from the backing plate (B).

Ebay User ID: reveleus1

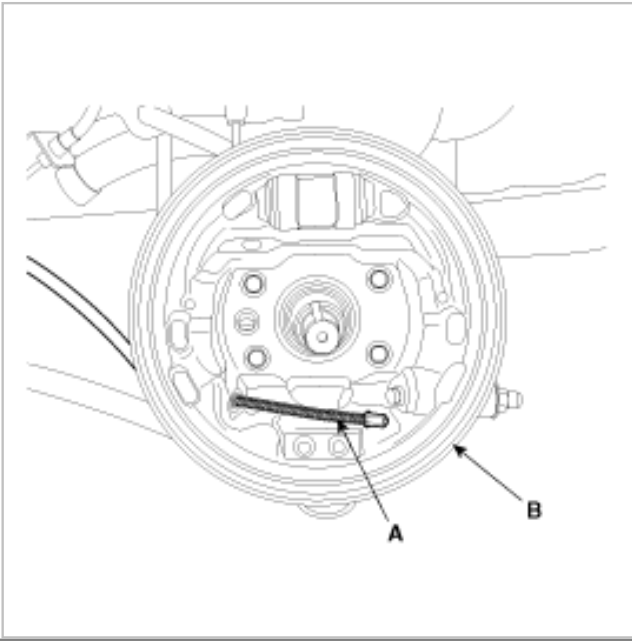

COMPONENT

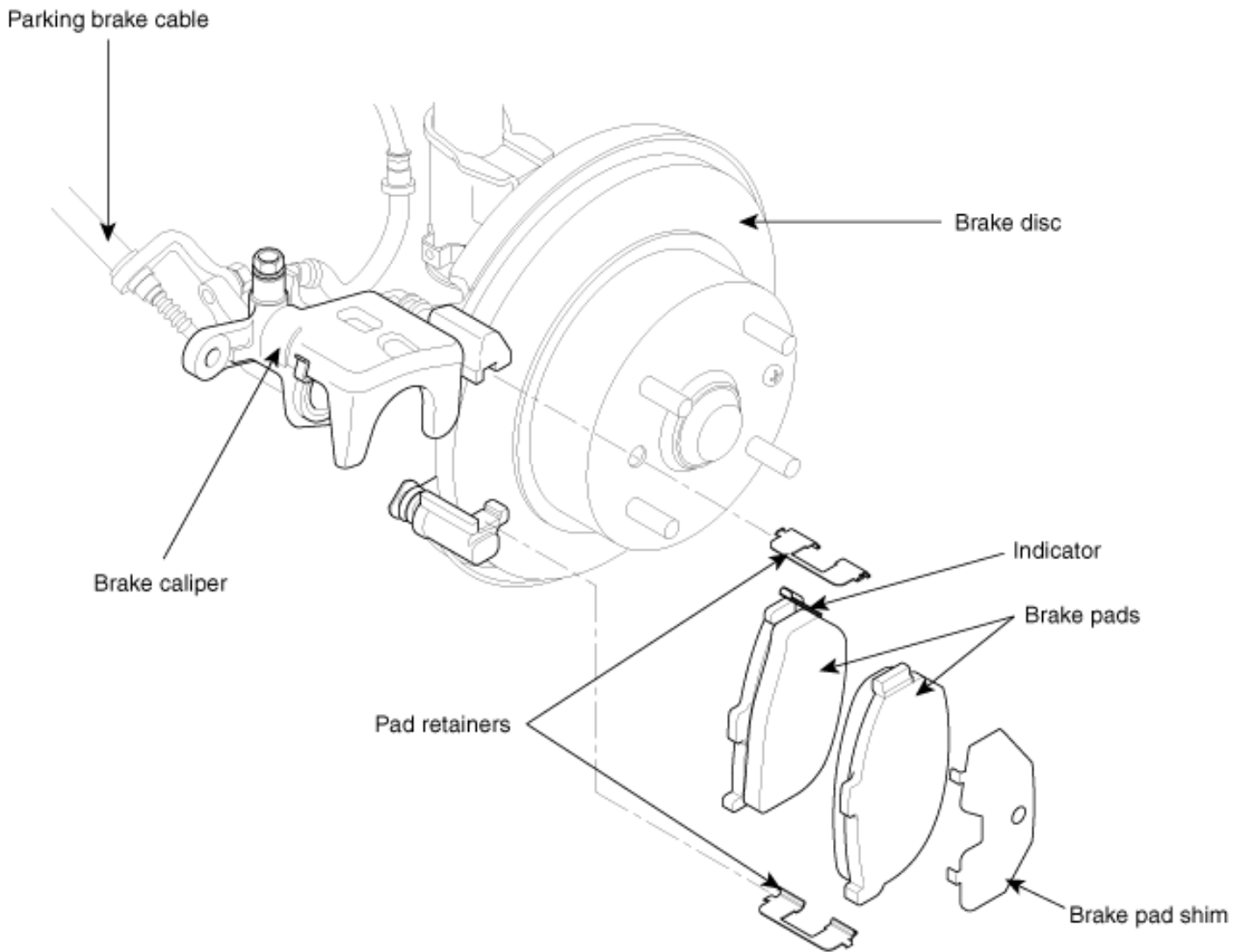

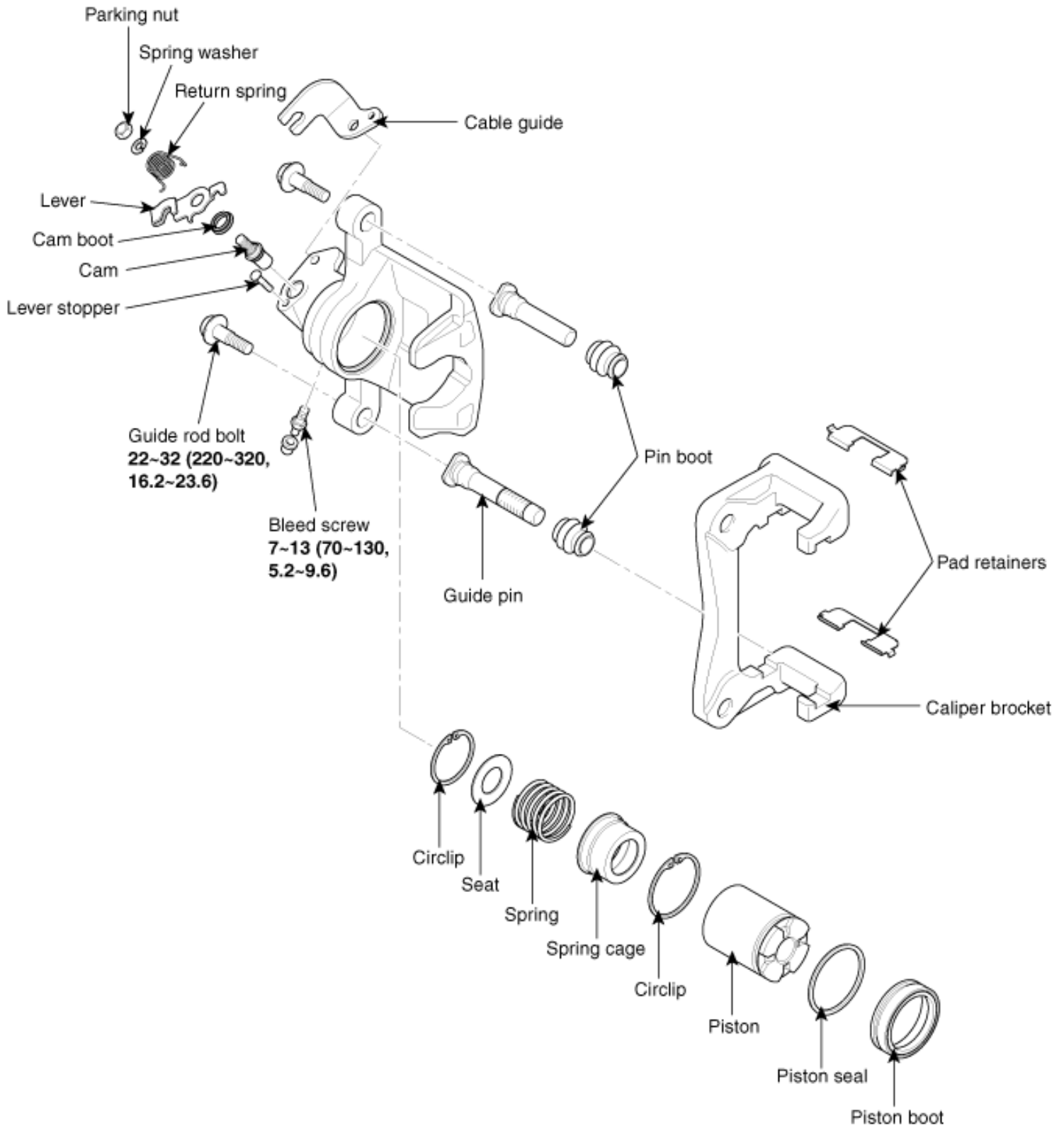

TORQUE: Nm (kgf-cm, lbf-ft)



General information

CAUTION

Frequent inhalation of brake pad dust, regardless of material composition, could be hazardous to your health.

- Avoid breathing dust particles.
- Never use an air hose or brush to clean brake assemblies.

Remove, disassemble, inspect, reassemble, and install the caliper and note these items:

- Do not spill brake fluid on the vehicle; it may damage the paint; If brake fluid gets on the paint, wash it off immediately with water.
- Clean all parts in brake fluid and air dry; blow out all passages with compressed air.
- Before reassembling, check that all parts are free of dirt and other foreign particles.
- Replace parts with new ones as specified in the illustration.
- Make sure no dirt or other foreign matter gets into the brake fluid.
- Make sure no grease or oil gets on the brake discs or pads.
- When reusing pads, always reinstall them in their original positions to prevent loss of braking efficiency.
- Do not reuse drained brake fluid.
- Always use Genuine DOT 3 or DOT 4 brake fluid. Non Genuine DOT 3 or DOT 4 brake fluid cause corrosion and shorten the life of the system.
- Coat the piston, piston seal groove, and caliper bore with clean brake fluid.
- Replace all rubber parts with new ones.
- After installing the caliper, check the brake hose and line for leaks, interference, interference, and twisting.

REPLACEMENT

CAUTION

Frequent inhalation of brake pad dust, regardless of material composition, could be hazardous to your health.

- Avoid breathing dust particles.
- Never use an air hose or brush to clean brake assemblies.

1. Raise the rear of the vehicle and make sure it is securely supported. Remove the rear wheel.
2. Release the parking brake.
3. Remove the brake hose (A) from the suspension arm by removing the brake hose clip (B). Thoroughly clean the outside of the caliper to prevent dust and dirt from entering inside. Support the caliper with a piece of wire so that it does not hang from the brake hose.

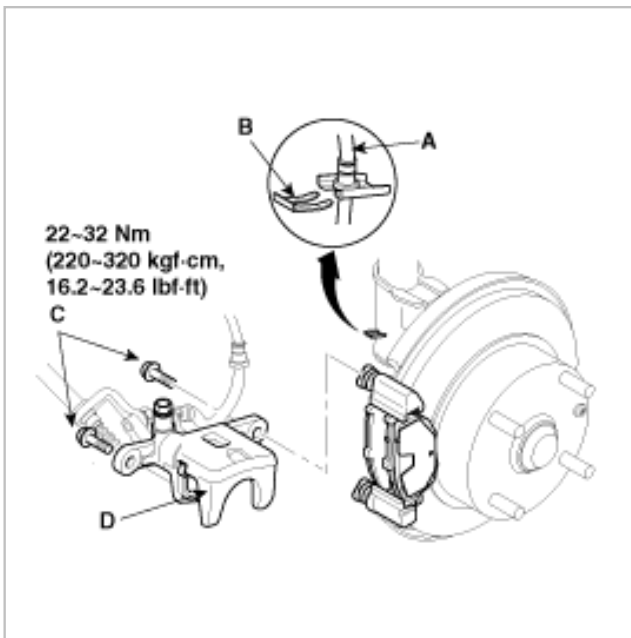

4. Remove the two guide rods (C) and caliper (D) from the bracket.
5. Remove the pad shim (A) and brake pads (B).

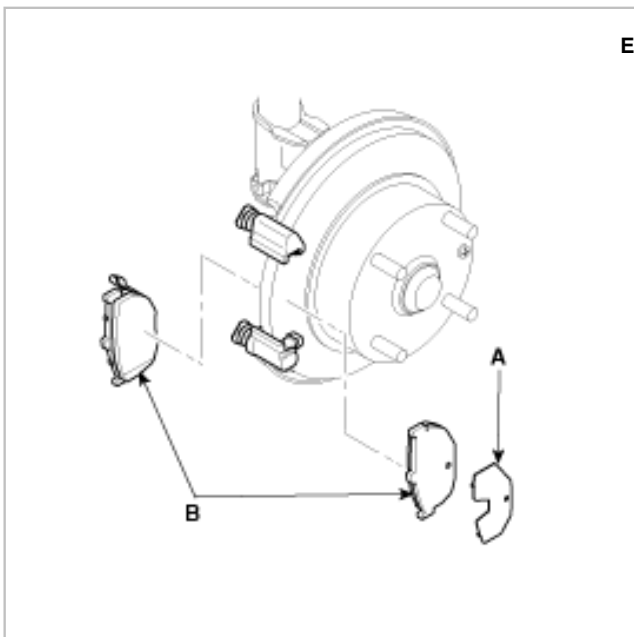

6. Using vernier calipers, measure the thickness of each brake pad lining. Measurement does not include pad backing plate (A) thickness.

Brake pad thickness:

9 mm (0.35 in.)

2 mm (0.08 in.)

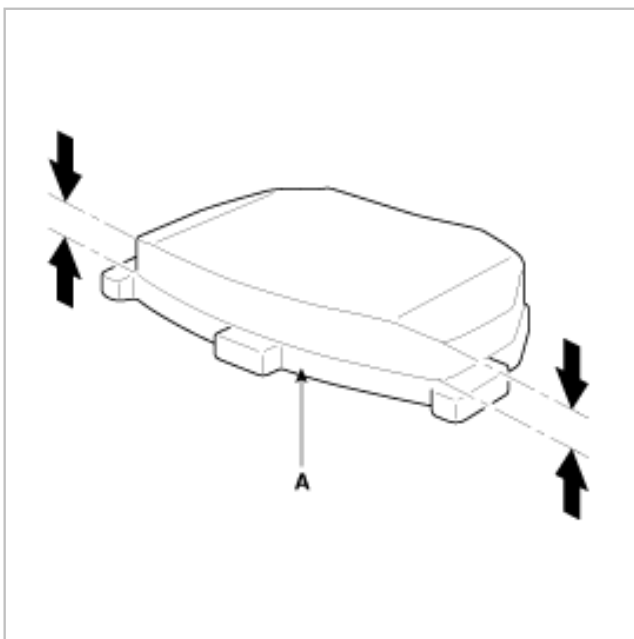

7. Remove the pad retainers.

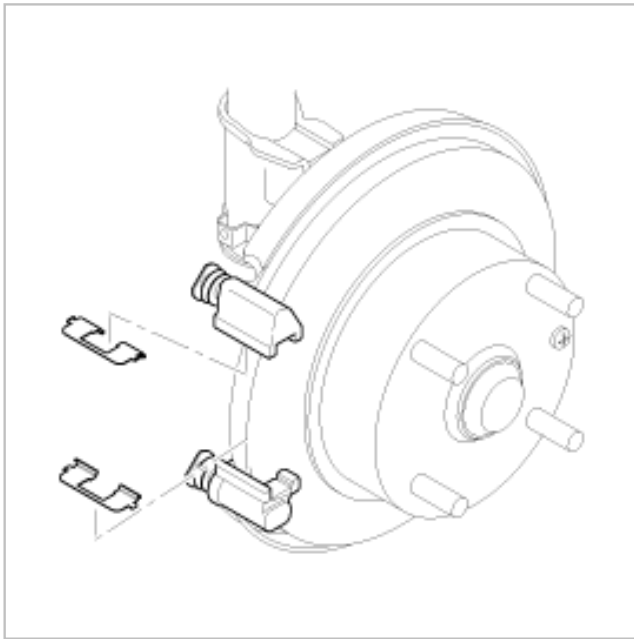

8. Clean the caliper thoroughly; remove any rust, and check for grooves and cracks.

9. Check the brake disc for damage and cracks.

10. Install the pad retainers.

11. Check the foreign material at the pad shim (A) and the back of the pads (B).

Contaminated brake discs or pads reduce stopping ability. Keep grease off the discs and pads.

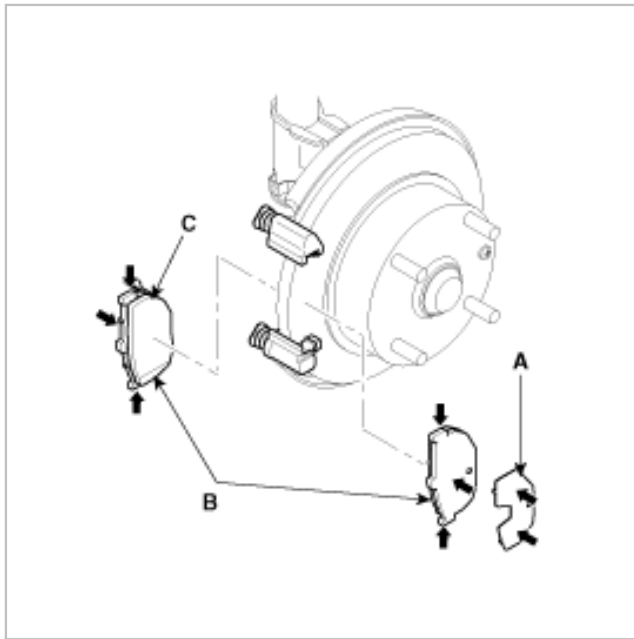

12. Install the brake pads (B) and pad shim (A) on the caliper bracket. Install the inner pad with its wear indicator (C) facing down ward.

If you are reusing the pads, always reinstall the brake pads in their original positions to prevent a momentary loss of braking efficiency.

13. Rotate the caliper piston (A) clockwise into the cylinder, then align the cutout (B) in the piston with the tab (C) on the inner pad by turning the piston back. Lubricate the boot with rubber grease to avoid twisting the piston boot. If the piston boot is twisted, back it out so it is positioned properly.

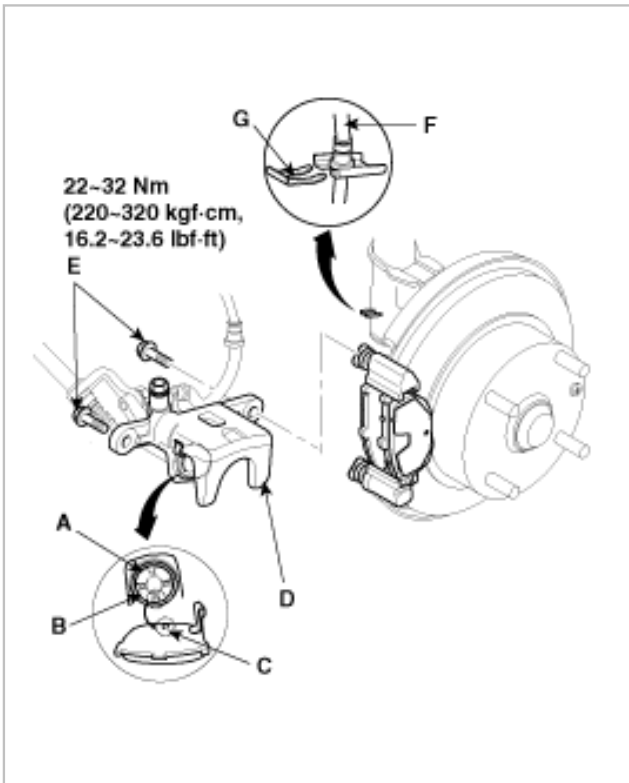

14. Install the brake caliper (D).
15. Install and torque the guide rods (E) to proper specification.
16. Install the brake hose (F) onto the suspension arm with the brake hose clip (G).
17. After installation, check for leaks at hose and line joints and connections, and retighten if necessary.
18. Depress the brake pedal several times to make sure the brakes work, then test-drive.

NOTE

Engagement of the brake may require a greater pedal stroke immediately after the brake pads have been replaced as a set. Several applications of the brake pedal will restore the normal pedal stroke.

INSPECTION

Runout

1. Raise the rear of the vehicle, and make sure it is securely supported.
2. Remove the brake pads (see page BR-33).
3. Inspect the disc surface for damage and cracks clean the disc thoroughly and remove all rust.

4. Use wheel nuts and suitable flat washers (A) to hold the disc securely against the hub, then mount a dial indicator (B) as shown, and measure the runout at 10 mm (0.4 in.) from the outer edge of the disc.

Ebay User ID: reveleus1

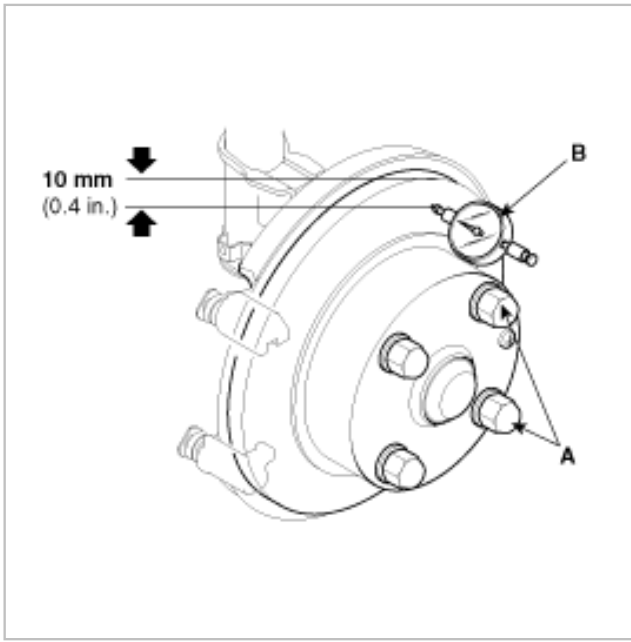

5. If the disc is beyond the service limit, refinish the brake disc.

8.0 mm (0.315 in.)

NOTE

A new disc should be refinished if its runout is greater than 0.10 mm (0.004 in.)

Thickness and parallelism

1. Loosen the rear wheel nuts slightly, then raise the vehicle, and make sure it is securely supported. Remove the rear wheels.
2. Remove the brak pads (see page BR-33).
3. Using a micrometer (A), measure disc thickness at eight points, approximately 45 apart and 10 mm (0.4 in.) in from the outer edge of the disc. Replace the brake disc if the smallest measurement is less than the max. refinishing limit.

Brake disc thickness:

10 mm (0.4 in.)

8.0 mm (0.315 in.)

Max. 0.015 mm (0.0006 in.)

This is the maximum allowable difference between the thickness measurements.

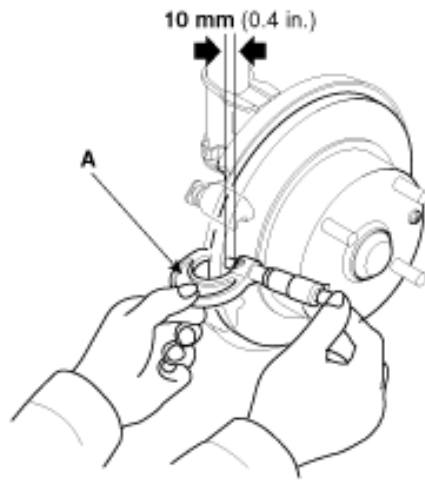

4. If the disc is beyond the service limit for parallelism, refinish the brake disc.

NOTE

If the brake disc is beyond the service limit for refinishing, replace it (see DS group-rear axle).

COMPONENTS

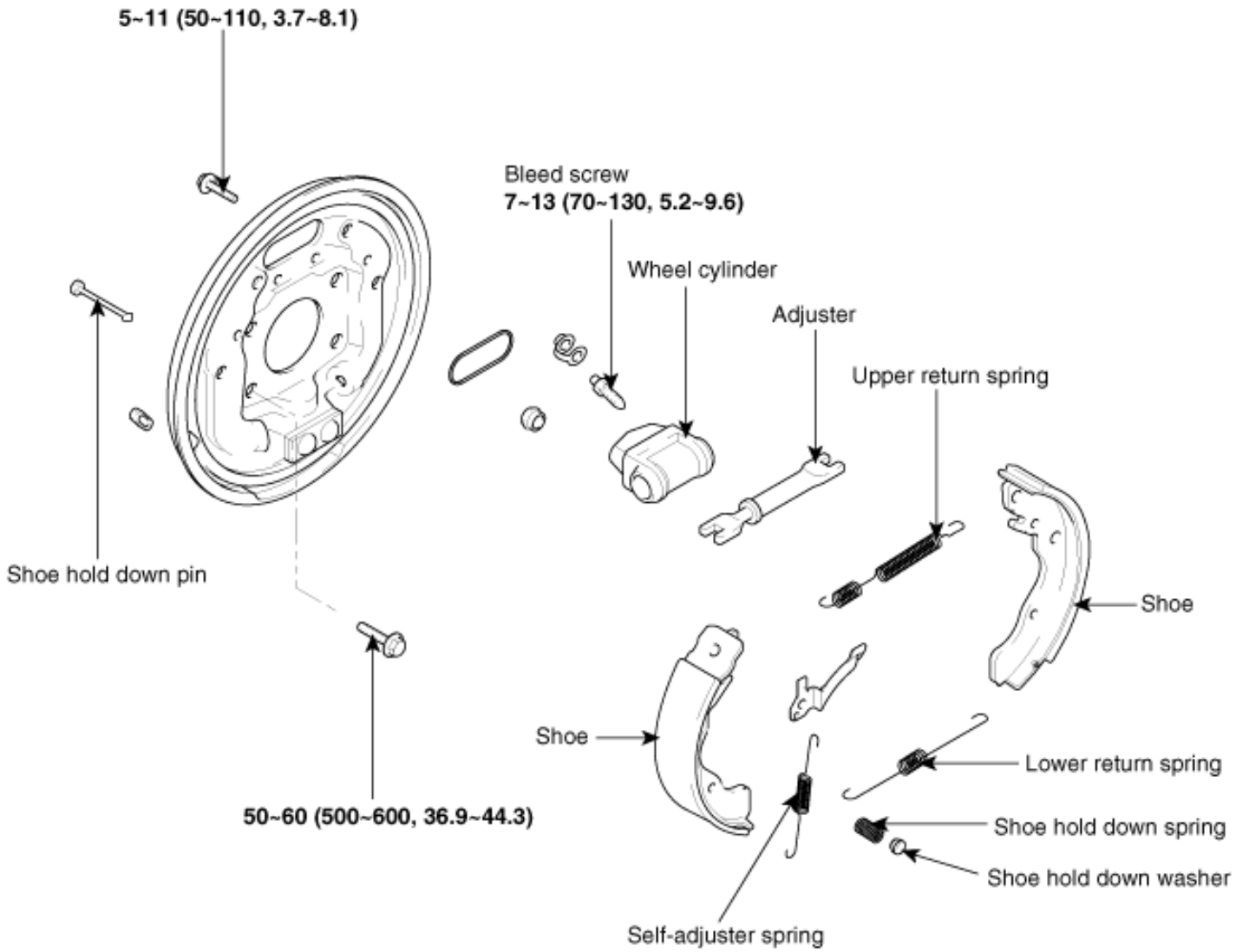

TORQUE: Nm (kgf-cm, lbf-ft)



INSPECTION

CAUTION

Frequent inhalation of brake pad dust, regardless of material composition, could be hazardous to your health.

- Avoid breathing dust particles.
- Never use an air hose or brush to clean brake assemblies.

NOTE

- Contaminated brake linings or drums reduce stopping ability.
- Block the front wheels before jacking up the rear of the vehicle.

1. Raise the rear of the vehicle, and make sure it is securely supported.
2. Release the parking brake, and remove the rear brake drum (see page BR-39).
3. Check the wheel cylinder (A) for leakage.

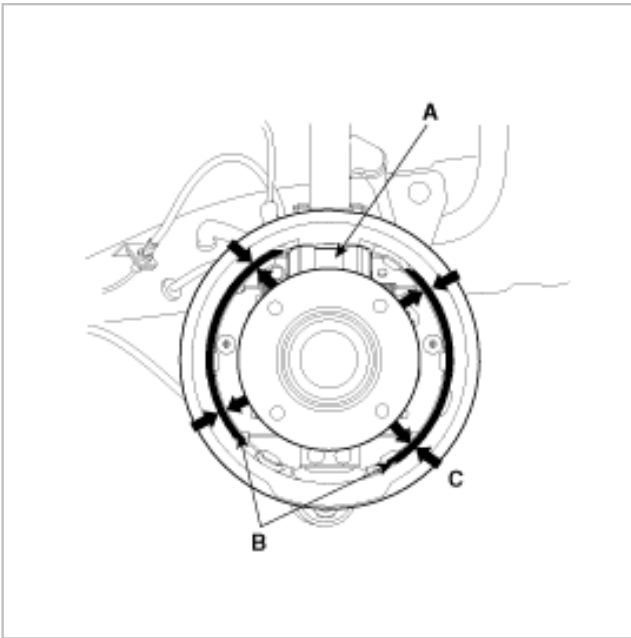

4. Check the brake linings (B) for cracking, glazing, wear, and contamination.
5. Measure the brake lining thickness (C).
Measurement does not include brake shoe thickness.

Brake lining thickness:

4.5 mm (0.177 in.)
1.0 mm (0.039 in.)

6. If the brake lining thickness is less than the service limit, replace the brake shoes as a set.
7. Check the bearings in the hub unit for smooth operation. If it requires servicing, replace it.

8. Measure the inside diameter of the brake drum with inside vernier calipers. Drum inside diameter:

Ebay User ID: reveleus1

Drum inside diameter:

203.2 mm (8 in.)

205.2 mm (8.079 in.)

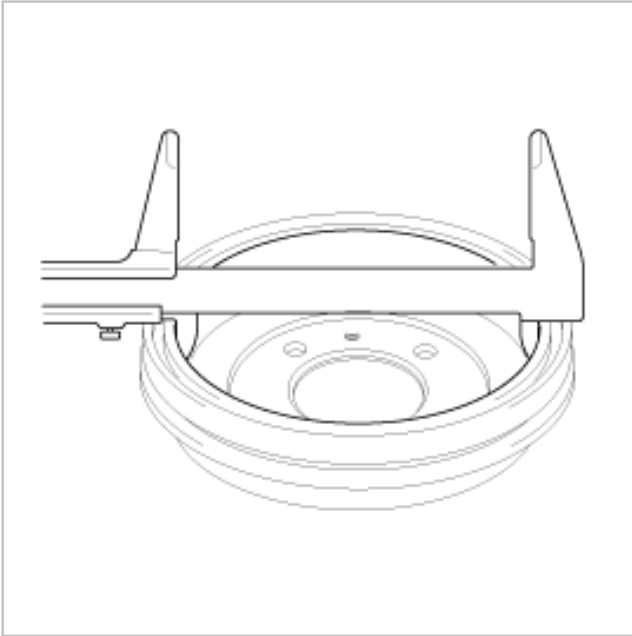

9. If the inside diameter of the brake drum is more than the service limit, replace the brake drum.

10. Check the brake drum for scoring, grooves, and cracks.

REPLACEMENT

Rear brake shoes

CAUTION

Frequent inhalation of brake pad dust, regardless of material composition, could be hazardous to your health.

- Avoid breathing dust particles
- Never use an air hose or brush to clean brake assemblies.

1. Disengage the upper return spring (A).

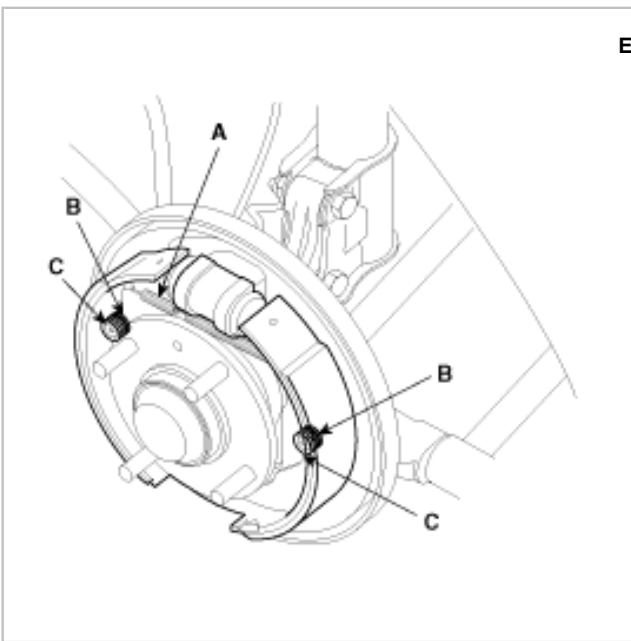

2. Remove the shoe hole down pins (B) by pushing the shoe hole down washer (C) and turning them.
3. Lower the brake shoe assembly (A), and remove the lower return spring (B). Make sure not to damage the dust cover on the wheel cylinder.

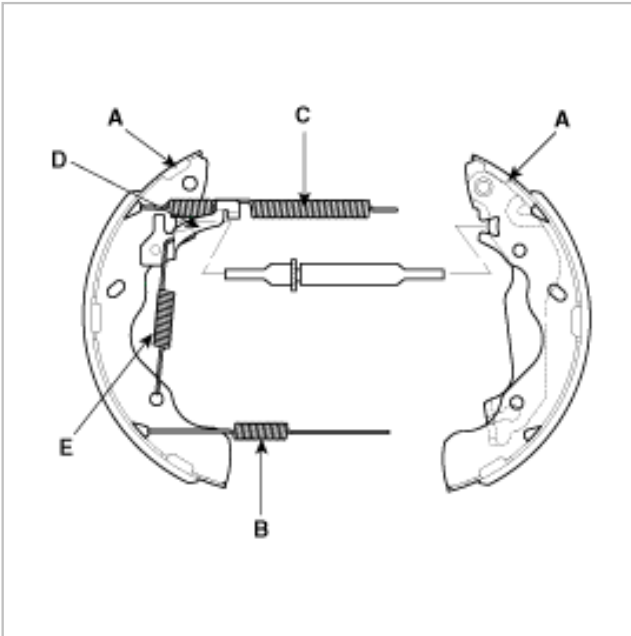

4. Disconnect the parking brake cable from the parking brake lever.
5. Remove the brake shoe assembly.
6. Remove the upper return spring (C), self-adjuster lever (D) and self-adjuster spring (E), and separate the brake shoes.
7. Connect the parking brake cable to the parking brake lever.

8. Clean the threaded portions of adjuster sleeve (A) and push rod female (B). Coat the threads of the adjuster assembly with grease (Castrol grease K764).
Ebay User ID: reveleus1

To shorten the clevises, turn the adjuster bolt (C).

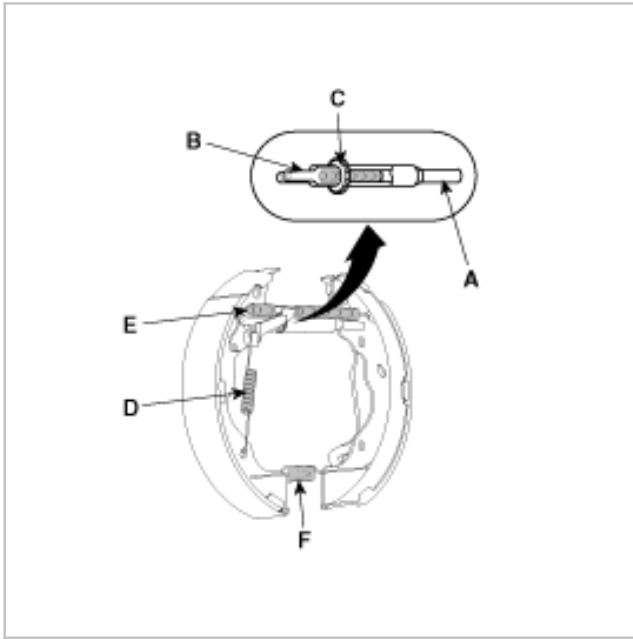

9. Hook the self-adjuster spring (D) to the adjuster lever first, then to the brake shoe.

10. Install the adjuster assembly and upper return spring (E), noting the installation direction. Be careful not to damage the wheel cylinder dust covers.

11. Install the lower return spring (F).

12. Apply brake cylinder grease or equivalent rubber grease to the sliding surfaces shown. Wipe off any excess, Don't get grease on the brake linings.

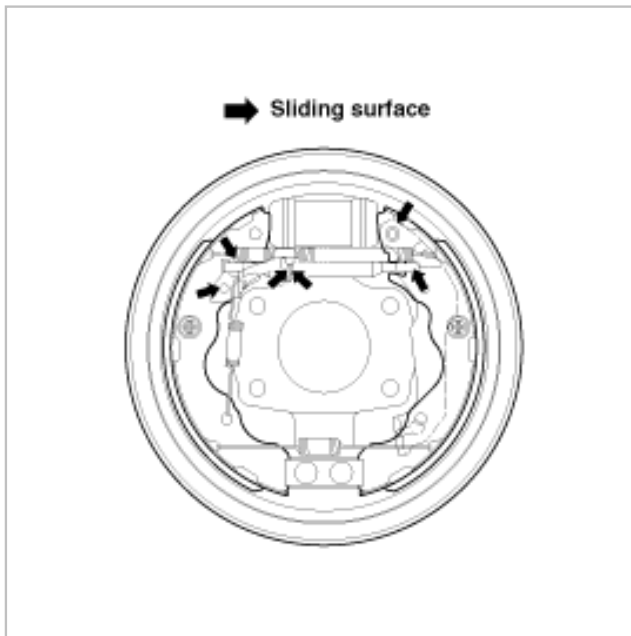

13. Apply Nyogel 744MS to the brake shoe ends and opposite edges of the shoes shown. Wipe off any excess. Don't get grease on the brake linings.

Ebay User ID: reveleus1

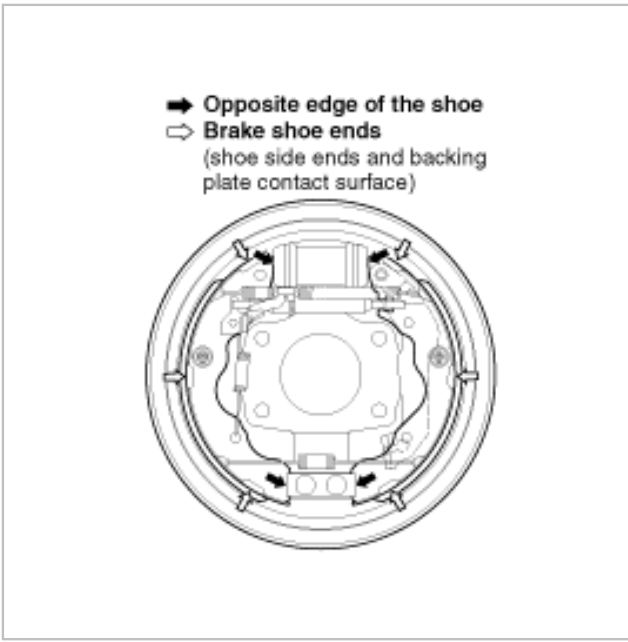

14. Install the brake shoes (A) onto the backing plate. Be careful not to damage the wheel cylinder dust covers.

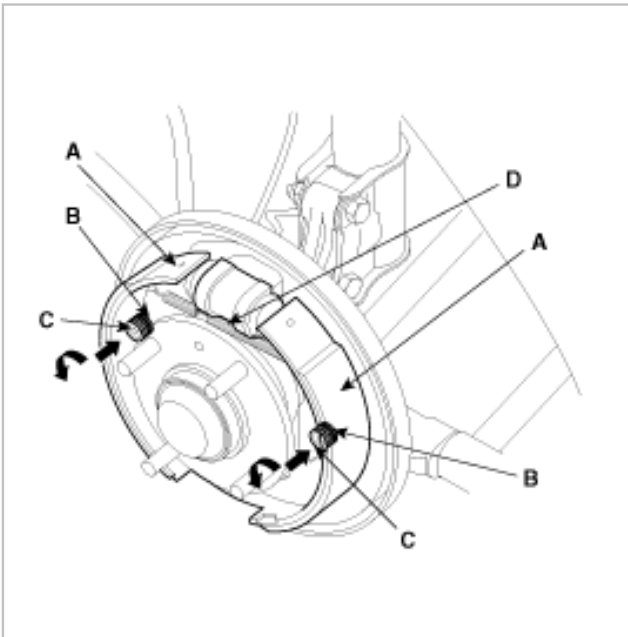

15. Install the shoe hole down pins (B) and the shoe hole down washers (C).
16. Hook the upper return spring (D).
17. Install the brake drum.
18. If the wheel cylinder has been removed, bleed the brake system (see page BR-12).
19. Depress the brake pedal several times to set the self-adjusting brake.
20. Adjust the parking brake (see page BR-11).

Rear wheel cylinder

- Do not spill brake fluid on the vehicle: it may damage the paint; if brake fluid does contact the paint. Wash it off immediately with water.
- To prevent spills, cover the hose joints with rags or shop towels.
- Use only a genuine wheel cylinder special bolt.

1. Remove the brake shoes (see page BR-39).
2. Disconnect the brake line (A) from the wheel cylinder (B).

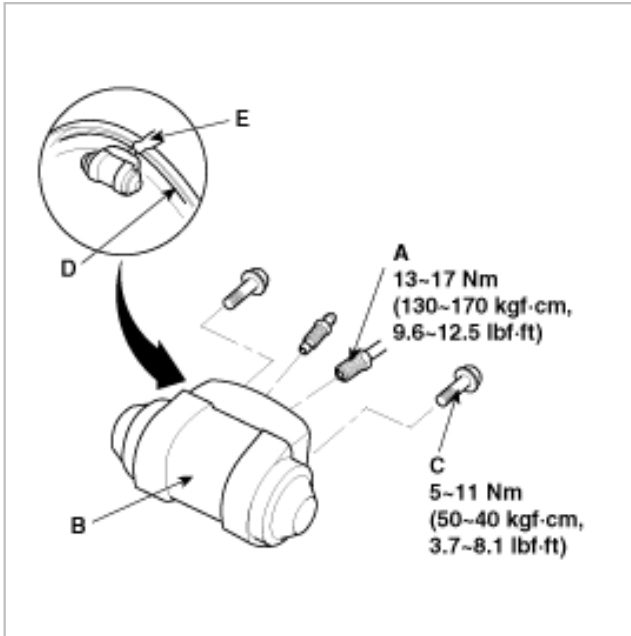

3. Remove the bolt (C) and the wheel cylinder from the backing plate.
4. Apply sealant (E) between the wheel cylinder (B) and backing plate (D), and install the wheel cylinder.
5. Install the removed parts in the reverse order of removal.
6. Fill the brake reservoir up and, bleed the brake system (see page BR-12)
7. After installation, check for a leak at the line joint, and retighten if necessary.

Brake Pedal and Brake Switch Adjustment

Pedal Height

1. Disconnect the brake switch connector, loosen the brake switch locknut (A), and back off the brake switch (B) until it is no longer touching the brake pedal.
2. Lift up the carpet. At the insulator cutout, measure the pedal height (C) from the middle of the left-side center of the pedal pad (D).

135 mm (5.31 in.)

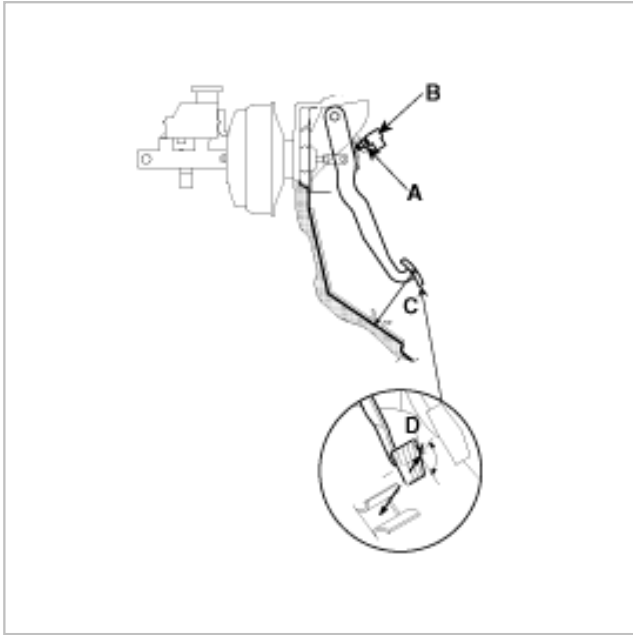

3. Loosen the pushrod locknut (A), and screw the pushrod in or out with pliers until the standard pedal height from the floor is reached. After adjustment, tighten the locknut firmly. Do not adjust the pedal height with the pushrod depressed.

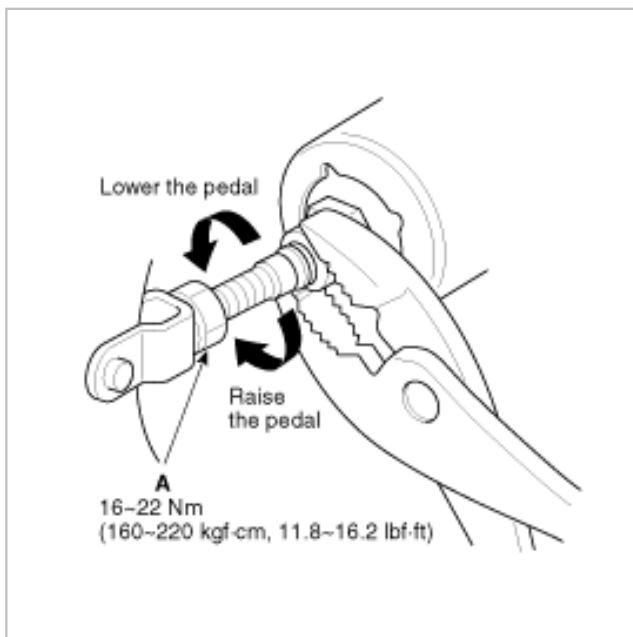

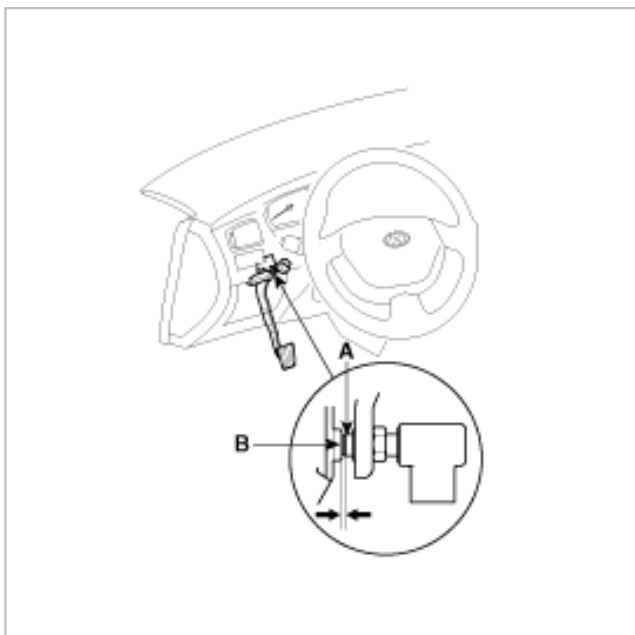
**Pedal Free Play**

1. With the engine off, inspect the pedal free play (A) on the pedal pad (B) by pushing the pedal by hand.

3~8 mm (0.11~0.31in.)

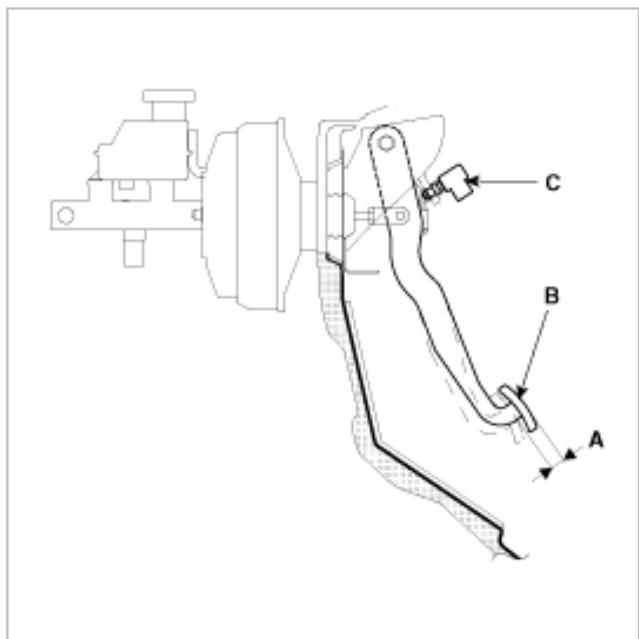

2. If the pedal free play is out of specification, adjust the brake switch (C). If the pedal free play is insufficient, it may result in brake drag.

Parking brake check and adjustment**Check**

1. Pull the parking brake lever (A) with 196 N (20 kgf, 44 lbf) force to fully apply the parking brake. The parking brake lever should be locked within the specified number of clicks (B)

Lever locked clicks:

Vehicle with rear disc brakes: 8~9

Vehicle with rear drum brakes: 8

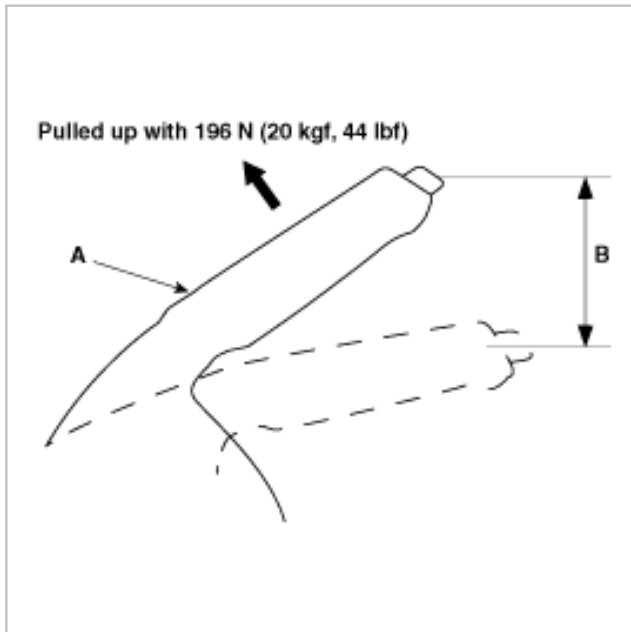

2. Adjust the parking brake if the lever clicks are out of specification.

ADJUSTMENT

NOTE

After rear brake caliper servicing, loosen the parking brake adjusting nut, start the engine and depress the brake pedal several times to set the self-adjusting brake before adjusting the parking brake.

1. Block the front wheels, then raise the rear of the vehicle and make sure it is securely supported.
2. Make sure the parking brake arm (A) on the rear brake caliper contacts the brake caliper pin (B).

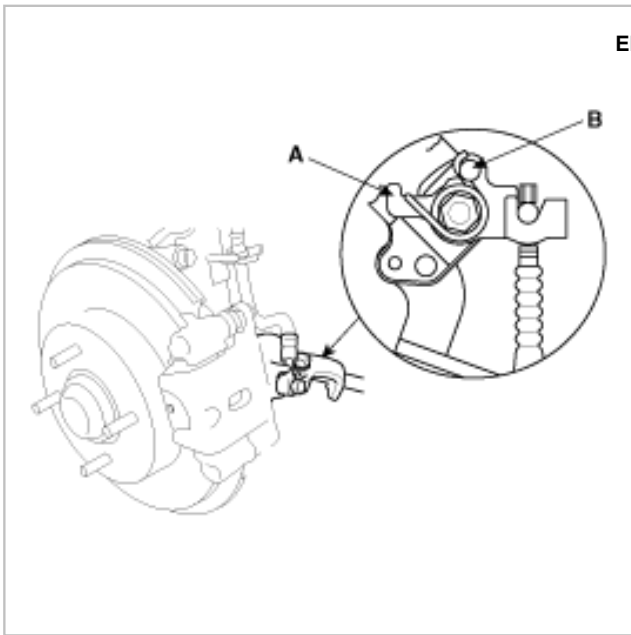

3. Pull the parking brake lever up one click.

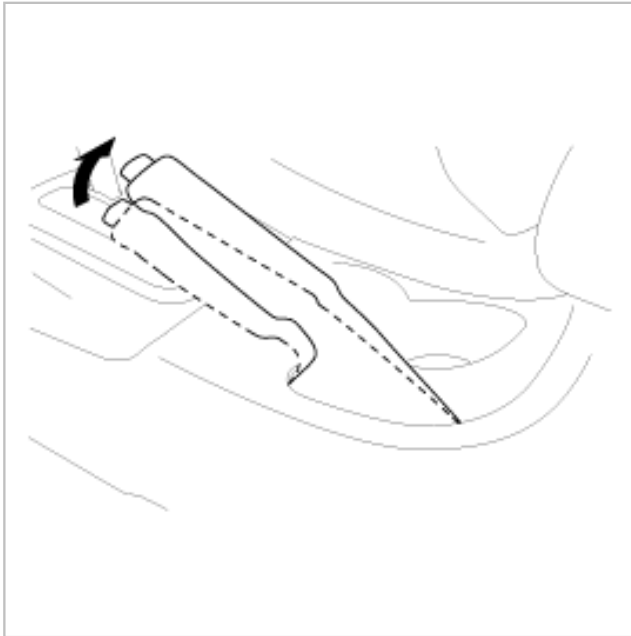

4. Remove the console (See page BD).

5. Tighten the adjusting nut (A) until the parking brakes drag slightly when the rear wheels are turned.

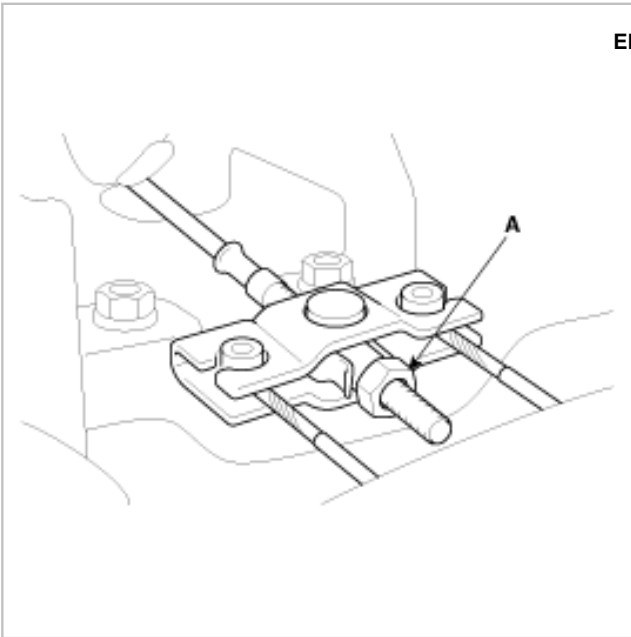

6. Release the parking brake lever fully, and check that parking brakes do not drag when the rear wheels are turned. Readjust if necessary.
7. Make sure that the parking brakes are fully applied when the parking brake lever is pulled up fully.
8. Reinstall the console.

Brake System Bleeding

NOTE

- Do not reuse the drained fluid.
- Always use Genuine DOT 3 or DOT 4 Brake Fluid. Using a non-Genuine DOT3 or DOT 4 brake fluid can cause corrosion and decrease the life of the system.
- Make sure no dirt or other foreign matter is allowed to contaminate the brake fluid.
- Do not spill brake fluid on the vehicle, it may damage the paint; if brake fluid does contact the paint, wash it off immediately with water.
- The reservoir on the master cylinder must be at the MAX (upper) level mark at the start of bleeding procedure and checked after bleeding each brake caliper. Add fluid as required.

1. Make sure the brake fluid level in the reservoir is at the MAX (upper) level line (A).

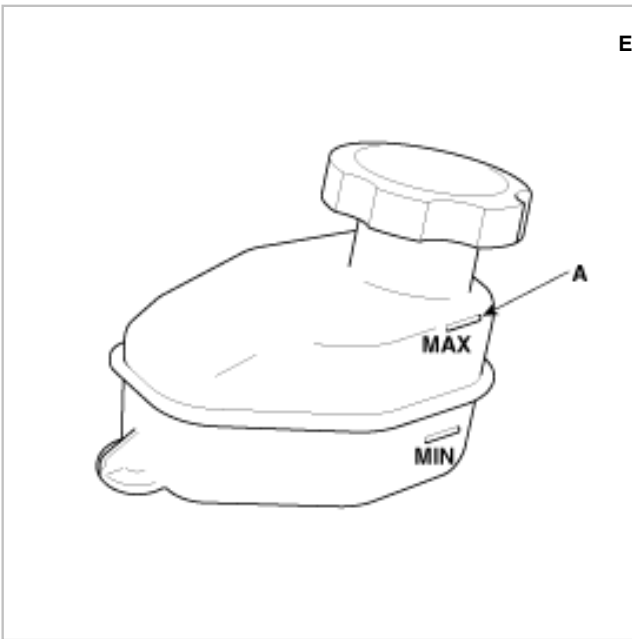

2. Have someone slowly pump the brake pedal several times, then apply steady pressure.
3. Loosen the right-rear brake bleed screw to allow air to escape from the system. Then tighten the bleed screw securely.
4. Repeat the procedure for each wheel in the sequence shown below until air bubbles no longer appear in the fluid.
5. Refill the master cylinder reservoir to the MAX (upper) level line.

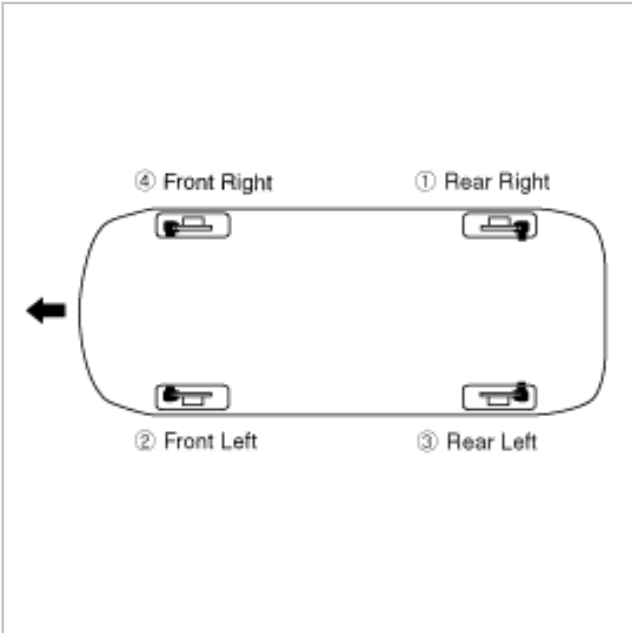

Front disc brake:

7-13 Nm (70-130 kgf-cm, 5.2-9.6 lbf-ft)

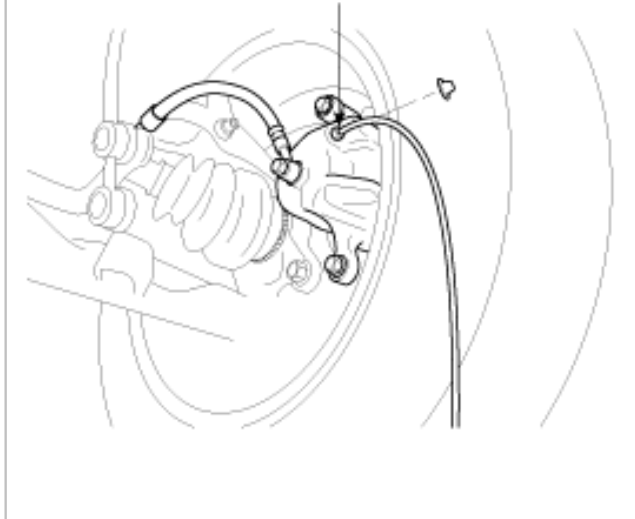

Rear disc brake:

7-13 Nm (70-130 kgf-cm, 5.2-9.6 lbf-ft)

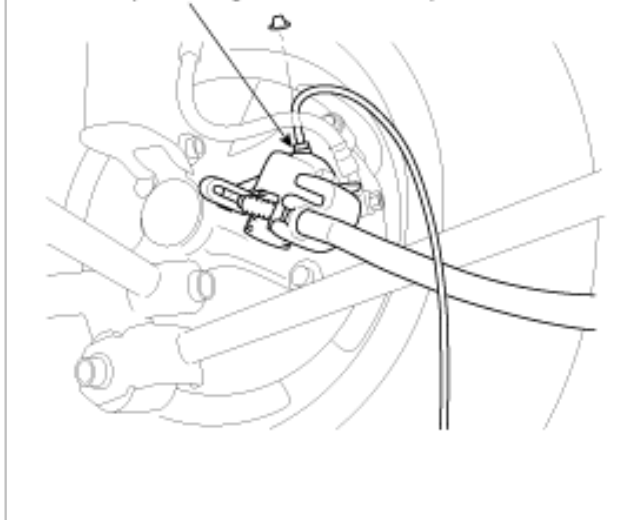

Rear drum brake:

7-13 Nm (70-130 kgf·cm, 5.2-9.6 lbf·ft)



Parking Brake Switch Test

1. Remove the rear console, and disconnect the connector (A) from the switch (B).

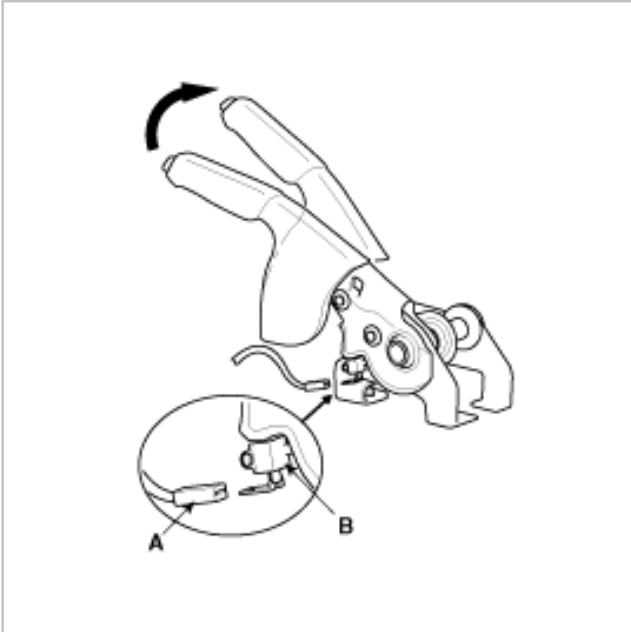

2. Check for continuity between the positive terminal and body ground:
 - A. With the brake lever up, there should be continuity.
 - B. With the brake lever down, there should be no continuity.

Brake Pedal and Brake Switch Adjustment

Pedal Height

1. Disconnect the brake switch connector, loosen the brake switch locknut (A), and back off the brake switch (B) until it is no longer touching the brake pedal.

2. Lift up the carpet. At the insulator cutout, measure the pedal height (C) from the middle of the left-side center of the pedal pad (D).

Ebay User ID: reveleus1

135 mm (5.31 in.)

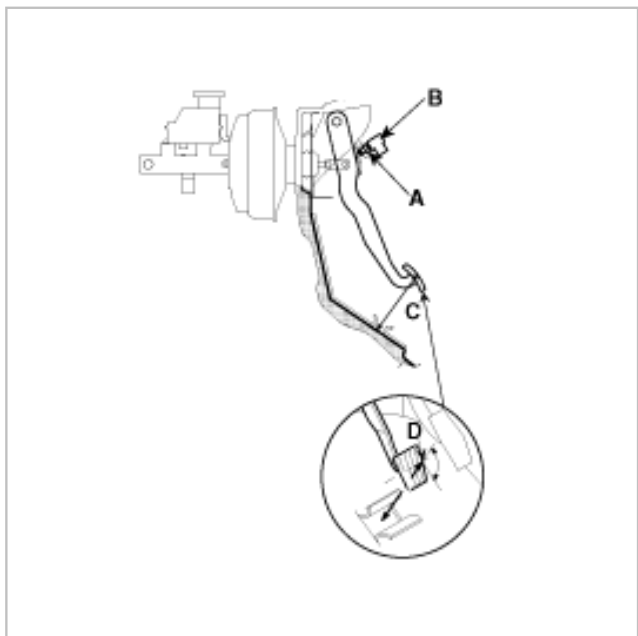

3. Loosen the pushrod locknut (A), and screw the pushrod in or out with pliers until the standard pedal height from the floor is reached. After adjustment, tighten the locknut firmly. Do not adjust the pedal height with the pushrod depressed.

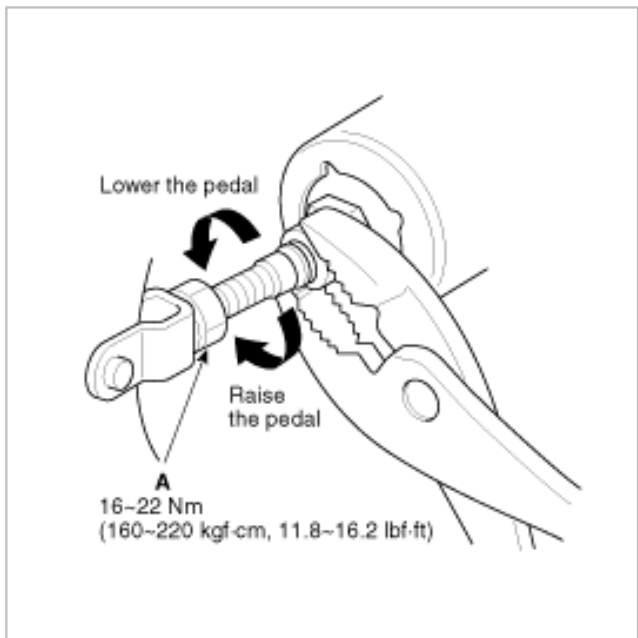

BRAKE SWITCH CLEARANCE

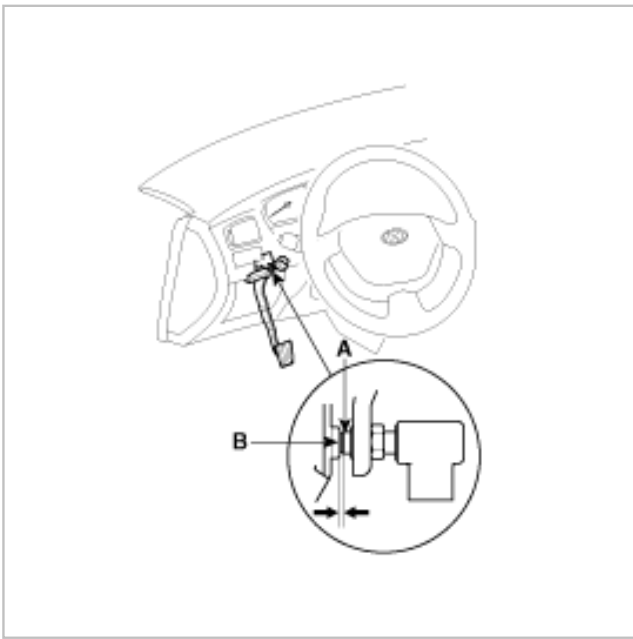

Pedal Free Play

1. With the engine off, inspect the pedal free play (A) on the pedal pad (B) by pushing the pedal by hand.

3~8 mm (0.11~0.31in.)

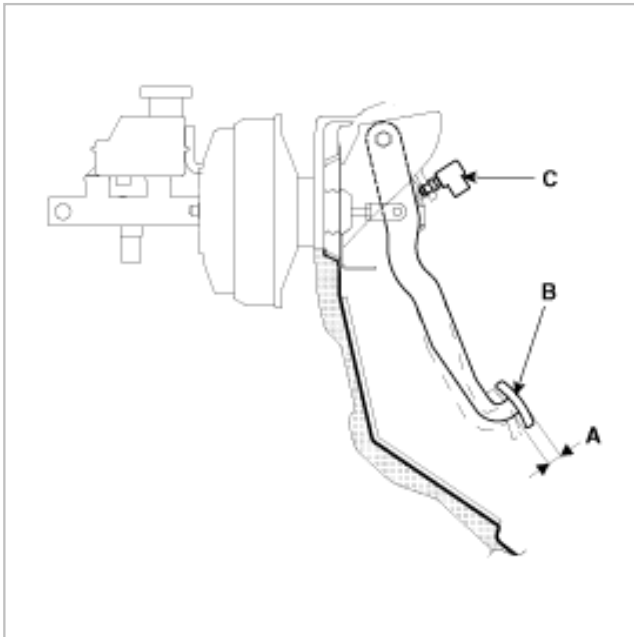

2. If the pedal free play is out of specification, adjust the brake switch (C). If the pedal free play is insufficient, it may result in brake drag.

Parking brake check and adjustment

Check

1. Pull the parking brake lever (A) with 196 N (20 kgf, 44 lbf) force to fully apply the parking brake. The parking brake lever should be locked within the specified number of clicks (B)

Lever locked clicks:

Vehicle with rear disc brakes: 8~9

Vehicle with rear drum brakes: 8

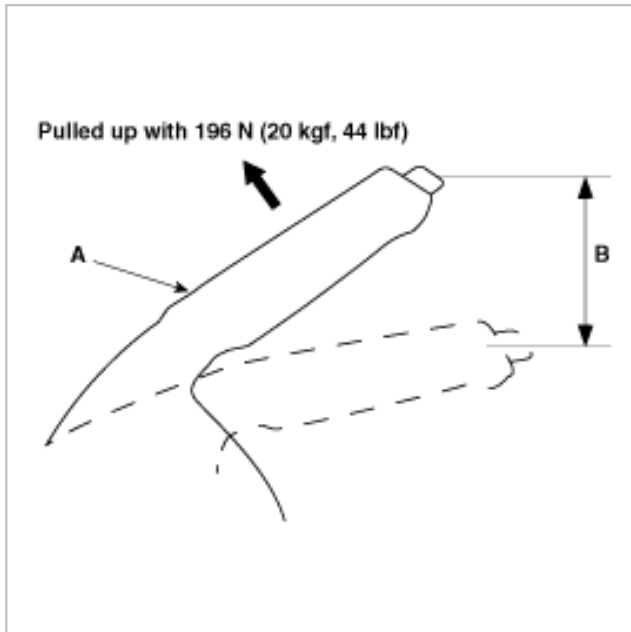

2. Adjust the parking brake if the lever clicks are out of specification.

ADJUSTMENT

NOTE

After rear brake caliper servicing, loosen the parking brake adjusting nut, start the engine and depress the brake pedal several times to set the self-adjusting brake before adjusting the parking brake.

1. Block the front wheels, then raise the rear of the vehicle and make sure it is securely supported.
2. Make sure the parking brake arm (A) on the rear brake caliper contacts the brake caliper pin (B).

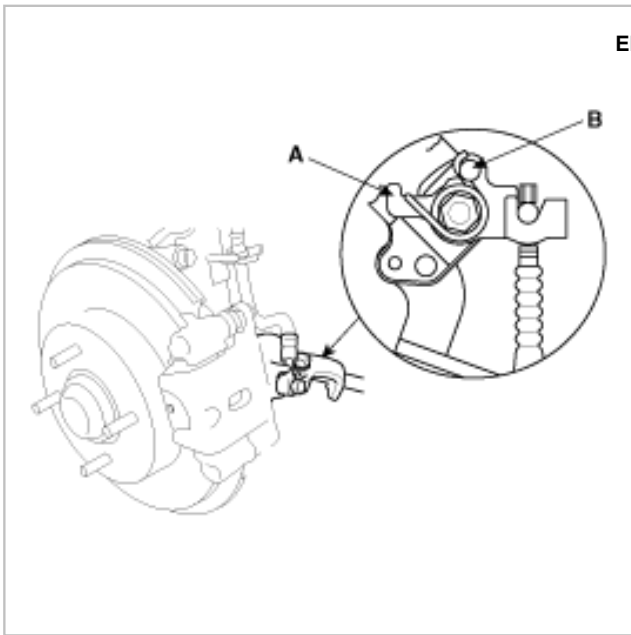

3. Pull the parking brake lever up one click.

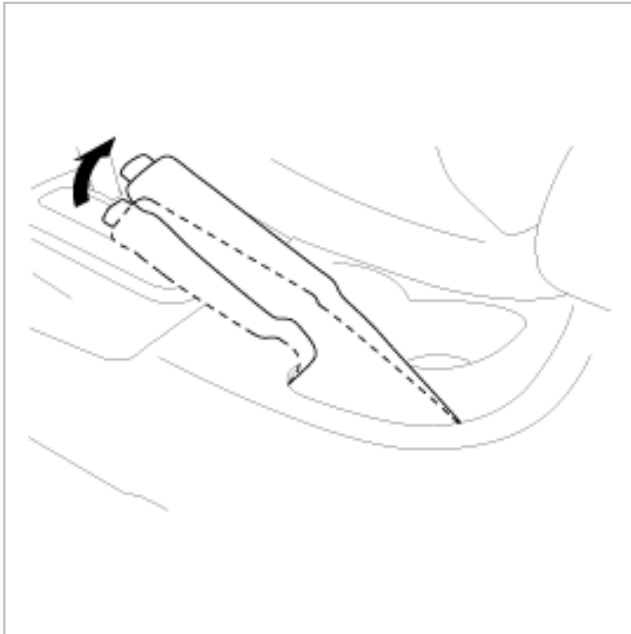

4. Remove the console (See page BD).

5. Tighten the adjusting nut (A) until the parking brakes drag slightly when the rear wheels are turned.

Purchased
from Ebay seller
Reveleus1

Thank-you for purchasing from me, it
is much appreciated.

To contact me please email
suzlever@gmail.com

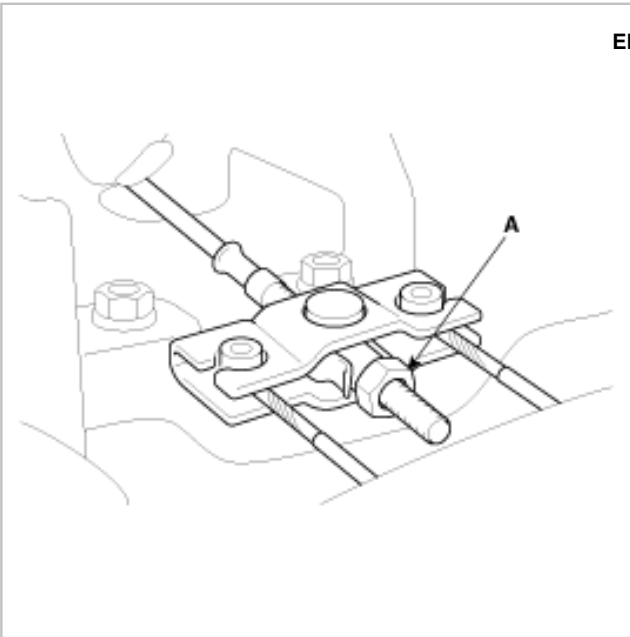

6. Release the parking brake lever fully, and check that parking brakes do not drag when the rear wheels are turned. Readjust if necessary.
7. Make sure that the parking brakes are fully applied when the parking brake lever is pulled up fully.
8. Reinstall the console.

Brake System Bleeding

NOTE

- Do not reuse the drained fluid.
- Always use Genuine DOT 3 or DOT 4 Brake Fluid. Using a non-Genuine DOT3 or DOT 4 brake fluid can cause corrosion and decrease the life of the system.
- Make sure no dirt or other foreign matter is allowed to contaminate the brake fluid.
- Do not spill brake fluid on the vehicle, it may damage the paint; if brake fluid does contact the paint, wash it off immediately with water.
- The reservoir on the master cylinder must be at the MAX (upper) level mark at the start of bleeding procedure and checked after bleeding each brake caliper. Add fluid as required.

1. Make sure the brake fluid level in the reservoir is at the MAX (upper) level line (A).

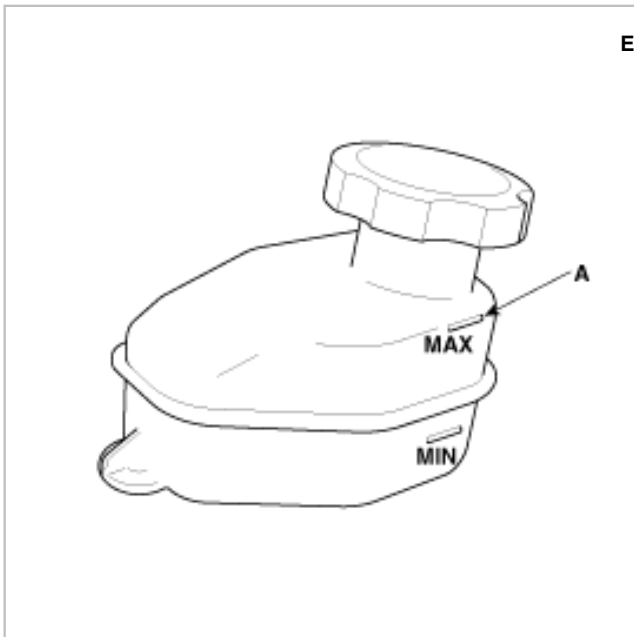

2. Have someone slowly pump the brake pedal several times, then apply steady pressure.
3. Loosen the right-rear brake bleed screw to allow air to escape from the system. Then tighten the bleed screw securely.
4. Repeat the procedure for each wheel in the sequence shown below until air bubbles no longer appear in the fluid.
5. Refill the master cylinder reservoir to the MAX (upper) level line.

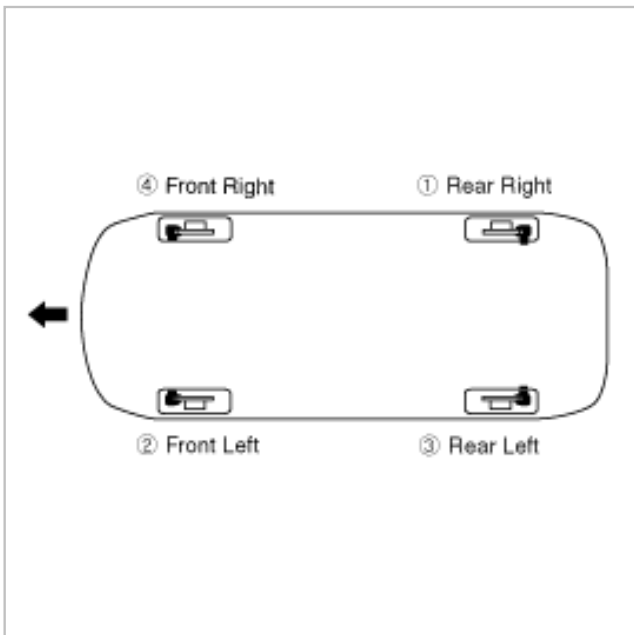

Front disc brake:

7-13 Nm (70-130 kgf-cm, 5.2-9.6 lbf-ft)

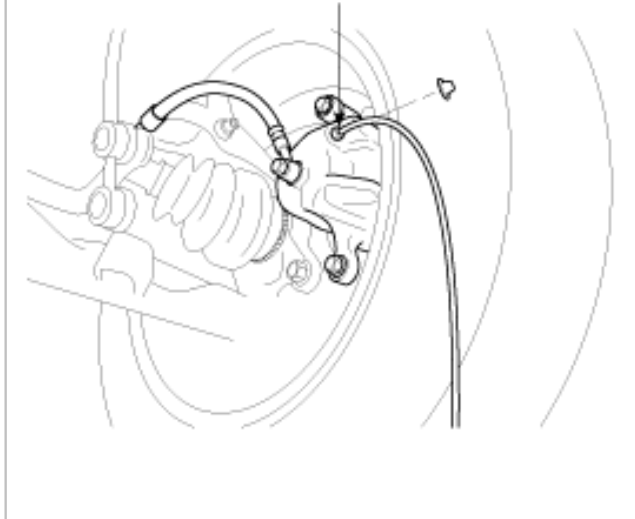

Rear disc brake:

7-13 Nm (70-130 kgf-cm, 5.2-9.6 lbf-ft)

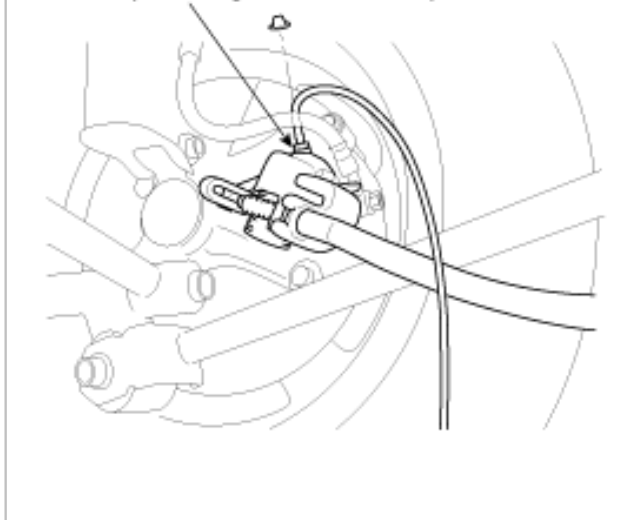

Rear drum brake:

7~13 Nm (70~130 kgf·cm, 5.2~9.6 lbf·ft)

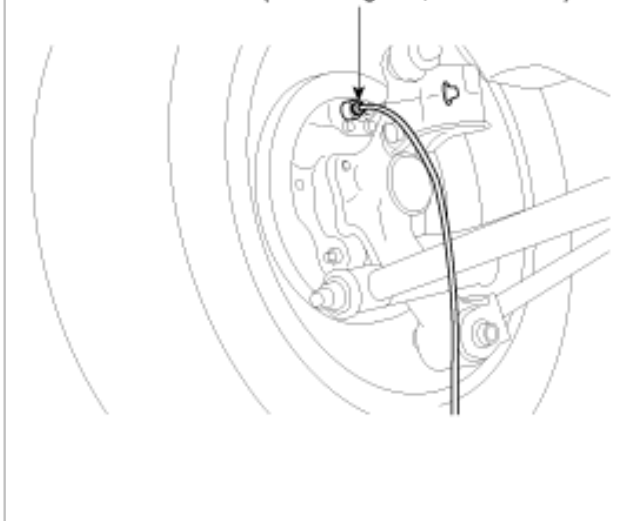

Parking Brake Switch Test

1. Remove the rear console, and disconnect the connector (A) from the switch (B).

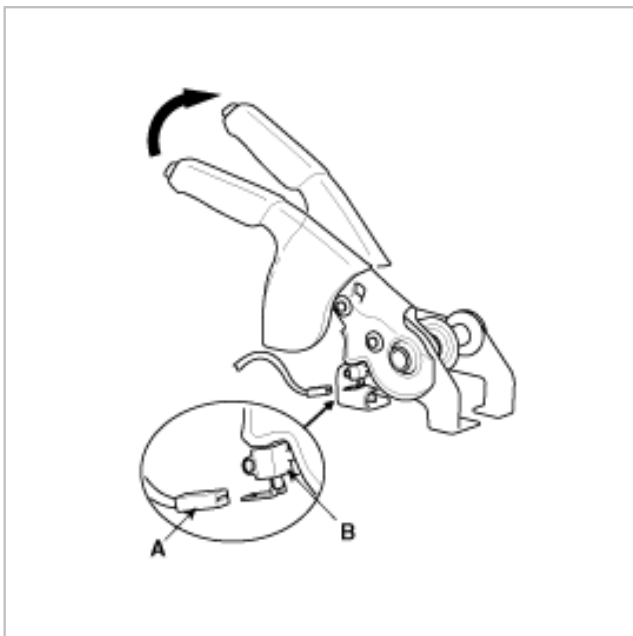

2. Check for continuity between the positive terminal and body ground:
A. With the brake lever up, there should be continuity.
B. With the brake lever down, there should be no continuity.

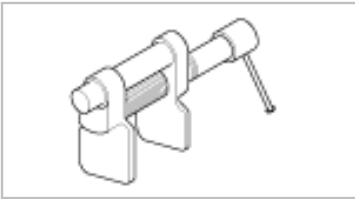
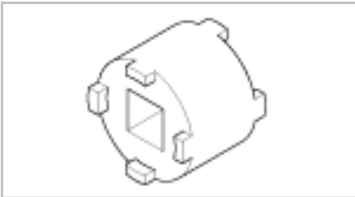

SPECIAL TOOLS

Tool (Number and Name)	Illustration	Use
06581-11000 Piston expander		Spreading the front brake piston
09580-34000 Rear brake piston adjuster		Removal and installation of the rear brake piston

SPECIAL TOOLS

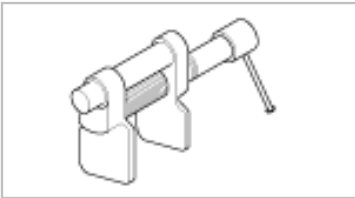
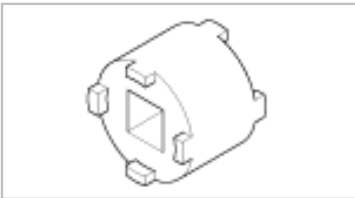
Tool (Number and Name)	Illustration	Use
06581-11000 Piston expander		Spreading the front brake piston
09580-34000 Rear brake piston adjuster		Removal and installation of the rear brake piston



SPECIFICATIONS

Item	Specification	
Master cylinder <ul style="list-style-type: none"> •Type •I.D. mm(in.) •Fluid level warning sensor 	Tandem type 23.81 (0.937) Provided	
Brake booster <ul style="list-style-type: none"> •Type •Effective dia. mm(in.) •Boosting ratio 	Vacuum Tandem type with 7+8 in. 7.5 : 1	
Proportioning valve <ul style="list-style-type: none"> •Cut-in pressure(Split point) •Decompression ratio 	4 DR 26 Kgf/cm ² 0.27 : 1	5 DR 40 Kgf/cm ² 0.32 : 1
Front brake(Disc) <ul style="list-style-type: none"> •Type •Disc O.D. •Disc thickness •Pad thickness •Cylinder I.D. 	Floating type with ventilated disc 257 mm (10.12 in.) 24 mm (0.94 in.) 11 mm (0.43 in.) 54 mm (2.13 in.)	
Rear brake(Disc) <ul style="list-style-type: none"> •Type •Disc O.D. •Disc thickness •Pad thickness •Cylinder I.D. 	Floating type with solid disc 258 mm (10.16 in.) 10 mm (0.39 in.) 9 mm (0.35 in.) 33.96 mm (1.34 in.)	
Rear brake(Drum) <ul style="list-style-type: none"> •Type •Drum I.D. •Drum thickness •Brake lining thickness •Clearance adjustment 	Leading trailing drum 203.2 mm (8 in.) 5.2 mm (0.2 in.) 5.14 mm (0.2 in.) Automatic	

- Parking brake
- Actuation
 - Type
 - Cable arrangement

Mechanical brake acting on rear wheels
 Lever
 V type

O.D = Outer Diameter

I.D = Inner Diameter

SERVICE STANDARD

	Standard value	Service limit
Brake pedal height	135 mm (5.31 in.)	
Brake pedal stroke	128 mm +5, 0 (5.04 in. +0.2, 0)	
Stop lamp switch outer case to pedal stopper clearance	0.5~1.0 mm (0.02~0.04 in.)	
Brake pedal free play	3~8 mm (0.11~0.31 in.)	
Brake pedal to floorboard clearance	61 mm (2.40 in.) or more	
Booster push rod to master cylinder piston clearance	0 (at 500 mmHg vacuum)	
Parking brake lever stroke when lever assembly is pulled with 196N (20Kg, 44lb force)	8~9 clicks: Rear Disc type 8 clicks: Rear Drum type	
Front disc brake pad thickness	11 mm (0.43 in.)	2 mm (0.079 in.)
Front disc thickness (minimum)	24 mm (0.945 in.)	22.4 mm (0.882 in.)
Front disc runout		0.1 mm (0.004 in.)
Front disc parallelism		0.015 mm (0.0006 in.)
Rear drum brake lining thickness	4.5 mm (0.177 in.)	1.0 mm (0.039 in.)
Rear drum brake drum I.D. (maximum)	203.2 mm (8 in.)	205.2 mm (8.079 in.)
Rear disc brake pad thickness	9 mm (0.354 in.)	2 mm (0.079 in.)
Rear disc brake disc thickness	10 mm (0.4 in.)	8 mm (0.315 in.)
Rear disc runout		0.1 mm (0.004 in.)
Rear disc parallelism		0.015 mm (0.0006 in.)

TIGHTENING TORQUE

	Nm	Kgf·cm	lbf·ft
--	----	--------	--------

Master cylinder to booster mounting nut	Ebay User ID: revercus4	8~12	80~120	5.9~8.9
Brake booster mounting nut		13~16	130~160	9.6~11.8
Brake booster vacuum hose fitting to surge tank		15~18	150~180	11.1~13.3
Bleeder screw		7~13	70~130	5.2~9.6
Brake tube nut, brake hose		13~17	130~170	9.6~12.5
Caliper guide rod bolt		22~32	220~320	16.2~23.6
Caliper pin bolt		35~45	350~450	25.8~33.2
Caliper assembly to knuckle		69~85	690~850	50.9~62.7
Brake hose to front caliper		25~30	250~300	18.4~22.1
Brake hub flange nut		200~260	2000~2600	147.5~191.8
Wheel cylinder mounting bolt		5~11	50~110	3.7~8.1

CAUTION

Replace self-locking nuts with new ones after removal.

SPECIFICATIONS

Item	Specification	
Master cylinder <ul style="list-style-type: none"> •Type •I.D. mm(in.) •Fluid level warning sensor 	Tandem type 23.81 (0.937) Provided	
Brake booster <ul style="list-style-type: none"> •Type •Effective dia. mm(in.) •Boosting ratio 	Vacuum Tandem type with 7+8 in. 7.5 : 1	
Proportioning valve <ul style="list-style-type: none"> •Cut-in pressure(Split point) •Decompression ratio 	4 DR 26 Kgf/cm ² 0.27 : 1	5 DR 40 Kgf/cm ² 0.32 : 1
Front brake(Disc) <ul style="list-style-type: none"> •Type •Disc O.D. •Disc thickness •Pad thickness •Cylinder I.D. 	Floating type with ventilated disc 257 mm (10.12 in.) 24 mm (0.94 in.) 11 mm (0.43 in.) 54 mm (2.13 in.)	

Rear brake(Disc) •Type •Disc O.D. •Disc thickness •Pad thickness •Cylinder I.D.	Floating type with solid disc 258 mm (10.16 in.) 10 mm (0.39 in.) 9 mm (0.35 in.) 33.96 mm (1.34 in.)
Rear brake(Drum) •Type •Drum I.D. •Drum thickness •Brake lining thickness •Clearance adjustment	Leading trailing drum 203.2 mm (8 in.) 5.2 mm (0.2 in.) 5.14 mm (0.2 in.) Automatic
Parking brake •Actuation •Type •Cable arrangement	Mechanical brake acting on rear wheels Lever V type

O.D = Outer Diameter

I.D = Inner Diameter

SERVICE STANDARD

	Standard value	Service limit
Brake pedal height	135 mm (5.31 in.)	
Brake pedal stroke	128 mm +5, 0 (5.04 in. +0.2, 0)	
Stop lamp switch outer case to pedal stopper clearance	0.5~1.0 mm (0.02~0.04 in.)	
Brake pedal free play	3~8 mm (0.11~0.31 in.)	
Brake pedal to floorboard clearance	61 mm (2.40 in.) or more	
Booster push rod to master cylinder piston clearance	0 (at 500 mmHg vacuum)	
Parking brake lever stroke when lever assembly is pulled with 196N (20Kg, 44lb force)	8~9 clicks: Rear Disc type 8 clicks: Rear Drum type	
Front disc brake pad thickness	11 mm (0.43 in.)	2 mm (0.079 in.)
Front disc thickness (minimum)	24 mm (0.945 in.)	22.4 mm (0.882 in.)
Front disc runout		0.1 mm (0.004 in.)

Front disc parallelism	Ebay User ID: reveleus1	0.015 mm (0.0006 in.)
Rear drum brake lining thickness	4.5 mm (0.177 in.)	1.0 mm (0.039 in.)
Rear drum brake drum I.D. (maximum)	203.2 mm (8 in.)	205.2 mm (8.079 in.)
Rear disc brake pad thickness	9 mm (0.354 in.)	2 mm (0.079 in.)
Rear disc brake disc thickness	10 mm (0.4 in.)	8 mm (0.315 in.)
Rear disc runout		0.1 mm (0.004 in.)
Rear disc parallelism		0.015 mm (0.0006 in.)

TIGHTENING TORQUE

	Nm	Kgf-cm	lbf-ft
Master cylinder to booster mounting nut	8~12	80~120	5.9~8.9
Brake booster mounting nut	13~16	130~160	9.6~11.8
Brake booster vacuum hose fitting to surge tank	15~18	150~180	11.1~13.3
Bleeder screw	7~13	70~130	5.2~9.6
Brake tube nut, brake hose	13~17	130~170	9.6~12.5
Caliper guide rod bolt	22~32	220~320	16.2~23.6
Caliper pin bolt	35~45	350~450	25.8~33.2
Caliper assembly to knuckle	69~85	690~850	50.9~62.7
Brake hose to front caliper	25~30	250~300	18.4~22.1
Brake hub flange nut	200~260	2000~2600	147.5~191.8
Wheel cylinder mounting bolt	5~11	50~110	3.7~8.1

CAUTION

Replace self-locking nuts with new ones after removal.



TROUBLESHOOTING

PROBLEM SYMPTOMS TABLE

Symptom	Suspect Area	See page
Lower pedal or spongy pedal	<ol style="list-style-type: none"> 1. Brake system (Fluid leaks) 2. Brake system (Air in) 3. Piston seals (Worn or damaged) 4. Master cylinder (Faulty) 	BR-17 BR-12 BR-26, 32 BR-19
Brake drag	<ol style="list-style-type: none"> 1. Brake pedal freeplay (Minimal) 2. Parking brake lever travel (Out of adjustment) 3. Parking brake wire (Sticking) 4. Pad or lining (Cracked or distorted) 5. Piston (Stuck) 6. Piston (Frozen) 7. Return spring (Faulty) 8. Booster system (Vacuum leaks) 9. Master cylinder (Faulty) 	BR-10 BR-11 BR-42 BR-27,33,39 BR-26,32 BR-26,32 BR-37 BR-24 BR-19
Brake pull	<ol style="list-style-type: none"> 1. Pad or lining (Oily) 2. Piston (Frozen) 3. Disc (Scored) 4. Pad or lining (Cracked or distorted) 	BR-27,33,39 BR-26,32 BR-25,31 BR-27,33,39
Hard pedal but brake inefficient	<ol style="list-style-type: none"> 1. Brake system (Fluid leaks) 2. Brake system (Air in) 3. Pad or lining (Worn) 4. Pad or lining (Cracked or distorted) 5. Pad or lining (Oily) 6. Pad or lining (Glazed) 7. Disc (Scored) 8. Booster system (Vacuum leaks) 	BR-17 BR-12 BR-27,33,39 BR-27,33,39 BR-27,33,39 BR-27,33,39 BR-25,31 BR-24

Noise from brake	<ol style="list-style-type: none"> 1. Pad or lining (Cracked or distorted) 2. Installation bolt (Loosen) 3. Disc (Scored) 4. Pad retainers (Loosen) 5. Sliding pin (Worn) 6. Pad or lining (Dirty) 7. Pad or lining (Glazed) 8. Return spring (Faulty) 9. Brake pad shim (Damage) 10. Shoe hold-down spring (Damage) 	BR-27,33,39 BR-25,31 BR-25,31 BR-25,31 BR-25,31 BR-27,33,39 BR-27,33,39 BR-37 BR-25,31 BR-37
------------------	--	---

TROUBLESHOOTING

PROBLEM SYMPTOMS TABLE

Symptom	Suspect Area	See page
Lower pedal or spongy pedal	<ol style="list-style-type: none"> 1. Brake system (Fluid leaks) 2. Brake system (Air in) 3. Piston seals (Worn or damaged) 4. Master cylinder (Faulty) 	BR-17 BR-12 BR-26, 32 BR-19
Brake drag	<ol style="list-style-type: none"> 1. Brake pedal freeplay (Minimal) 2. Parking brake lever travel (Out of adjustment) 3. Parking brake wire (Sticking) 4. Pad or lining (Cracked or distorted) 5. Piston (Stuck) 6. Piston (Frozen) 7. Return spring (Faulty) 8. Booster system (Vacuum leaks) 9. Master cylinder (Faulty) 	BR-10 BR-11 BR-42 BR-27,33,39 BR-26,32 BR-26,32 BR-37 BR-24 BR-19
Brake pull	<ol style="list-style-type: none"> 1. Pad or lining (Oily) 2. Piston (Frozen) 3. Disc (Scored) 4. Pad or lining (Cracked or distorted) 	BR-27,33,39 BR-26,32 BR-25,31 BR-27,33,39

Hard pedal but brake inefficient	<ol style="list-style-type: none"> 1. Brake system (Fluid leaks) 2. Brake system (Air in) 3. Pad or lining (Worn) 4. Pad or lining (Cracked or distorted) 5. Pad or lining (Oily) 6. Pad or lining (Glazed) 7. Disc (Scored) 8. Booster system (Vacuum leaks) 	<p style="text-align: center;">BR-17 BR-12 BR-27,33,39 BR-27,33,39 BR-27,33,39 BR-27,33,39 BR-25,31 BR-24</p>
Noise from brake	<ol style="list-style-type: none"> 1. Pad or lining (Cracked or distorted) 2. Installation bolt (Loosen) 3. Disc (Scored) 4. Pad retainers (Loosen) 5. Sliding pin (Worn) 6. Pad or lining (Dirty) 7. Pad or lining (Glazed) 8. Return spring (Faulty) 9. Brake pad shim (Damage) 10. Shoe hold-down spring (Damage) 	<p style="text-align: center;">BR-27,33,39 BR-25,31 BR-25,31 BR-25,31 BR-25,31 BR-27,33,39 BR-27,33,39 BR-37 BR-25,31 BR-37</p>