



HYUNDAI

Elantra



Workshop Manual
2001 - 2006

COMPONENTS

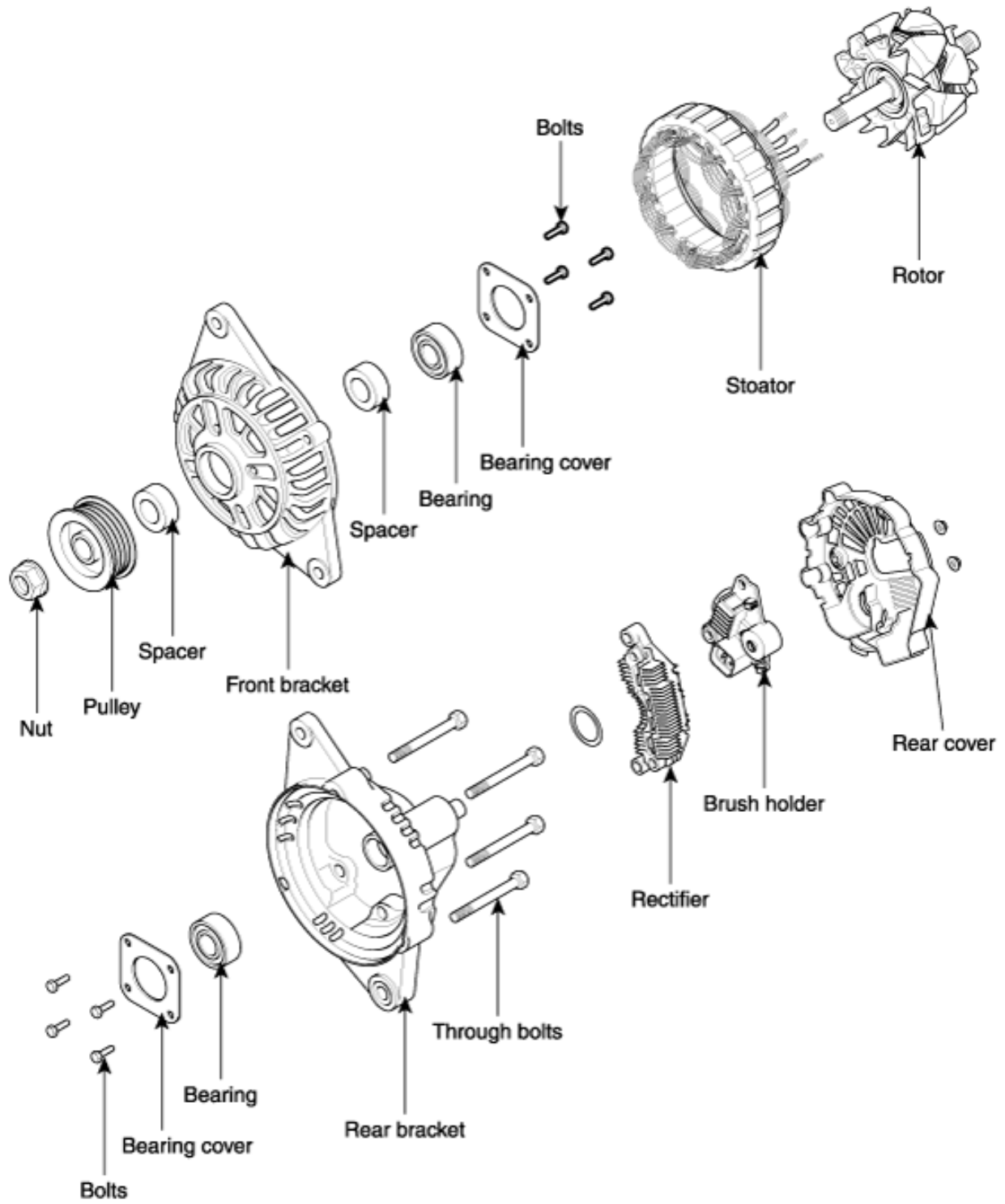

REPLACEMENT

1. Disconnect the battery negative terminal first, then the positive terminal.
2. Disconnect the generator connector(A) and "B" terminal cable(B) from the generator(C).

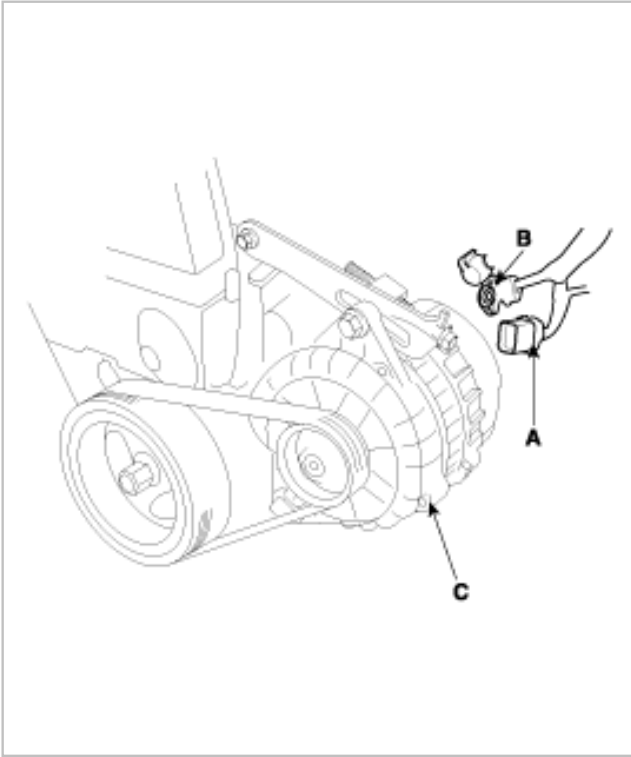

3. Remove the adjusting bolt(A) and mounting bolt(B), then remove the generator belt(C).
4. Pull out the through bolt(C), then remove the generator(D).

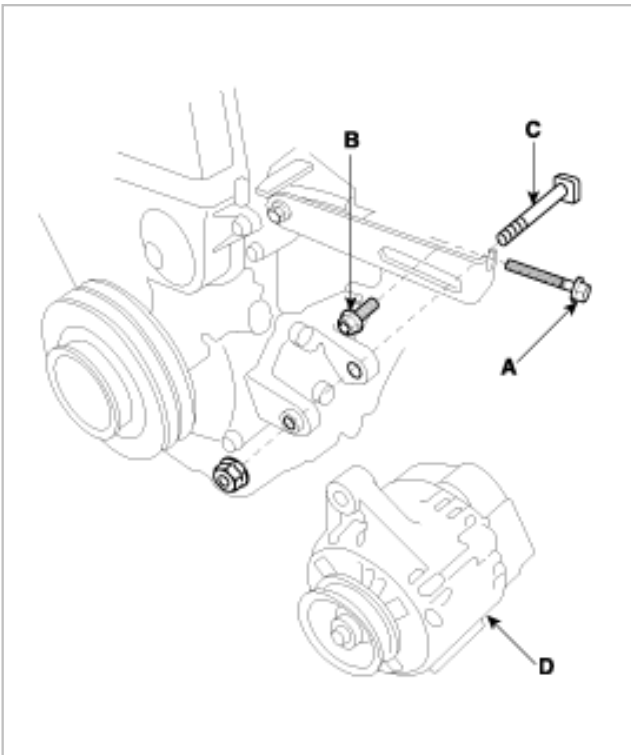

5. Installation is the reverse of removal.

6. Adjust the generator belt tension after installation (See page EE-33).
Ebay User ID: reveleus1

ALTERNATOR BELT INSPECTION AND ADJUSTMENT

NOTE

When using a new belt, first adjust the deflection or tension to the values for the new belt, then readjust the deflection or tension to the values for the used belt after running engine for five minutes.

Deflection method :

Apply a force of 98N (10 kgf, 22 lbf), and measure the deflection between the alternator and crankshaft pulley.

Deflection

Used Belt : 8.5 ~ 11.5 mm (0.33 ~ 0.345 in)

New Belt : 5.5 ~ 8.0 mm (0.22 ~ 0.361 in)

NOTE

If the belt is worn or damaged, replace it.

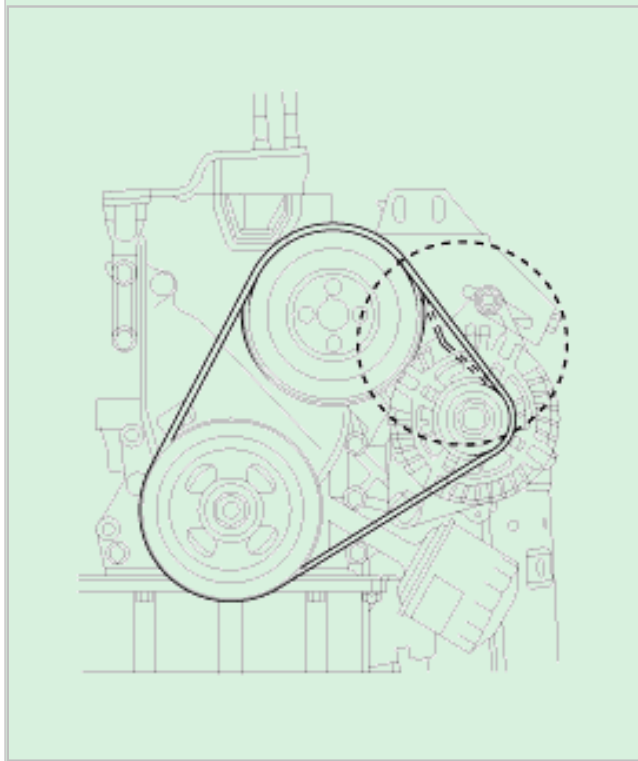

Belt tension gauge method :

Attach the belt tension gauge to the belt and measure the tension. Follow the gauge manufacturer's instructions.

Tension

Used Belt : 340~490 N (35~50 kgf, 77~110 lbf)

New Belt : 690~880 N (70~90 kgf, 150~200 lbf)

If the belt is worn or damaged, replace it.

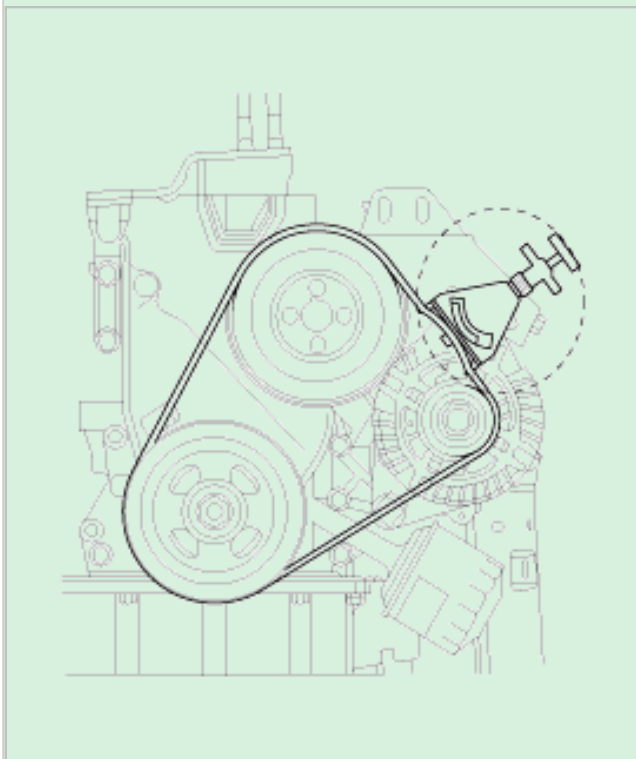

If adjustment is necessary :

1. Loosen the adjusting bolt(A) and the lock bolt(B).
2. Move the alternator to obtain the proper belt tension, then retighten the nuts.

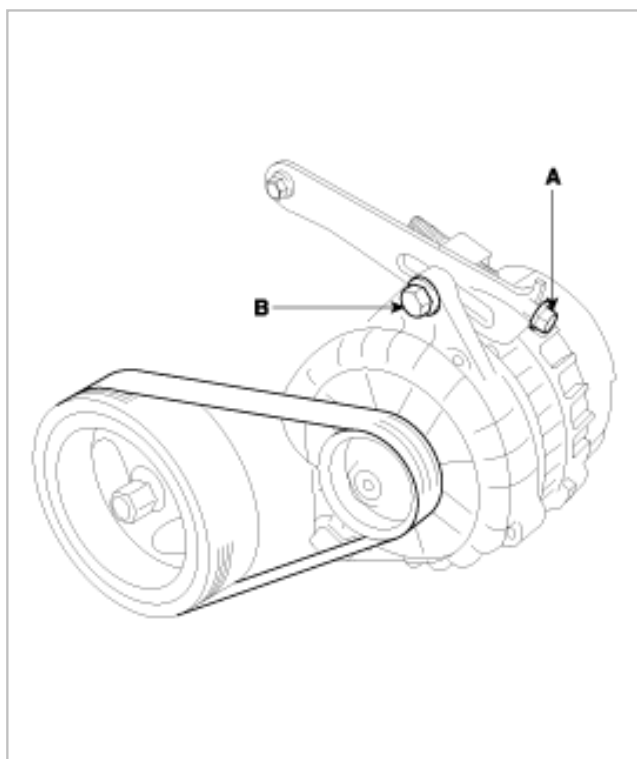

3. Recheck the deflection or tension of the belt. Ebay User ID: reveleus1

NOTE

For the power steering pump belt and A/C compressor belt adjustments, refer to section 17 and section 22.



DESCRIPTION

1. The maintenance-free battery is, as the name implies, totally maintenance free and has no removable battery cell caps.
2. Water never needs to be added to the maintenance-free battery.
3. The battery is completely sealed, except for small vent holes in the cover.

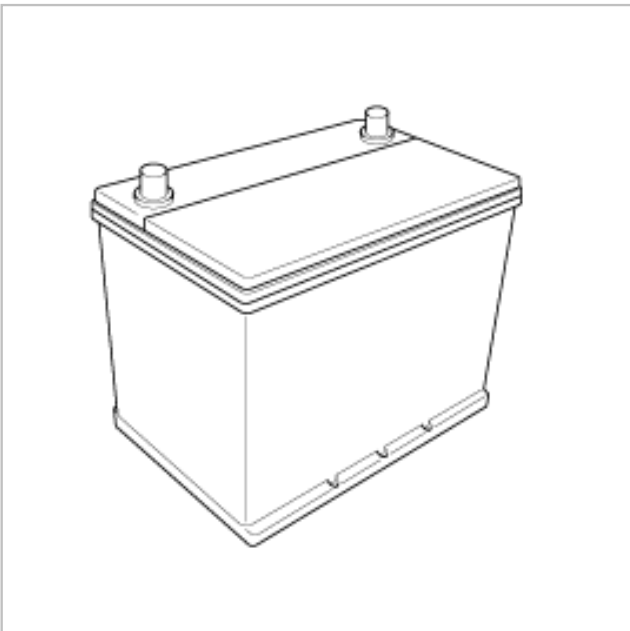



INSPECTION

BATTERY DIAGNOSTIC TEST (1)

1. CHECKING FLOW

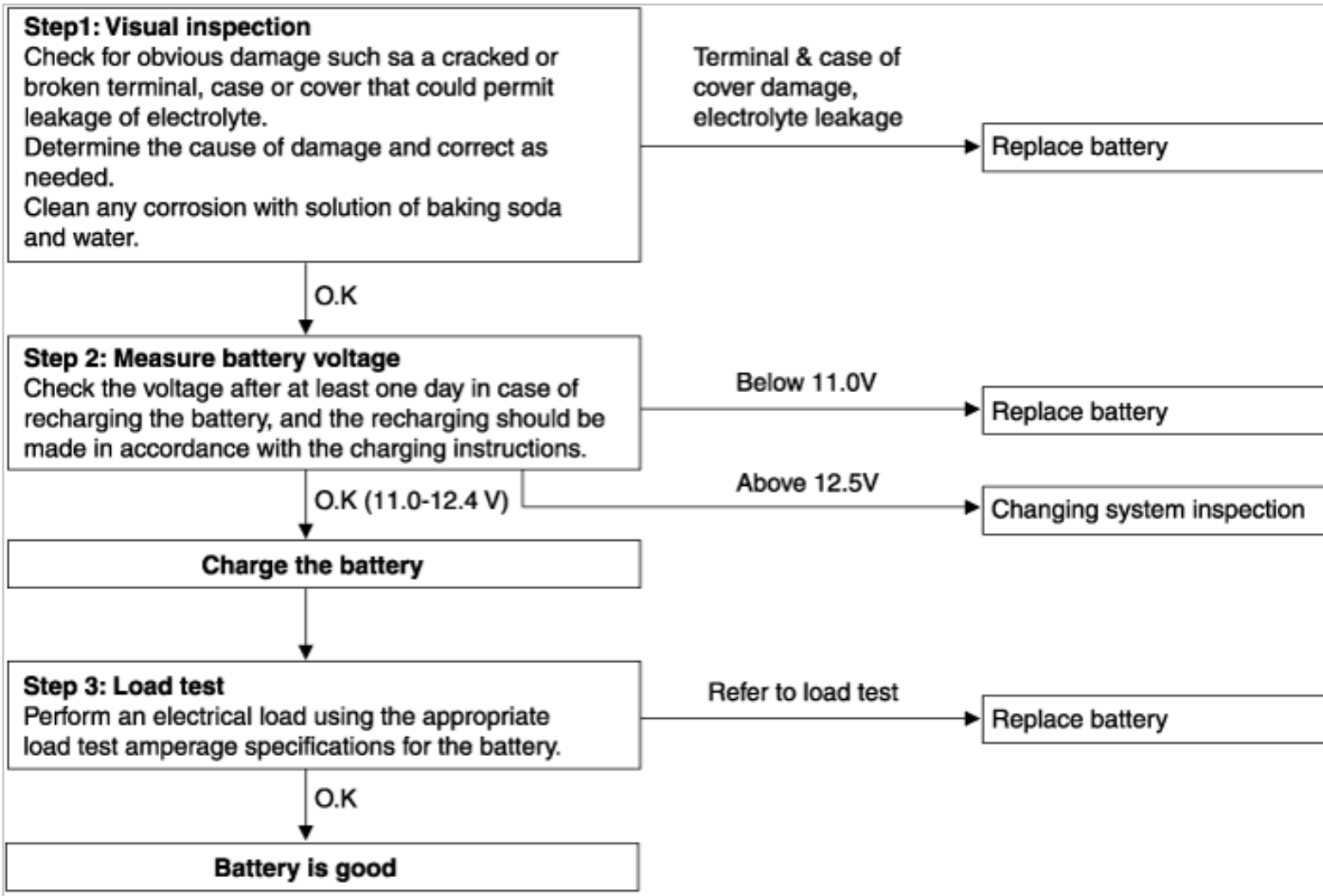

2. CHECKING SHEET

Inspection Items & contents	Judgment criteria	Responsibility		Remarks
		User	Manufacturer	
1. Acid Leakage * Type of acid leakage -Leakage on the fusion part for joining the case and cover. -Leakage on the terminal part -Leakage on other parts * Conduct a visual inspection for breakage, deformation, or cracks.	1. Damage in the case or cover due to outside impact.			
	2. Acid leakage on the molding part of the case or cover. (weld line or gate hole)			
	3. Damage on the terminal or cracks in the cover.			
	4. Acid leakage due to the tipped battery or slant storage.			

	5. Acid leakage due to poor welding of the cover. (with no damage)		
2. Outside damage and breakage	1. Outside damage due to causes without damage due to mistreatment.		
	2. Outside damage due to mistreatment.		
	3. Damage due to a spark between terminals.		
	4. Damage and breakage due to heat.		
3. Measure the voltage for the battery ; Wait at least one day before measuring in case of recharging.	1. 12.0V		Refer to load test
	2. 11.0V < battery voltage < 12.0V due to over-discharge.		Refer to load test
	3. Below 11.0V due to charge condition failure.		Refer to load test
	4. Below 11.0V due to discharged for a long period.		Refer to load test
	5. Below 11.0V due to internal short circuit.		Refer to load test
4. Load test ; For 15 seconds with half of the CCA value. The voltage on the discharging stage should be above 9.6V (81±9°F) -Conduct the test with a battery tester. (Refer to the tester manual)	1. Load test result: below 9.5V		
	2. Load test result: above 9.6V		

3. LOAD TEST

1. Perform the following steps to complete the load test procedure for maintenance free batteries.

2. Connect the load tester clamps to the terminals and proceed with the test as follow :

- A. If the battery has been on charge, remove the surface charge by connecting a 300 ampere load for 15 seconds.
- B. Connect the voltmeter and apply the specified load.
- C. Read the voltage after the load has been applied for 15 seconds.
- D. Disconnect the load.
- E. Compare the voltage reading with the minimum and replace the battery if battery test voltage is below that shown in the voltage table.

Voltage	Temperature
9.6	20°C (70°F) and above
9.5	16 °C (60 °F)
9.4	10 °C (50 °F)
9.3	4 °C (40 °F)
9.1	-1 °C (30 °F)
8.9	-7 °C (20 °F)
8.7	-12 °C (10 °F)
8.5	-18 °C (0 °F)

NOTE

- If the voltage is higher than shown in the table, the battery is good.
- If the voltage is lower than shown in the table, replace the battery.

BATTERY DIAGNOSTIC TEST (2)

1. Make sure the ignition switch and all accessories are in the OFF position.
2. Disconnect the battery cables (negative first).
3. Remove the battery from the vehicle.

CAUTION

Care should be taken in the event the battery case is cracked or leaking, to protect your skin from the electrolyte. Heavy rubber gloves (not the household type) should be worn when removing the battery.

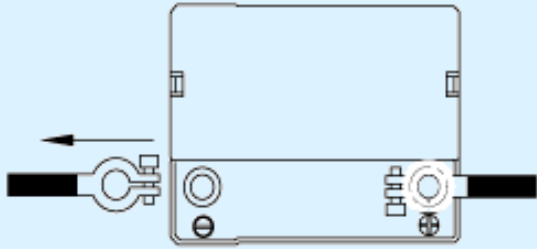

4. Inspect the battery carrier for damage caused by the loss of electrolyte. If acid damage is present, it will be necessary to clean the area with a solution of clean warm water and baking soda. Scrub the area with a stiff brush and wipe off with a cloth moistened with baking soda and water.
5. Clean the top of the battery with the same solution as described in Step(4).
6. Inspect the battery case and cover for cracks. If cracks are present, the battery must be replaced.
7. Clean the battery posts with a suitable battery post cleaning tool.
8. Clean the inside surface of the terminal clamps with a suitable battery cleaning tool. Replace damaged cables and broken terminal clamps.
9. Install the battery in the vehicle.
10. Connect the cable terminals to the battery post, making sure the tops of the terminals are flush with the tops of the posts.
11. Tighten the terminal nuts securely.
12. Coat all connections with light mineral grease after tightening.

CAUTION

When batteries are being charged, an explosive gas forms beneath the cover of each cell. Do not smoke near batteries being charged or which have recently been charged. Do not break live circuits at the terminals of batteries being charged. A spark will occur when the circuit is broken. Keep open flames away from the battery.

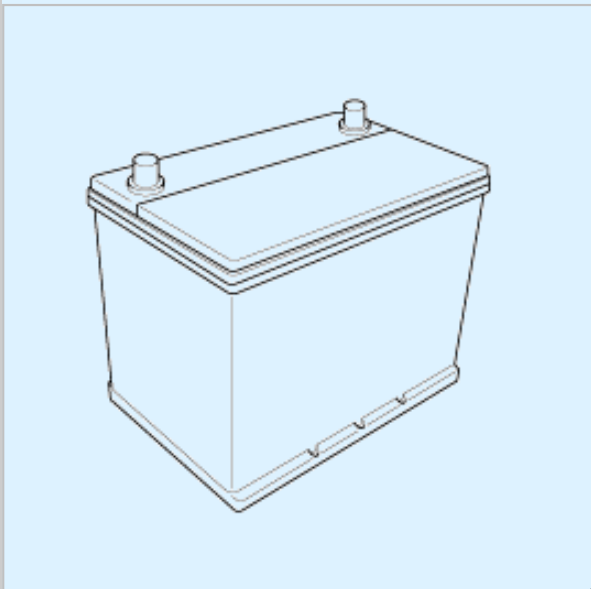

DESCRIPTION

The charging system includes a battery, generator with a built-in regulator, The charging indicator light and wiring. The generator has eight built-in diodes (four positive and four negative), each rectifying AC current to DC current. Therefore, DC current appears at generator "B" terminal.

In addition, the charging voltage of this generator is regulated by the battery voltage detection system.

The generator is regulated by the battery voltage detection system. The main components of the generator are the rotor, stator, rectifier, capacitor brushes, bearings and V-ribbed belt pulley. The brush holder contains a built-in electronic voltage regulator.

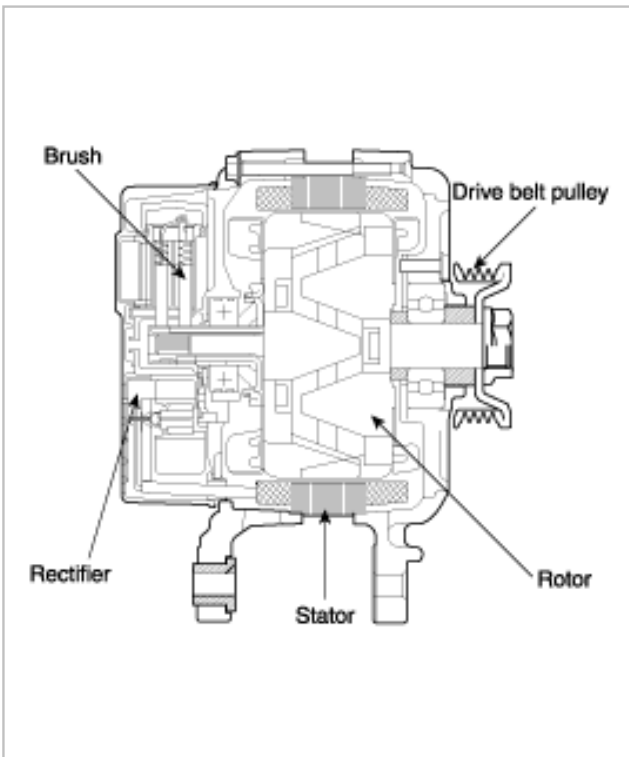



ON-VEHICLE INSPECTION

CAUTION

- Check that the battery cables are connected to the correct terminals.
- Disconnect the battery cables when the battery is given a quick charge.
- Do not perform tests with a high voltage insulation resistance tester.
- Never disconnect the battery while the engine is running.

CHECK BATTERY VOLTAGE

1. If 20 minutes have not passed since the engine was stopped, turn the ignition switch ON and turn on the electrical system (headlamp, blower motor, rear defogger etc.) for 60 seconds to remove the surface charge.
2. Turn the ignition switch OFF and turn off the electrical systems.
3. Measure the battery voltage between the negative (-) and positive (+) terminals of the battery.

Standard voltage : 12.5~12.9V at 20°C (68°C)

If the voltage is less than specification, charge the battery.

CHECK BATTERY TERMINALS, FUSIBLE LINK AND FUSES

1. Check that the battery terminals are not loose or corroded.
2. Check the fusible link and fuses for continuity.

INSPECT DRIVE BELT

1. Visually check the belt for excessive wear, frayed cords etc.

If any defect has been found, replace the drive belt.

NOTE

Cracks on the rib side of a belt are considered acceptable. If the belt has chunks missing from the ribs, it should be replaced.

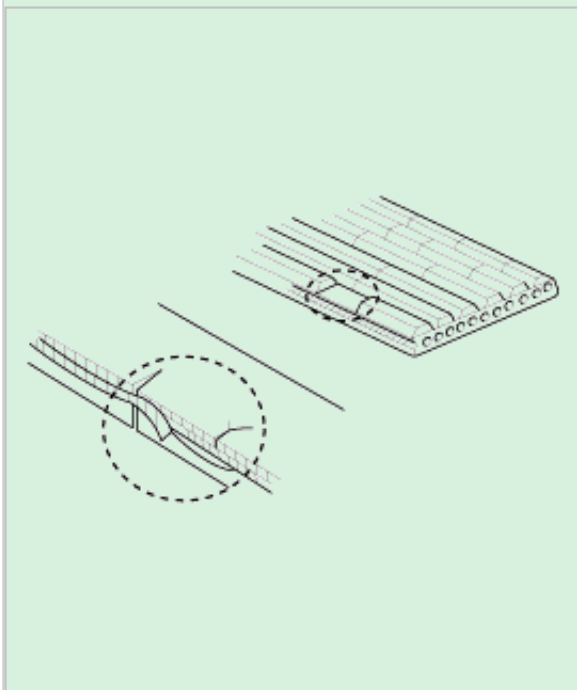

2. Using a belt tension gauge, measure the drive belt tension.
Ebay User ID: reveleus1

DRIVE BELT TENSION

New belt	690~880 N (150~200 lb)
Used belt	340~490 N (77~110 lb)

If the belt tension is not as specified, adjust it.

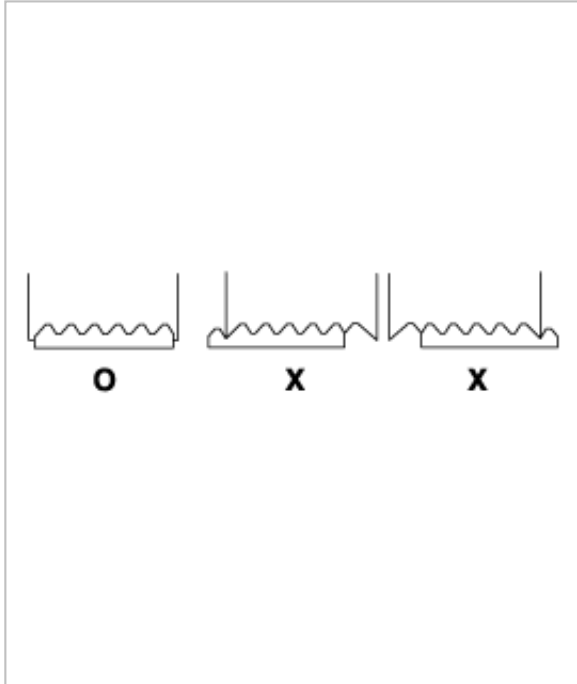
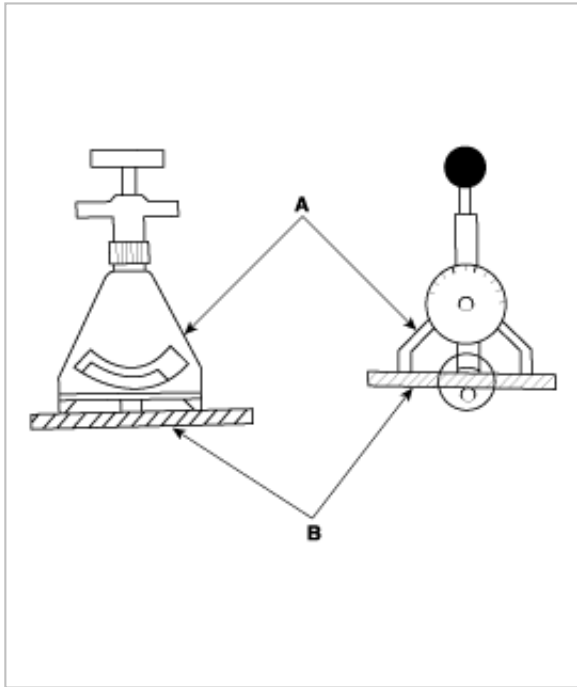

NOTE

Ebay User ID: reveleus1

- "New belt" refers to a belt which has been used less than 5 minutes on a running engine.
- "Used belt" refers to a belt which has been used on a running engine for 5 minutes or more.
- After installing a belt, check that it fits properly in the ribbed grooves.
- Check with your hand to confirm that the belt has not slipped out of the groove on the bottom of the pulley.
- After installing a new belt, run the engine for about 5 minutes and recheck the belt tension.

VISUALLY CHECK GENERATOR WIRING AND LISTEN FOR ABNORMAL NOISES

1. Check that the wiring is in good condition.
2. Check that there is no abnormal noise from the generator while the engine is running.

CHECK DISCHARGE WARNING LIGHT CIRCUIT

1. Warm up the engine and then turn it off.
2. Turn off all accessories.
3. Turn the ignition switch "ON". Check that the discharge warning light is lit.
4. Start the engine. Check that the light goes off.

INSPECT CHARGING SYSTEM

PREPARATION

1. Turn the ignition switch to "OFF".

NOTE

To find abnormal conditions of the connection, actions should not be taken on the two terminals and each connection during the test.

2. Connect a digital voltmeter between the generator "B" terminal and battery (+) lead wire to the battery (+) terminal. Connect the (+) lead wire of the voltmeter to the "B" terminal and the (-) lead wire to the battery (+) terminal.

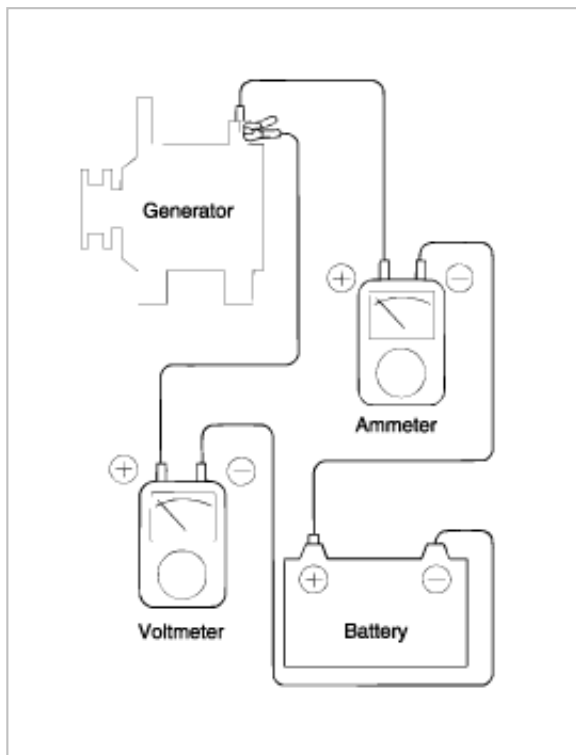

CONDITIONS FOR THE TEST

1. Start the engine.

2. Switch on the headlamps, blower motor and so on. And then, read the voltmeter under this condition.

Ebay User ID: reveleus1

RESULT

1. The voltmeter may indicate the standard value.

0.2V max.

2. If the value of the voltmeter is higher than expected (above 0.2V max.), poor wiring is suspected. In this case check the wiring from the generator "B" terminal to the fusible link to the battery (+) terminal. Check for loose connections, color change due to an overheated harness, etc. Correct them before testing again.

3. Upon completion of the test, set the engine speed at idle. Turn off the head lamps, blower motor and the ignition switch.

PREPARATION

1. Prior to the test, check the following items and correct as necessary.

Check the battery installed in the vehicle to ensure that it is in good condition. The battery checking method is described in "BATTERY".

The battery that is used to test the output current should be one that has been partially discharged. With a fully charged battery, the test may not be conducted correctly due to an insufficient load.

Check the tension of the generator drive belt. The belt tension check method is described in the section "COOLING".

2. Turn off the ignition switch.

3. Disconnect the battery ground cable.

4. Disconnect the generator output wire from the generator "B" terminal.

5. Connect a DC ammeter (0 to 150A) in series between the "B" terminal and the disconnected output wire. Be sure to connect the (-) lead wire of the ammeter to the disconnected output wire.

NOTE

Tighten each connection securely, as a heavy current will flow. Do not rely on clips.

6. Connect a voltmeter (0 to 20V) between the "B" terminal and ground. Connect the (+) lead wire to the generator "B" terminal and (-) lead wire to a good ground.

7. Attach an engine tachometer and connect the battery ground cable.

8. Leave the engine hood open.

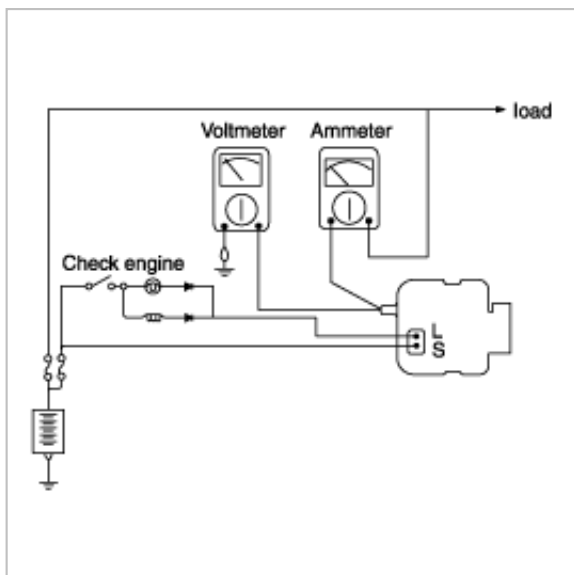

TEST

1. Check to see that the voltmeter reads as the same value as the battery voltage. If the voltmeter reads 0V, and the open circuit in the wire between the generator "B" terminal and battery (-) terminal, a blown fusible link or poor grounding is suspected.
2. Start the engine and turn on the headlights.
3. Set the headlights to high beam and the heater blower switch to HIGH, quickly increase the engine speed to 2,500 rpm and read the maximum output current value indicated by the ammeter.

NOTE

After the engine starts up, the charging current quickly drops. Therefore, the above operation must be done quickly to read the maximum current value correctly.

RESULT

1. The ammeter reading must be higher than the limit value. If it is lower but the generator output wire is in good condition, remove the generator from the vehicle and test it.

63A min.

NOTE

- The nominal output current value is shown on the nameplate affixed to the generator body.
- The output current value changes with the electrical load and the temperature of the generator itself. Therefore, the nominal output current may not be obtained. If such is the case, keep the headlights on to cause discharge of the battery.

The nominal output current may not be obtained if the temperature of the generator itself or ambient temperature is too high.

In such a case, reduce the temperature before testing again.

2. Upon completion of the output current test, lower the engine speed to idle and turn off the ignition switch.
3. Disconnect the battery ground cable.
4. Remove the ammeter and voltmeter and the engine tachometer.
5. Connect the generator output wire to the generator "B" terminal.
6. Connect the battery ground cable.

PREPARATION

1. Prior to the test, check the following items and correct if necessary.
- Check that the battery installed in the vehicle is fully charged. For battery checking method, see "BATTERY".
- Check the generator drive belt tension. For belt tension check, see "COOLING" section.
2. Turn ignition switch to "OFF".
3. Disconnect the battery ground cable.
4. Connect a digital voltmeter between the "B" terminal of the generator and ground. Connect the (+) lead of the voltmeter to the "B" terminal of the generator. Connect the (-) lead to good ground or the battery (-) terminal.
5. Disconnect the generator output wire from the generator "B" terminal.
6. Connect a DC ammeter (0 to 150A) in series between the "B" terminal and the disconnected output wire. Connect the (-) lead wire of the ammeter to the disconnected output wire.

7. Attach the engine tachometer and connect the battery ground cable.
Ebay User ID: reveleus1

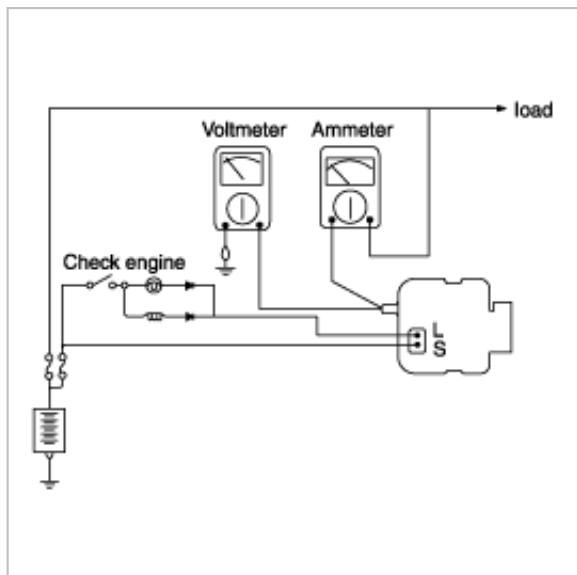

TEST

1. Turn on the ignition switch and check to see that the voltmeter indicates the following value.

Battery voltage

If it reads 0V, there is an open circuit in the wire between the generator "B" terminal and the battery (-), or the fusible link is blown.

2. Start the engine. Keep all lights and accessories off.

3. Run the engine at a speed of about 2,500 rpm and read the voltmeter when the generator output current drops to 10A or less.

RESULT

1. If the voltmeter reading agrees with the value listed in the Regulating Voltage Table below, the voltage regulator is functioning correctly. If the reading is other than the standard value, the voltage regulator or the generator is faulty.

Regulating Voltage Table

Voltage regulator ambient temperature °C (°F)	Regulating voltage (V)
-20 (-4)	14.2 ~ 15.4
20 (68)	14.0 ~ 15.0
60 (140)	13.7 ~ 14.9
80 (176)	13.5 ~ 14.7

2. Upon completion of the test, reduce the engine speed to idle, and turn off the ignition switch.

3. Disconnect the battery ground cable.

4. Remove the voltmeter and ammeter and the engine tachometer.

5. Connect the generator output wire to the generator "B" terminal.

6. Connect the battery ground cable.

1. Be sure to check the following before testing:

Generator installation and wiring connections

Generator drive belt tension

Fusible link

Abnormal noise from the generator while the engine is running

2. Turn the ignition switch to the OFF position.

3. Disconnect the negative battery cable.

Ebay User ID: reveleus1

4. Disconnect the generator output wire from the generator "B" terminal. Connect a DC test ammeter with a range of 0-150A in series between the "B" terminal and the disconnected output wire. (Connect the (+) lead of the ammeter to the "B" terminal. Connect the (-) lead of the ammeter to the disconnected output wire).

NOTE

An inductive-type ammeter which enables measurements to be taken without disconnecting the generator output wire is recommended. Using this equipment will lessen the possibility of a voltage drop caused by a loose "B" terminal connection.

5. Connect a digital-type voltmeter between the generator "B" terminal and the battery (+) terminal. (Connect the (+) lead of the voltmeter to the "B" terminal. Connect the (-) lead of the voltmeter to the battery (+) cable.)

6. Reconnect the negative battery cable.

7. Connect a tachometer or the scan tool.

8. Start the engine.

9. With the engine running at approx. 2500 r/min, turn the headlights and other lights on and off to adjust the generator load on the ammeter slightly above 30A.

max. 0.3V

NOTE

When the generator output is high and the value displayed on the ammeter does not decrease to 30A, set the value to 40A. Read the value displayed on the voltmeter. In this case the limit becomes max. 0.4V.

10. If the value displayed on the voltmeter is still above the limit, a malfunction in the generator output wire may exist. Check the wiring between the generator "B" terminal and the battery (+) terminal (including fusible link). If a terminal is not sufficiently tight or if the harness has become discolored due to overheating, repair, the test again.

11. After the test, run the engine at idle.

12. Turn off all lights and turn the ignition switch to the OFF position.

13. Disconnect the tachometer or the scan tool.

14. Disconnect the negative battery cable.

15. Disconnect the ammeter and voltmeter.

16. Connect the generator output wire to the generator "B" terminal.

17. Connect the negative battery cable.

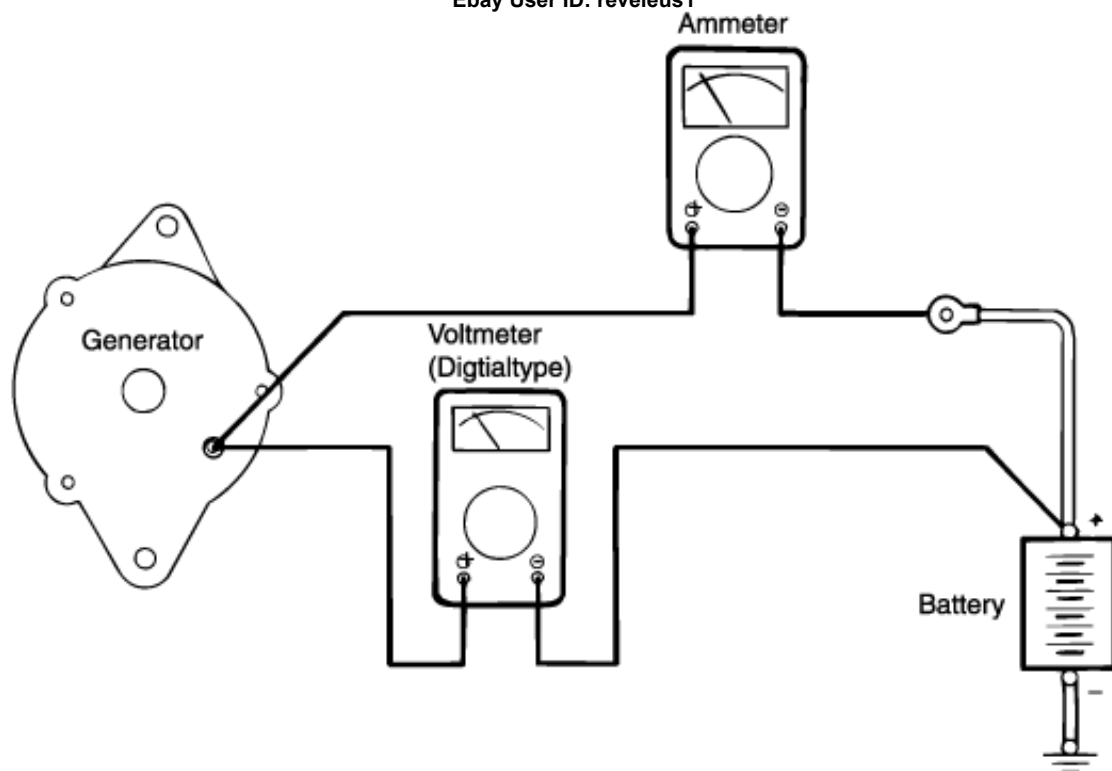

CIRCUIT DIAGRAM FOR CHARGING SYSTEM

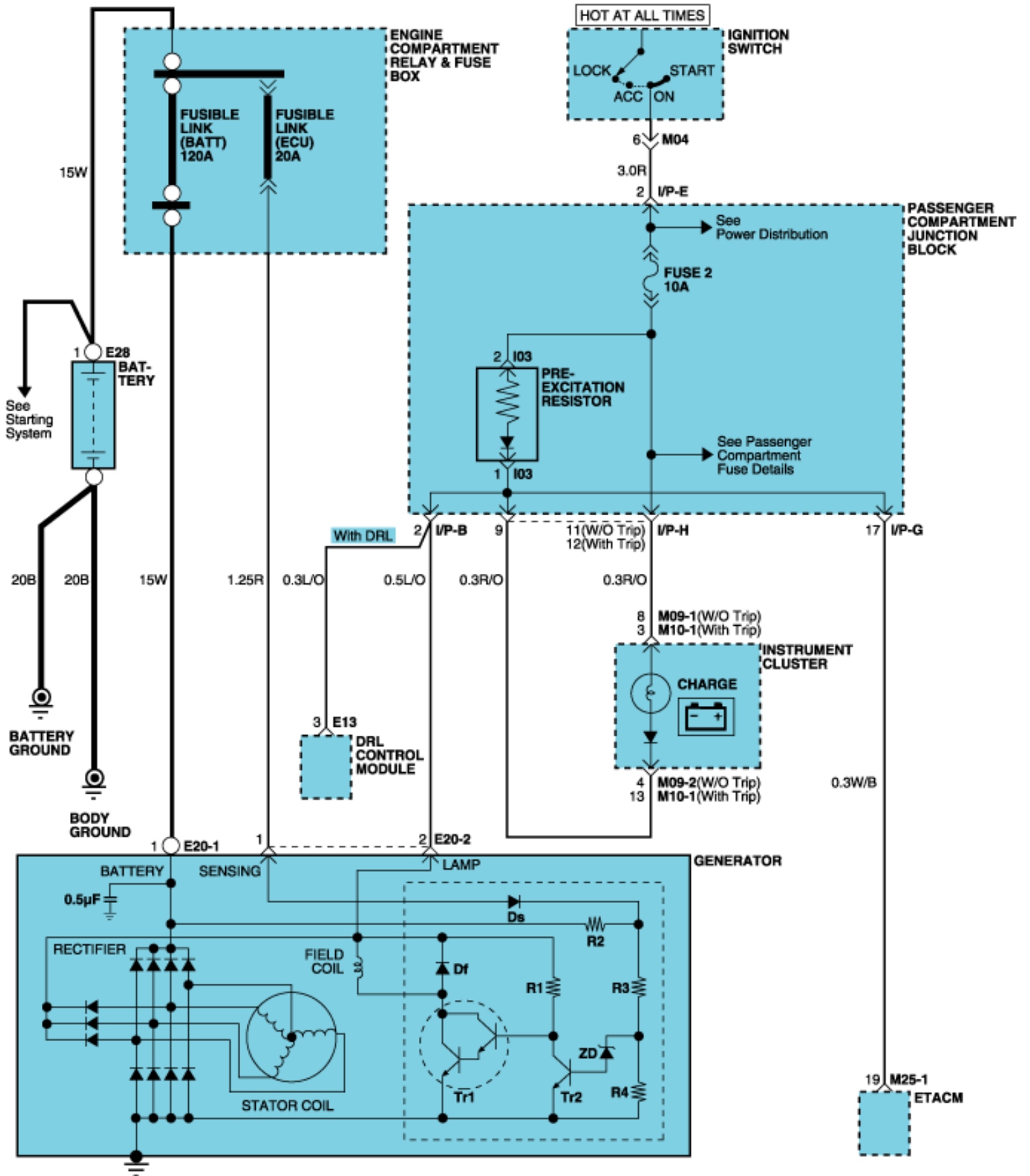

COMPONENTS LOCATION

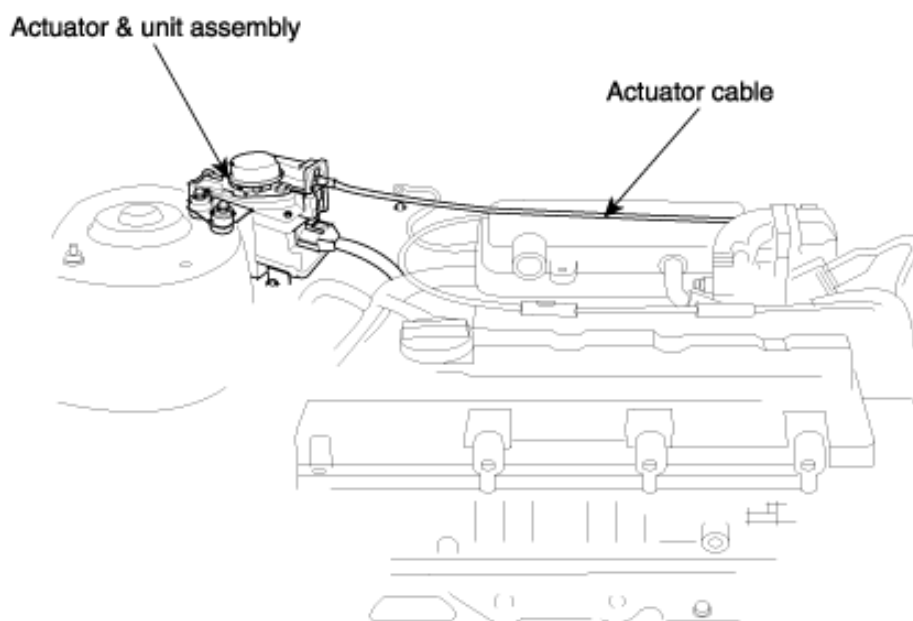
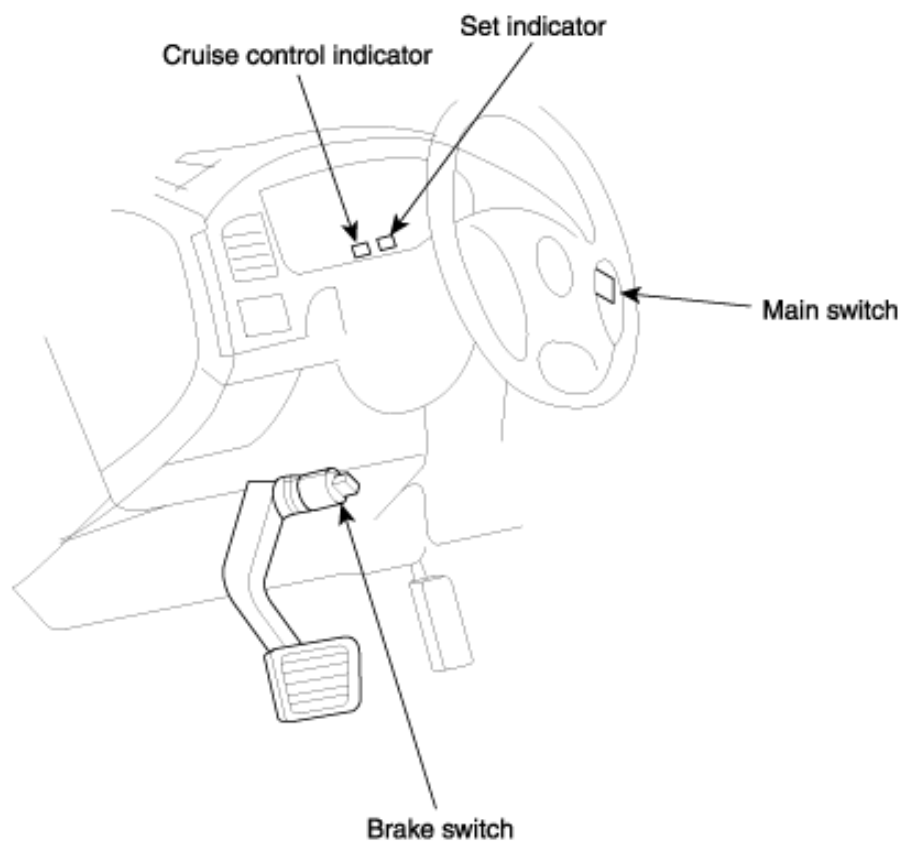

INSPECTION

CRUISE CONTROL SWITCH TEST

1. Disconnect the battery negative cable, then disconnect the positive cable, and wait at least three minutes.
2. Remove the driver's airbag (See page RT).
3. Disconnect the control switch connector.

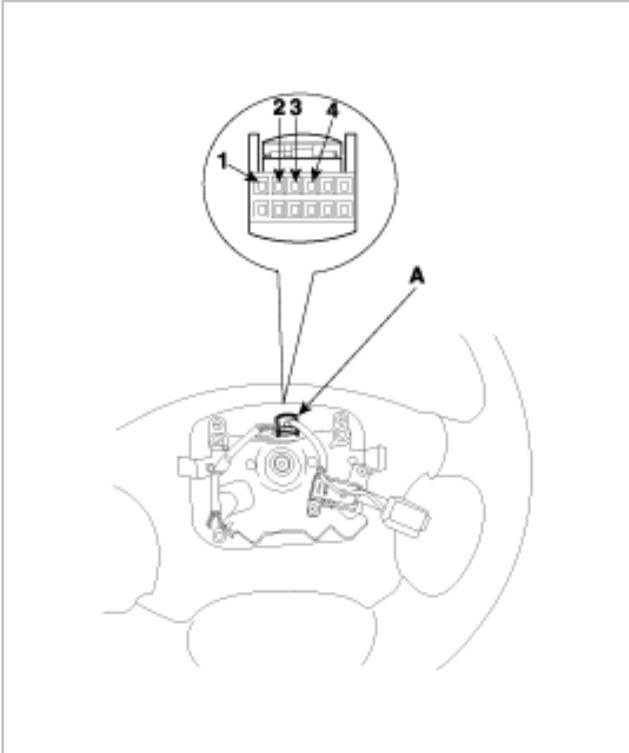

4. Check the continuity between the terminals of the connector in each switch position according to the table.
 - A. If there is continuity, and it matches the table, the switch is O.K.
 - B. If there is no continuity, replace the control switch.

Position \ Terminal	1	2	3	4
MAIN (ON)			○ — ○	
SET (ON)		○ — ○		
RESUME (ON)		○ — ○		
CANCEL (ON)		○ — ○		

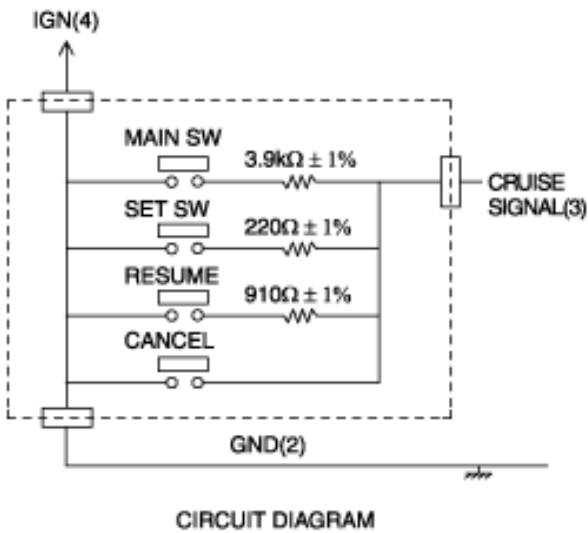

BRAKE SWITCH TEST

1. Disconnect the connector from the brake switch.
2. Remove the brake switch.

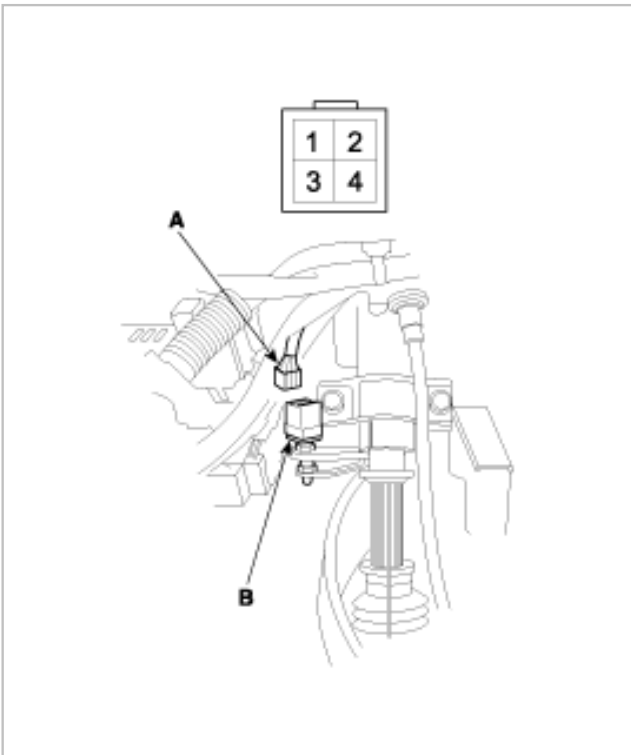

3. Check for continuity between the terminals according to the table.

Terminal	1	2	3	4
Position				
Depressed		○ — ○		
Released	○ — ○		○ — ○	

4. If necessary, replace the switch or adjust the pedal height.
Ebay User ID: reveleus1

ACTUATOR CABLE ADJUSTMENT

1. Check that the actuator cable (A) moves smoothly with no binding or sticking.
2. position, M/T in neutral) until the radiator fan comes on, then let it idle.
3. Measure the amount of movement of the output linkage (B) until the engine speed starts to increase. At first, the output linkage should be located at the fully closed position (C).

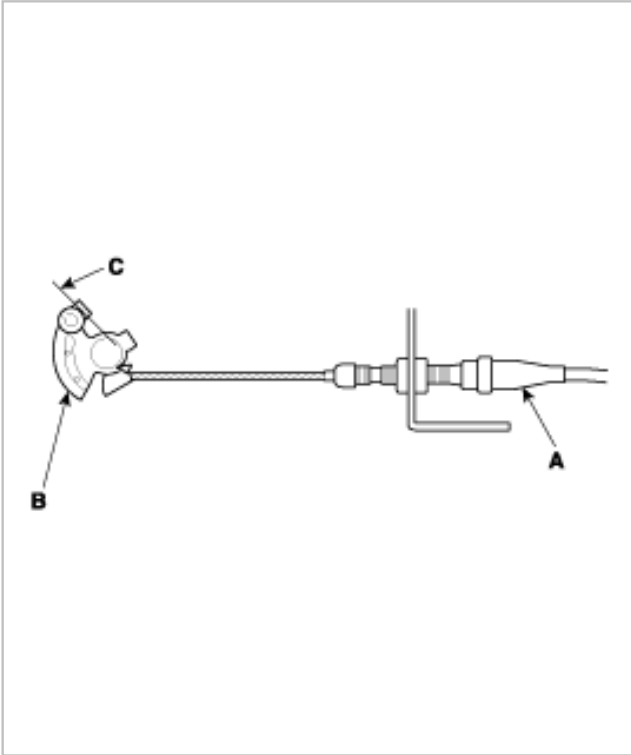

4. If the free play is not within specs, move the cable to the point where the engine speed starts to increase, and tighten the locknut (A) and adjusting nut (B).

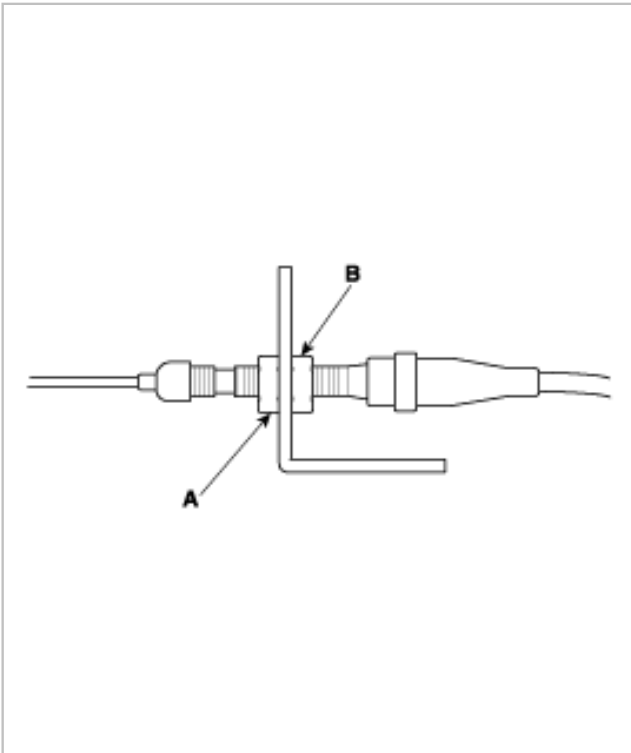

5. Turn the adjusting nut (A) until it is 3.75 ± 0.5 mm (0.15 ± 0.02 in.) away from the bracket (B).
Ebay User ID: reveleus1

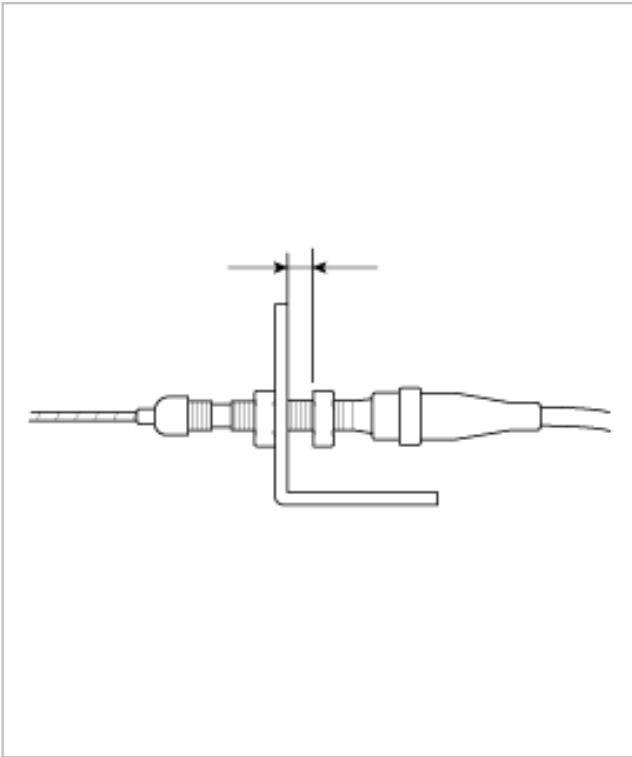

6. Pull the cable assembly so that the adjusting nut (A) touches the bracket, and tighten the locknut (B).

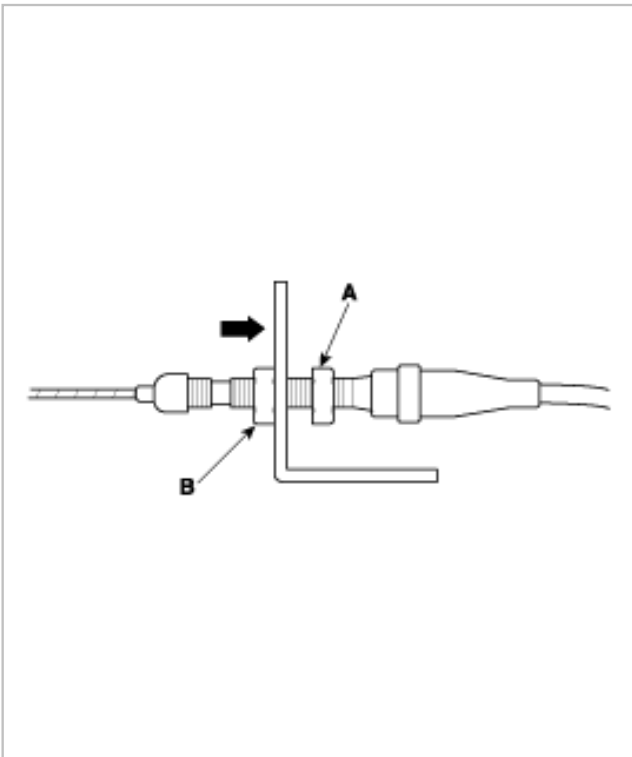

REPLACEMENT

CRUISE CONTROL UNIT AND CABLE

1. Loosen the locknuts(A) and disconnect the actuator cable (B) from the throttle linkage(C).
Ebay User ID: reveleus1

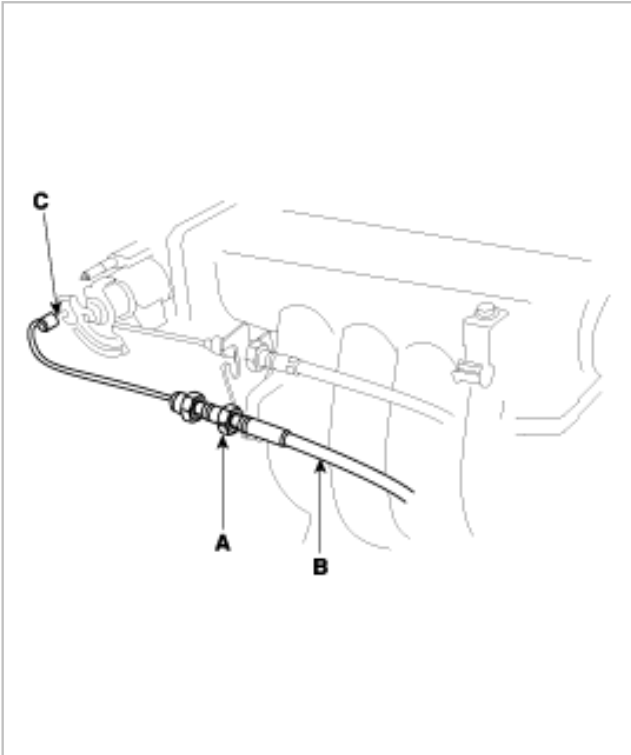

2. Disconnect the cruise control unit connector(D).
3. Loosen the three mounting bolts(E), and remove the cruise control unit with the bracket(F).

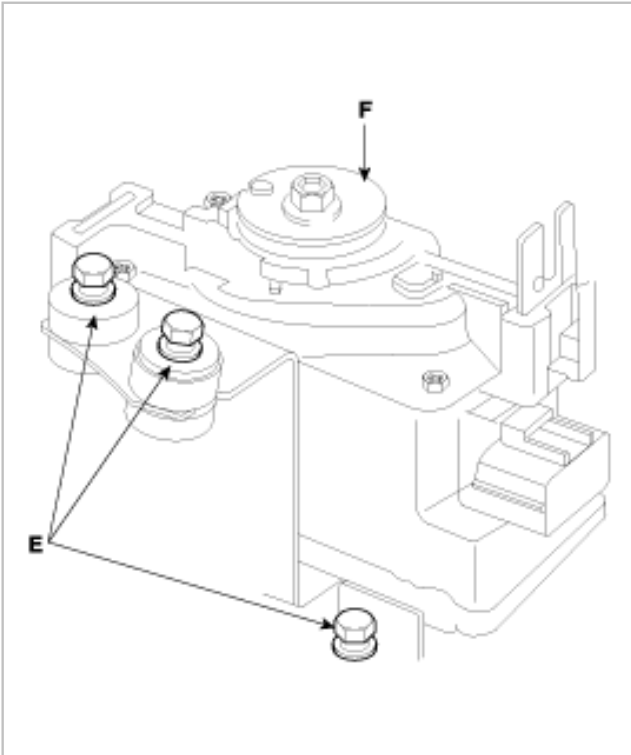

4. Loosen the locknuts(A) and disconnect the actuator cable(B) from the cruise control unit.
Ebay User ID: reveleus1

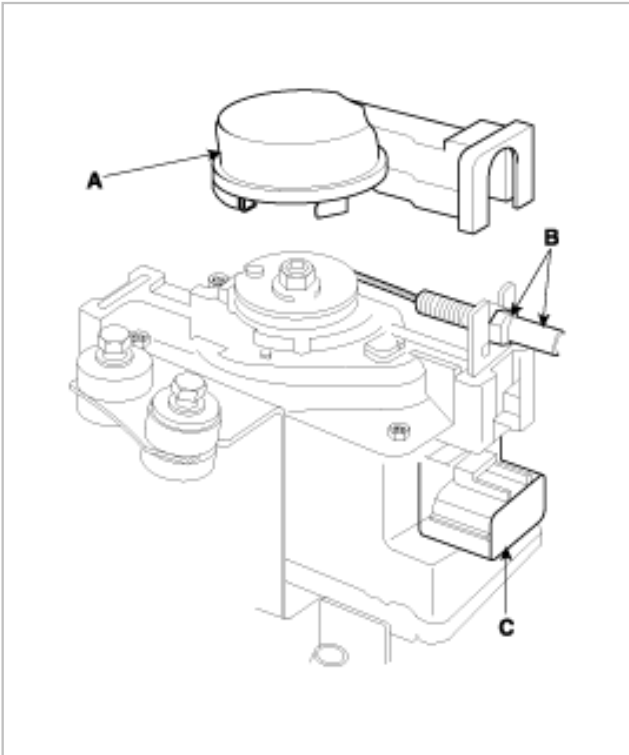

5. Installation is the reverse of removal.

CRUISE CONTROL SWITCH REPLACEMENT

1. Disconnect the battery negative cable, then disconnect the positive cable, and wait at least three minutes.
2. Remove the driver's airbg (See page RT).
3. Disconnect the control switch connector(A).
4. Loosen the two mounting screws(B), and remove the cruise control switch.

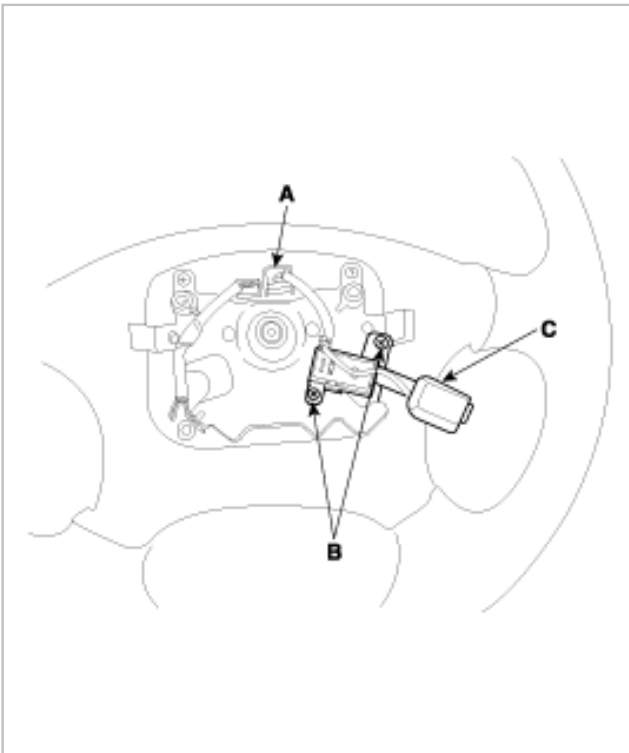

5. Installation is the reverse of removal.

Purchased
from Ebay seller
Reveleus1

Thank-you for purchasing from me, it
is much appreciated.

To contact me please email
suzlever@gmail.com

6. Connect the battery positive cable and negative cable to the battery.

Ebay User ID: reveleus1



CIRCUIT DIAGRAM FOR CRUISE CONTROL SYSTEM

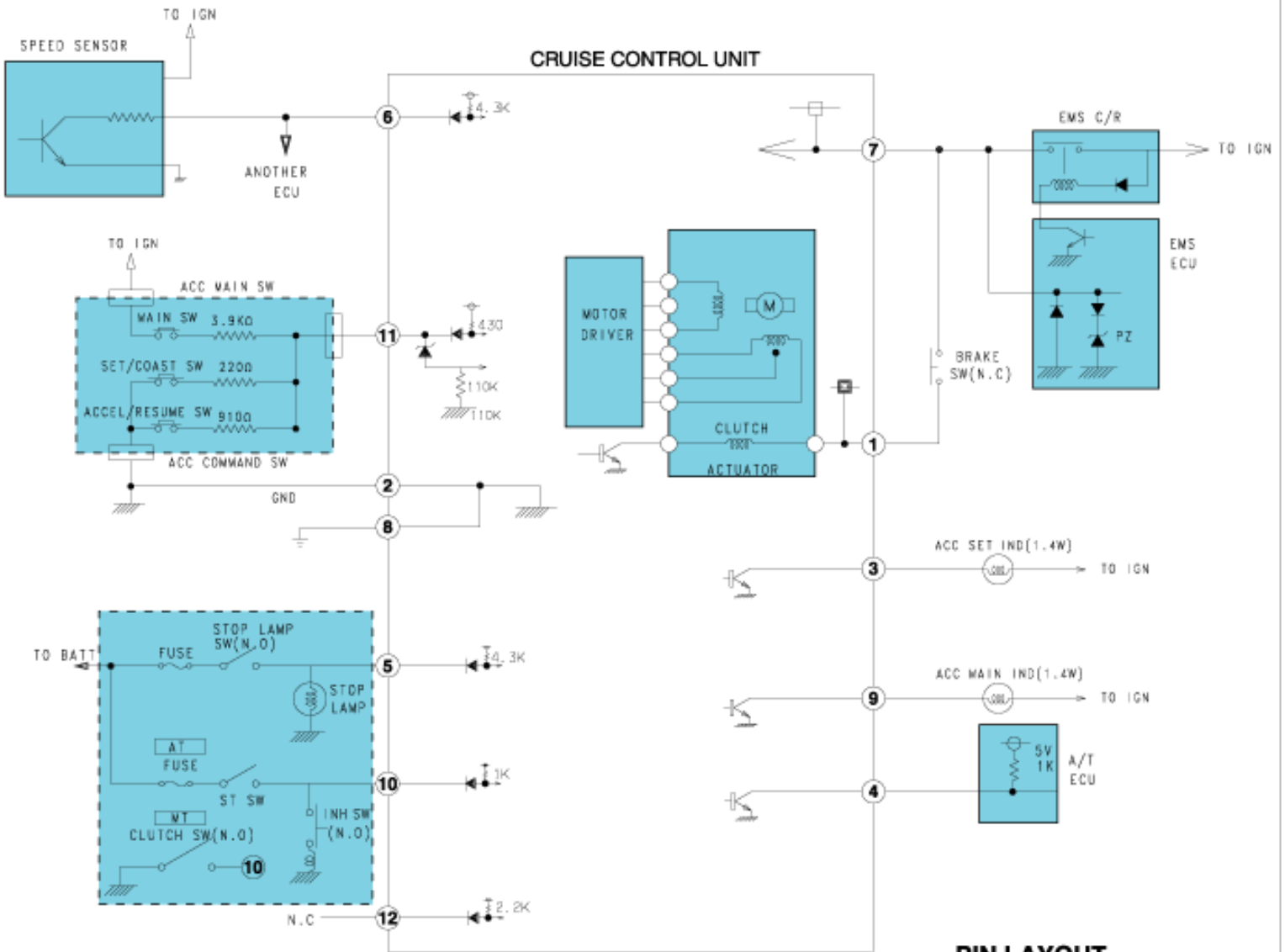

PIN LAYOUT

No	Name	Note
1	BRK	ACTUATOR CLUTCH
2	GND	GROUND
3	SET	SET INDICATOR
4	AT	OD CONTROL
5	STOP	STOP LAMP SW
6	SPD	SPEED SENSOR
7	IGN1	POWER SOURCE
8	GND	GROUND
9	MAIN	MAIN INDICATOR
10	CLU	INH./CLUTCH SW
11	COM	MAIN/COMMAND SW
12	NC	NO CONNECTION

CONNECTOR NO.

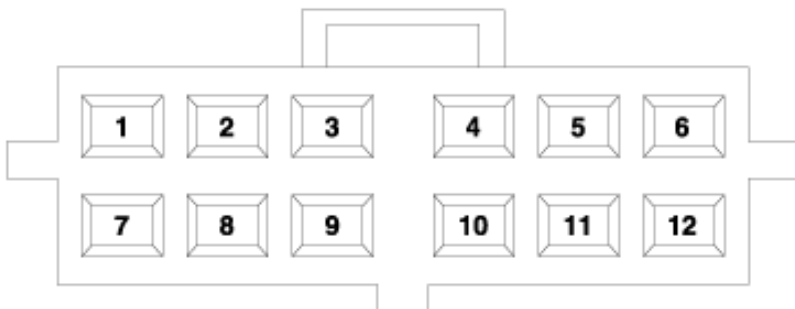

THE MICRO 570 ANALYZER

CAUTION

Because of the possibility of personal injury, always use extreme caution and appropriate eye protection when working with batteries.

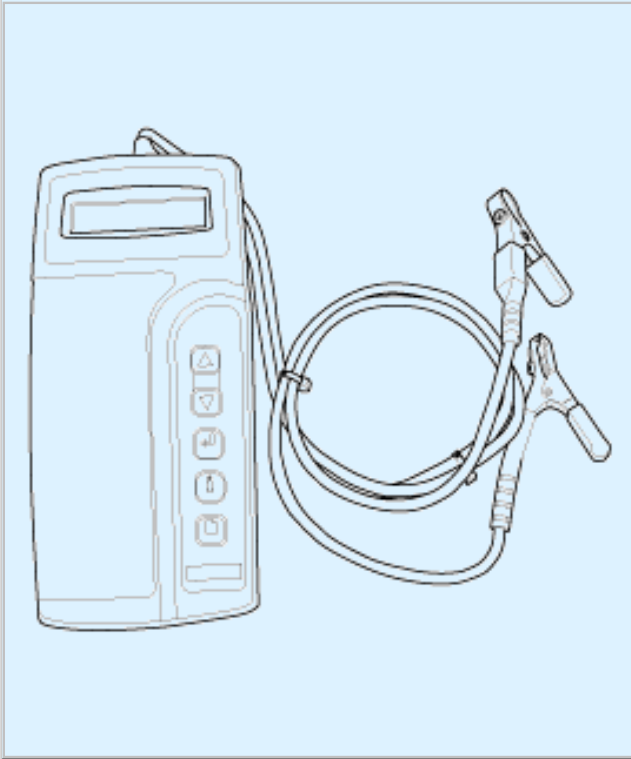

KEYPAD

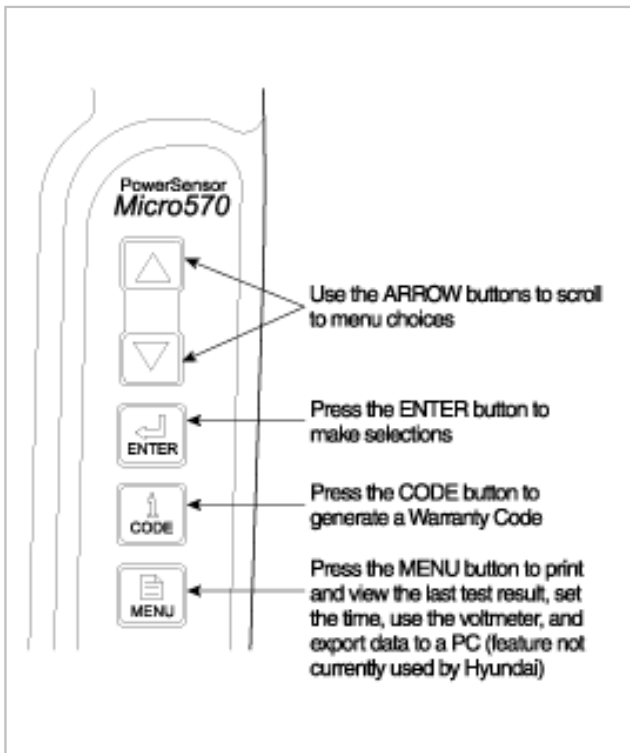

BATTERY TEST PROCEDURE

Ebay User ID: reveleus1

1. Connect the tester to the battery.
 - A. Red clamp to battery positive (+) terminal.
 - B. Black clamp to battery negative (-) terminal.

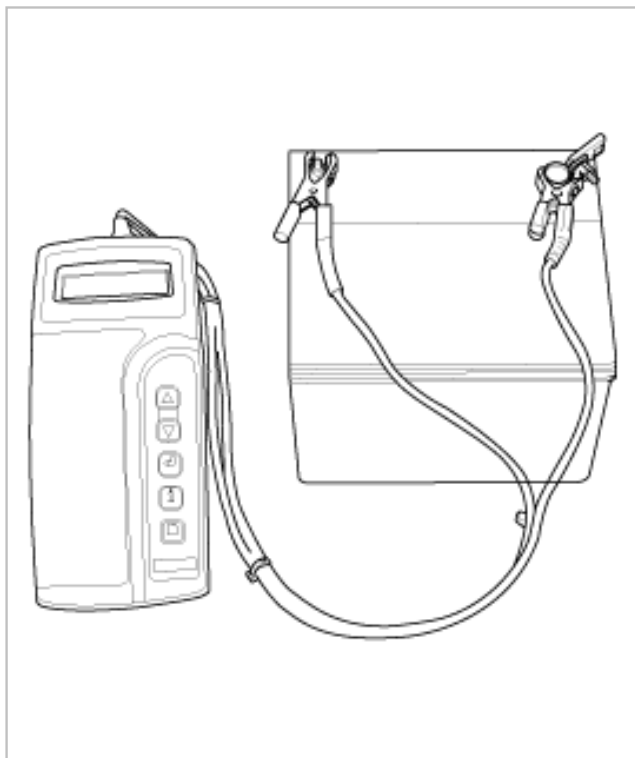

CAUTION

Connect clamps securely. If "CHECK CONNECTION" message is displayed on the screen, reconnect clamps securely.

2. The tester will ask if the battery is connected "IN A VEHICLE" or "OUT OF A VEHICLE".
Make your selection by pressing the arrow buttons; then press ENTER.

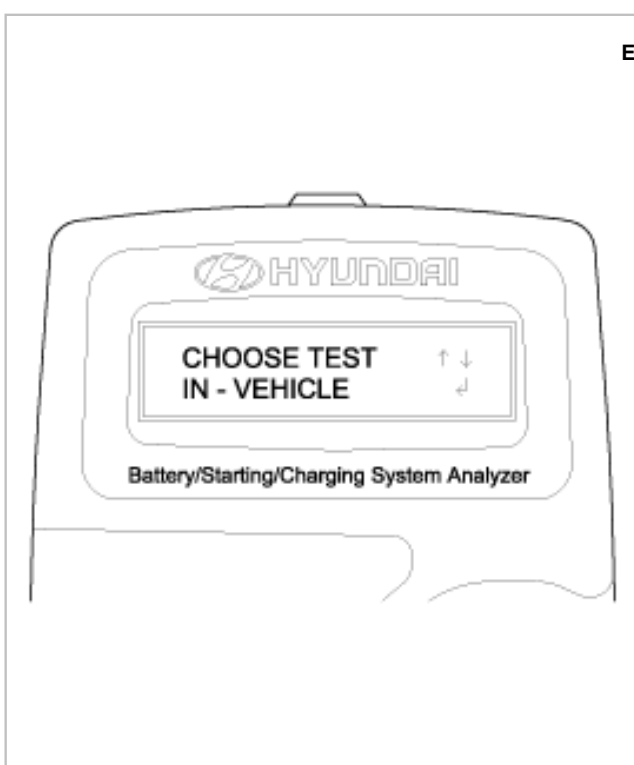

3. Choose either CCA or CCP and press the ENTER button.

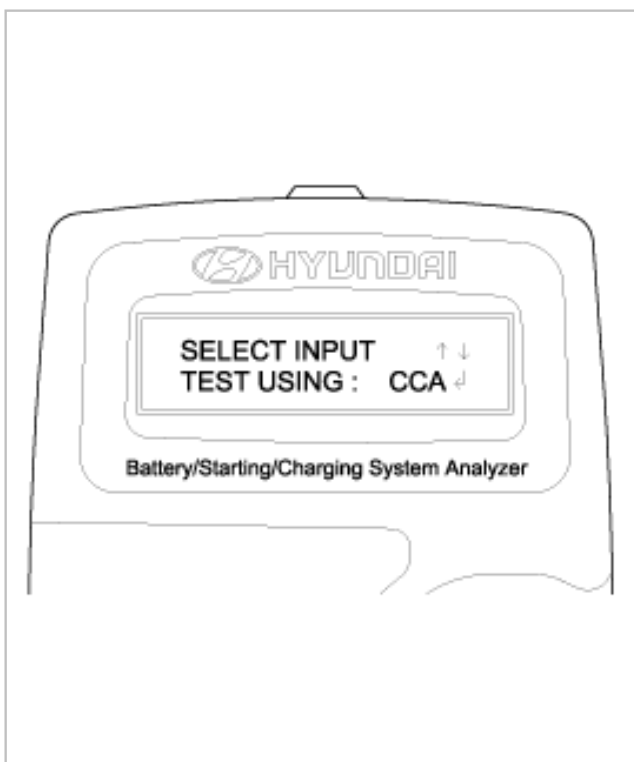

NOTE

- CCA : Cold cranking amps, is an SAE specification for cranking batteries at 0°F (-18°C).
- CCP : Cold cranking power, is an SAE specification for korean manufacturer's for cranking batteries at 0°F (-18°C)

4. Set the CCA value displayed on the screen to the CCA value marked on the battery label by pressing up and down buttons and press ENTER.
Ebay User ID: reveleus1

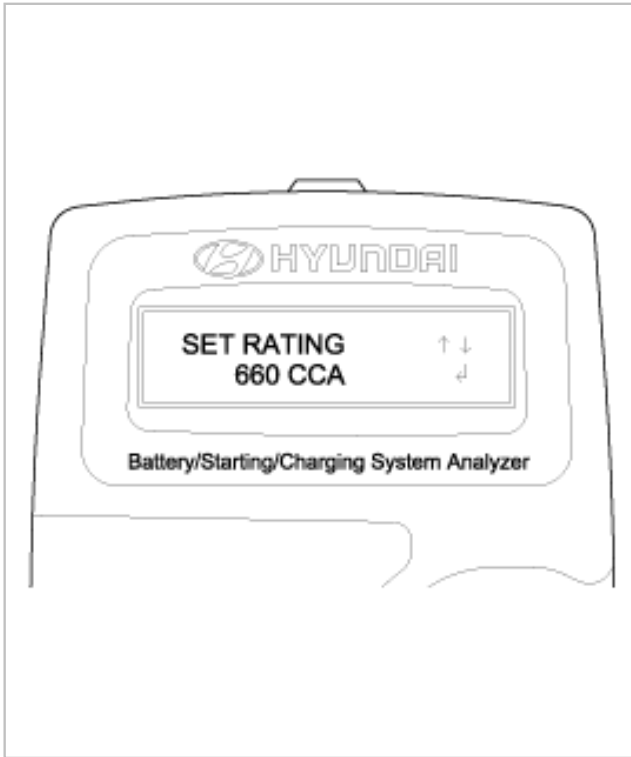

NOTE

The battery ratings(CCA) displayed on the tester must be identical to the ratings marked on the battery label.

5. The tester (Micro570) displays battery test results including voltage and battery ratings.
A relevant action must be taken according to the test results by referring to the battery test results as shown in the table below.



6. To conduct starter test, continuously, press ENTER.
Ebay User ID: reveleus1

BATTERY TEST RESULTS

RESULT ON PRINTER	REMEDY
Good battery	No action is required
Good recharge	Battery is in a good state Recharge the battery and use
Charge & Retest	Battery is not charged properly → Charge and test the battery again (Failure to charge the battery fully may read incorrect measurement value)
Replace battery	→ Replace battery and recheck the charging system. (Improper connection between battery and vehicle cables may cause "REPLACE BATTERY", retest the battery after removing cables and connecting the tester to the battery terminal directly prior to replacing the battery)
Bad cell-replace	→ Charge and retest the battery.

WARNING

Whenever filing a claim for battery, the print out of the battery test results must be attached.

STARTER TEST PROCEDURE

1. After the battery test, press ENTER immediately for the starter test.



2. After pressing ENTER key, start the engine.

Ebay User ID: reveleus1

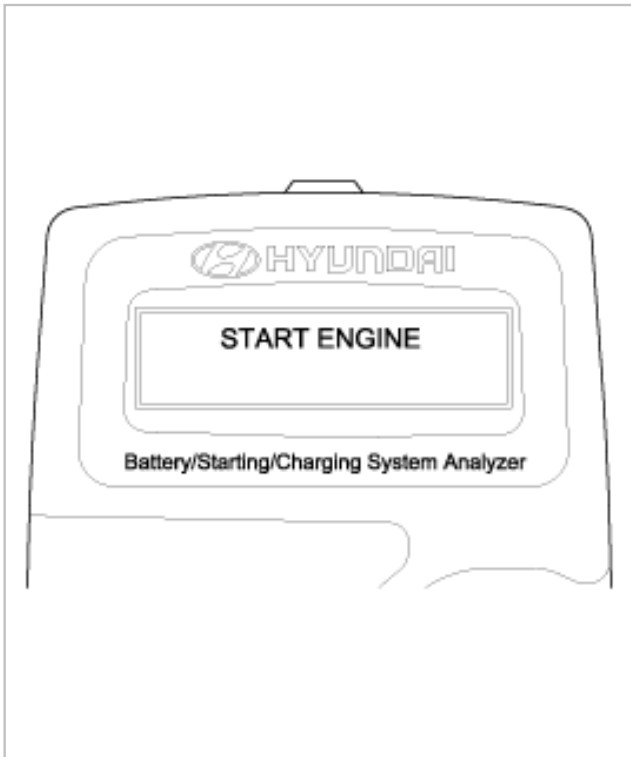

3. Cranking voltage and starter test results will be displayed on the screen.

Take relevant action according to the test results by referring to the starter test results as given below.

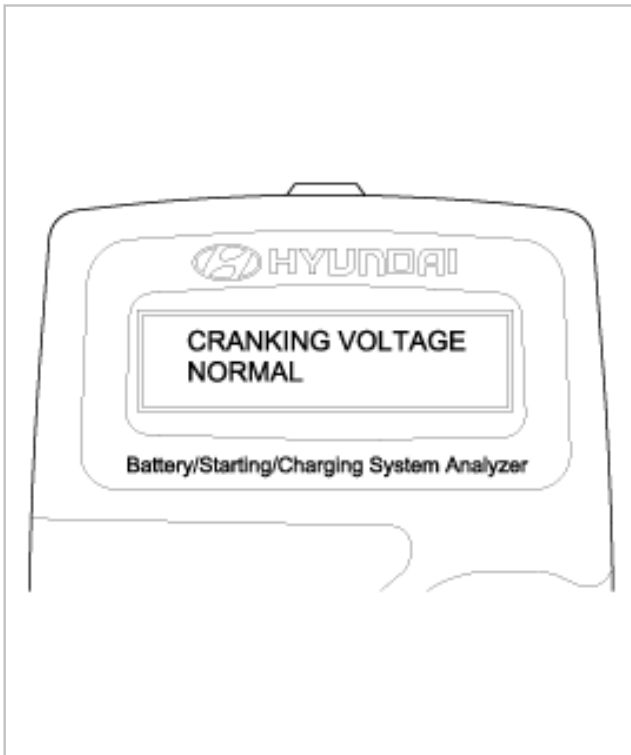

4. To continue charging system test, press ENTER. Ebay User ID: reveleus1

STARTER TEST RESULTS

RESULT ON PRINTER	REMEDY
Cranking voltage normal	System shows a normal starter draw
Cranking voltage low	Cranking voltage is lower than normal level → Check starter
Charge battery	The state of battery charge is too low to test → Charge the battery and retest
Replace battery	→ Replace battery → Check wiring for open circuit, battery cable connection, starter and repair or replace as necessary. → If the engine does crank, check fuel system.

CHARGING SYSTEM TEST PROCEDURE

1. Press ENTER to begin charging system test.

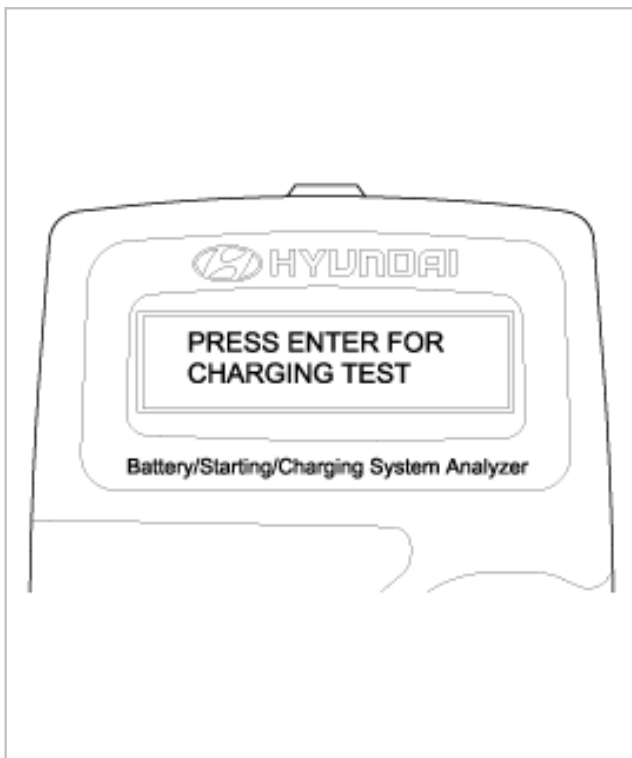

2. If ENTER button is pressed, the tester displays the actual voltage of alternator.

Ebay User ID: reveleus1

Press ENTER to test the charging system.

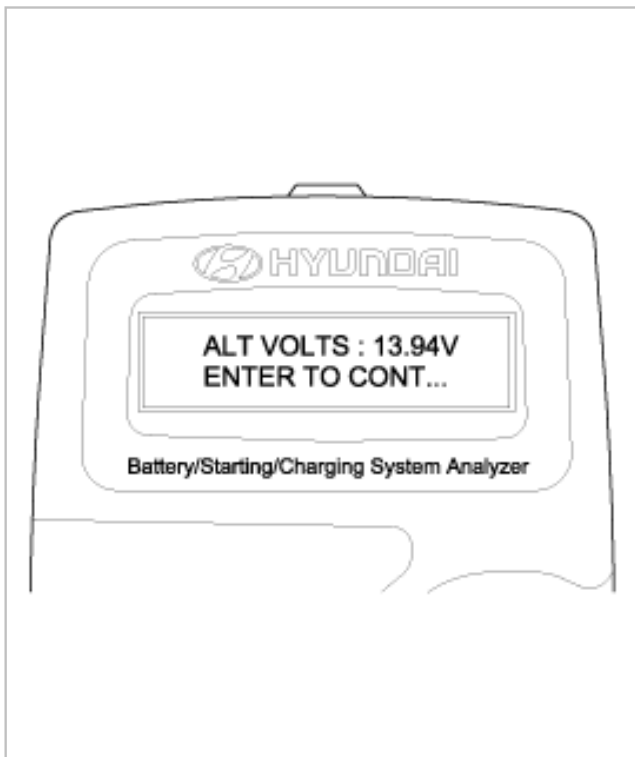

3. Turn off all electrical load and rev engine for 5 seconds.

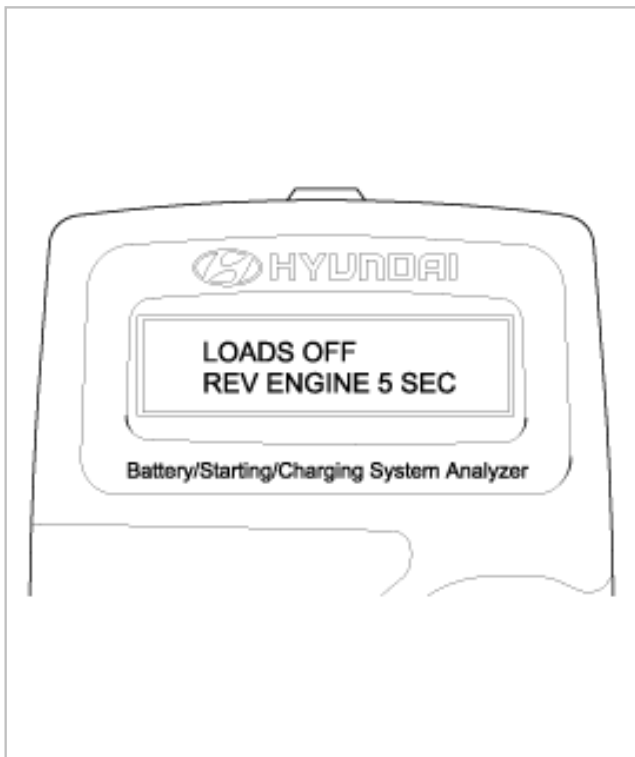

4. Press ENTER.

Ebay User ID: reveleus1

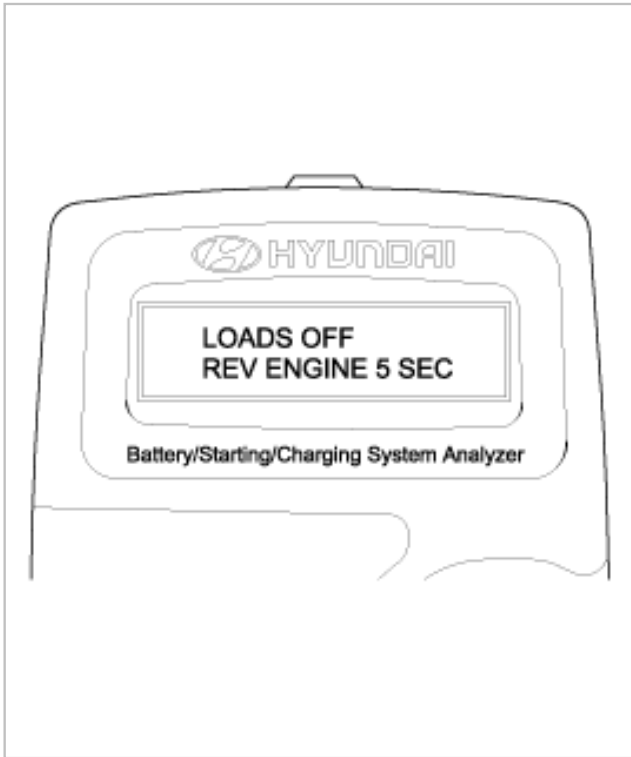

5. The MICRO 570 analyzer charging system output at idle for comparison to other readings.

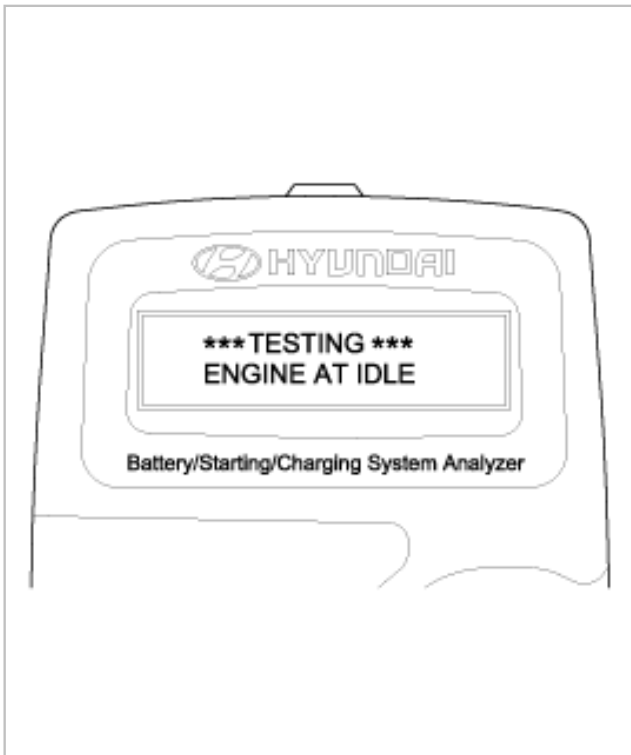

6. Take relevant action according to the test results by referring to the table below after shutting off the engine and disconnect the tester clamps from the battery. Ebay User ID: revefeus1

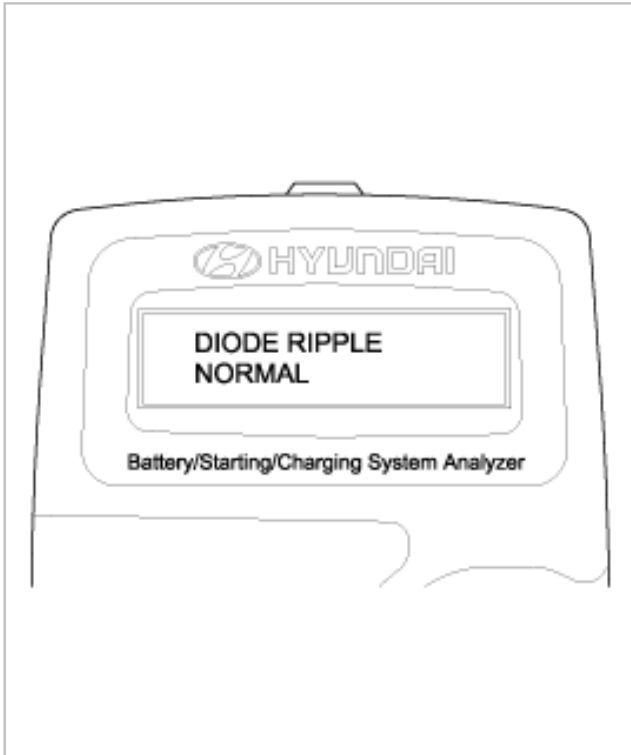

CHARGING SYSTEM TEST RESULTS

RESULT ON PRINTER	REMEDY
Charging system normal/Diode ripple normal	Charging system is normal
No charging voltage	Generator does not supply charging current to battery → Check belts, connection between generator and battery Replace belts or cable or generator as necessary
Low charging voltage	Generator does not supply charging current to battery and electrical load to system fully → Check belts and generator and replace as necessary
High charging voltage	The voltage from generator to battery is higher than normal limit during voltage regulating. → Check connection and ground and replace regulator as necessary
Excess ripple detected	One or more diodes in the generator is not functioning properly → Check generator mounting and belts and replace as necessary



ON-VEHICLE INSPECTION

INSPECT SPARK TEST

1. Remove the spark plug cable.
2. Using a spark plug socket, remove the spark plug.
3. Install the spark plugs to each spark plug cable.
4. Ground the spark plugs.
5. Check if spark occurs while engine is being cranked.

NOTE

To prevent gasoline from being injected from injectors during this test, disconnect the injector connectors.
Be sure to clean away DTC codes the timing is complete after.

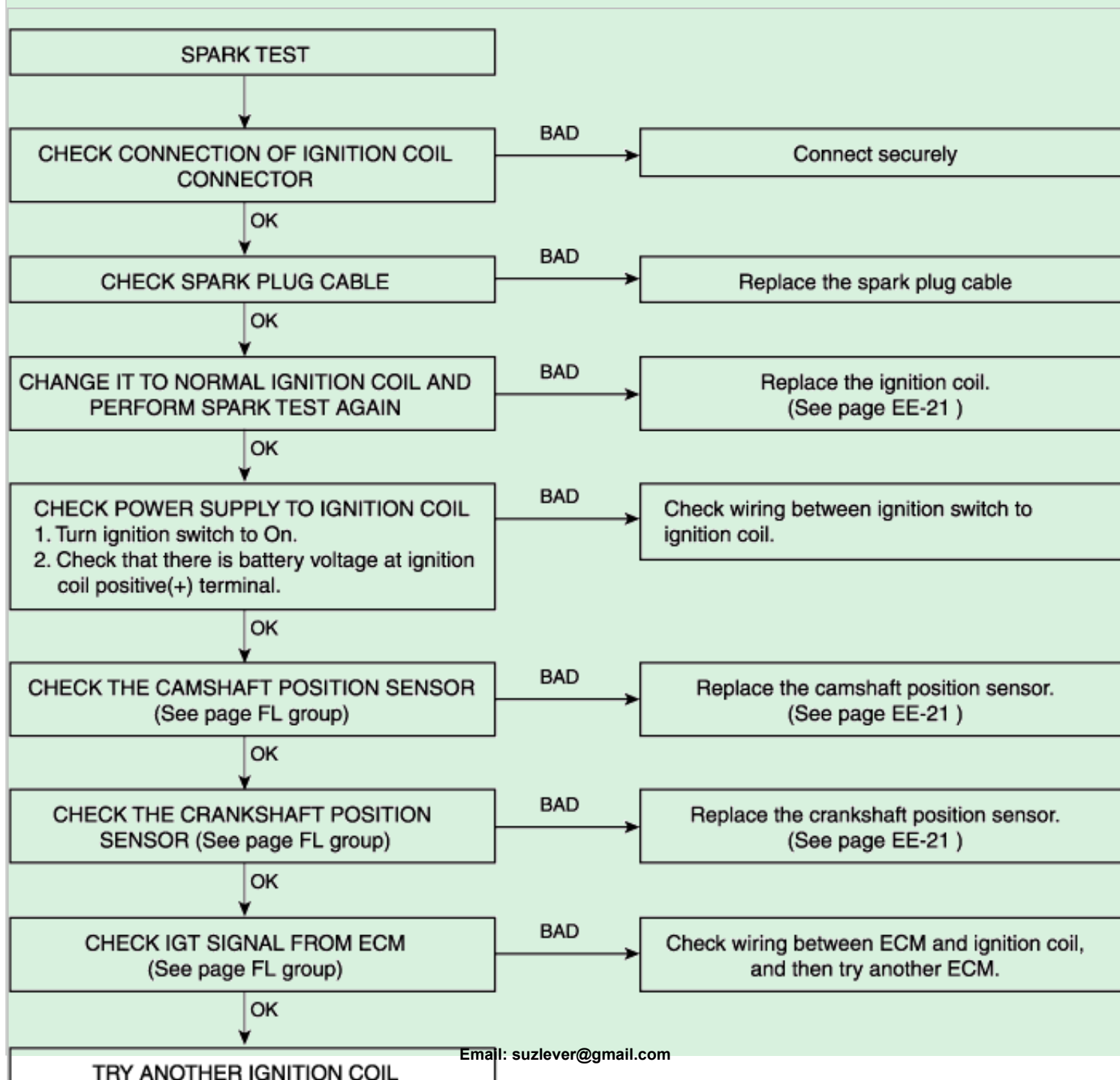

- Using a spark plug socket, install the spark plugs.
- Install the spark plug cable.

INSPECT SPARK PLUG AND SPARK PLUG CABLE

- Remove the spark plug cable(A).

NOTE

When removing the spark plug cable, pull on the spark plug cable boot (not the cable), as it may be damaged.

- Using a spark plug socket, remove the spark plug(B).

CAUTION

Be careful that no contaminants enter through the spark plug holes.

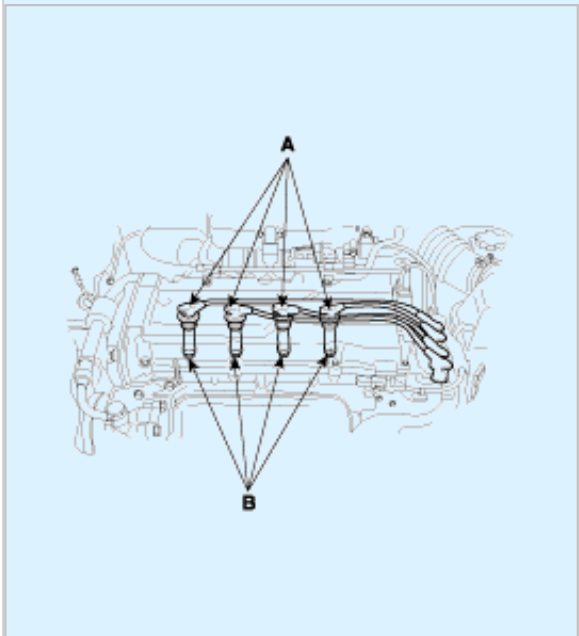

- Inspect the electrodes(A) and ceramic insulator(B).

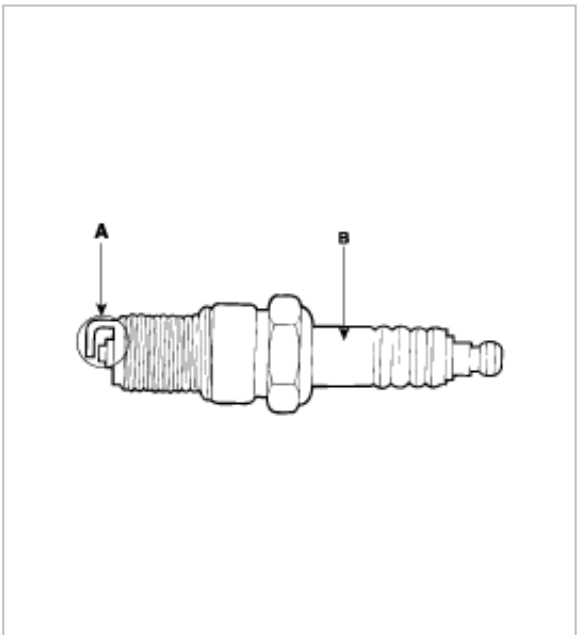

INSPECTION FO ELECTRODES

CONDITION	DARK DEPOSITS	WHITE DEPOSITS
DESCRIPTION	-Fuel mixture too rich -Low air intake	-Fuel mixture too lean -Advanced ignition timing -Insufficient plug tightening

4. Check the electrode gap(A).

Standard (New)

1.0~1.1 mm (0.039~0.043 in.)

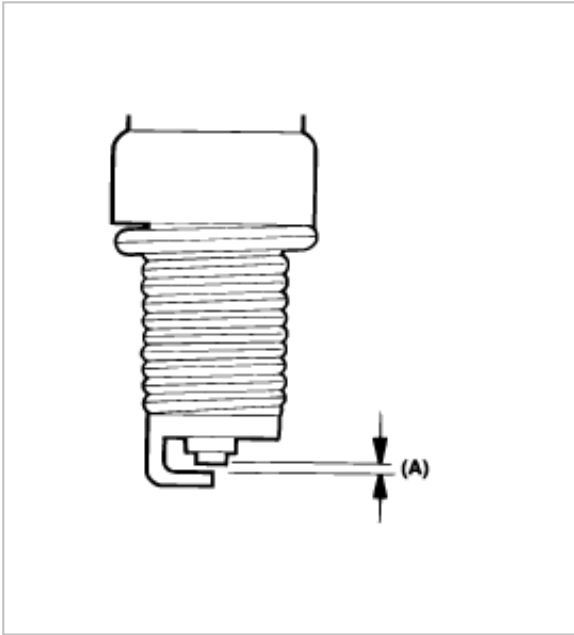

5. Carefully remove the spark plug cable by pulling on the rubber boots(A).

Check the condition of the spark plug cable terminals(B), If any terminal is corroded, clean it, and if it's broken or distorted, replace the spark plug cable.

6. Connect the ohmmeter probes and measure resistance.

RESISTANCE : 5.6K /m ± 20%

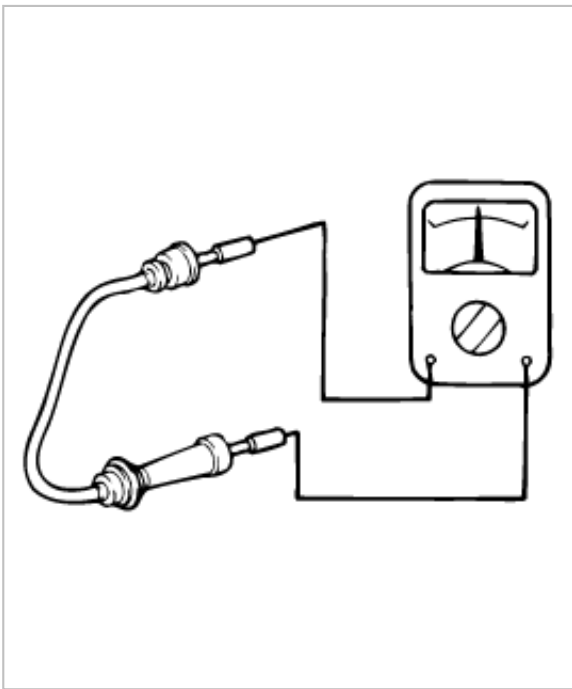

7. Resistance should not be higher than 2.6k per meter of cable.
If resistance is higher, replace the cable.

INSPECT IGNITION COIL

1. Measure the primary coil resistance between terminals 1, 2 and 1,3.

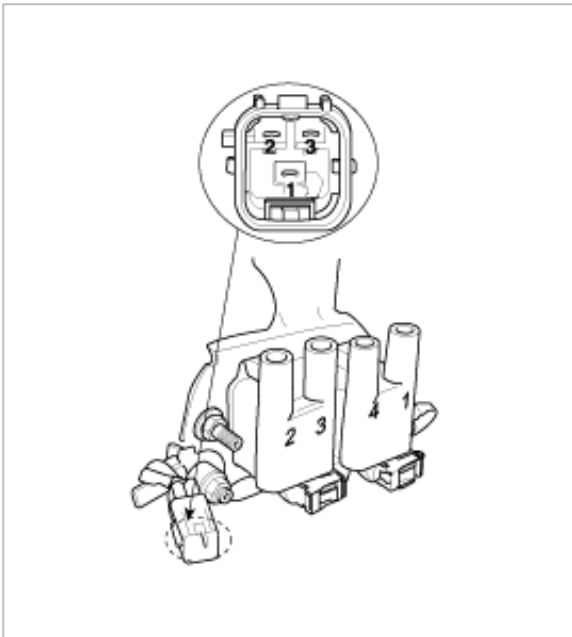

Standard value : 0.58 \pm 10%

2. Measure the secondary coil resistance between the high-voltage terminal for the No.1 and No.4 cylinders, and between the high-voltage terminals for the No.2 and No.3 cylinders.

Ebay User ID: reveleus1

Standard value : 8.8k ± 15%

CAUTION

Be sure, when measuring the resistance of the secondary coil, to disconnect the connector of the ignition coil.

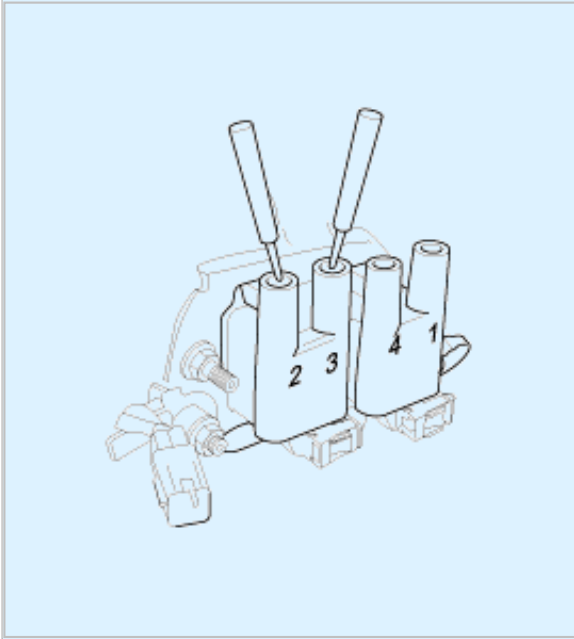

INSPECT IGNITION SWITCH

1. Remove the connector located under the steering column.
2. Check for continuity between terminals.

If there is no continuity, replace the ignition switch.

TERMINAL POSITION KEY		IGNITION SWITCH						STEERING		KEY WARNING SWITCH		KEY ILLUMINATION SWITCH	
		5	3	1	2	4	6	TRAVEL	TRAVEL	3	4	1	2
LOCK	REMOVAL							LOCK					
	INSERT							LOCK	UNLOCK				
ACC		○—○						UNLOCK					
ON		○—○—○			○—○					○—○			
START		○—○—○			○—○—○								

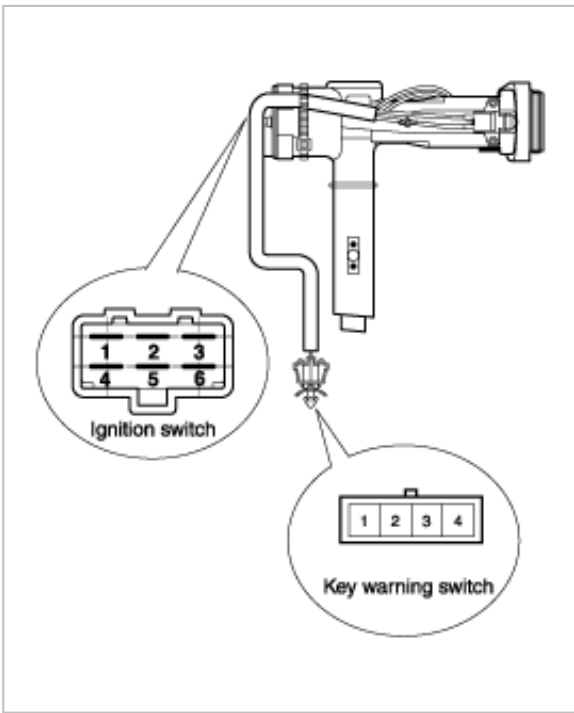

REPLACEMENT

IGNITION COIL

1. Remove the engine cover.
2. Disconnect the spark plug cable and connector.
3. Remove the ignition coil.
4. Installation is the reverse of removal.

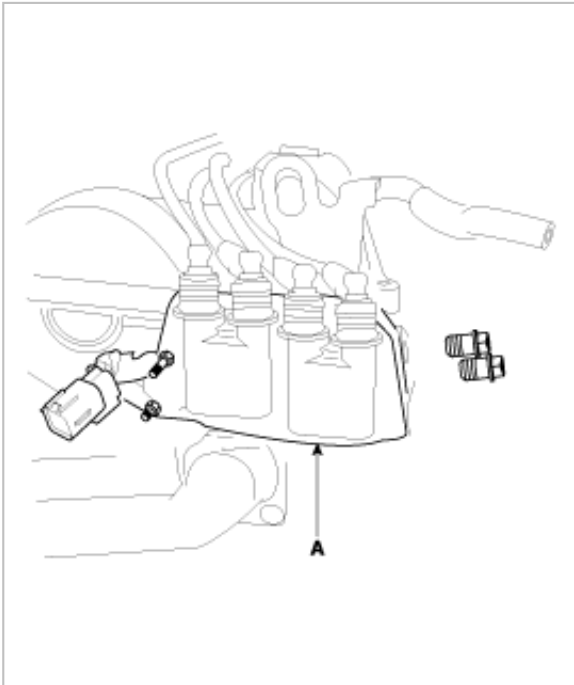

CRANKSHAFT POSITION SENSOR

1. Disconnect the crankshaft position sensor connector.
2. Remove the crankshaft position sensor(A).

CAMSHAFT POSITION SENSOR

1. Remove the engine cover(B).

2. Disconnect the camshaft position sensor connector.

Ebay User ID: reveleus1

3. Remove the camshaft position sensor(C).

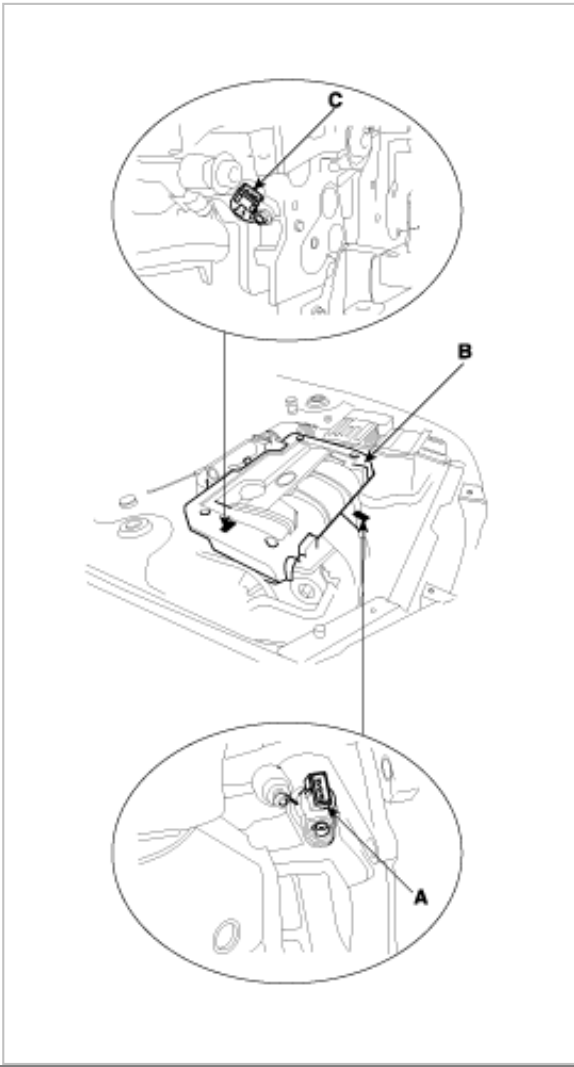



SPECIFICATION

IGNITION SYSTEM

Items	Specifications
Ignition coil Type Primary resistance Secondary resistance	Mold coil type $0.58 \pm 10\%$ () $8.8 \pm 15\%$ (k)
Spark plugs NGK CHAMPION Gap	BKR5ES-11 RC10YCPB4 1.0 ~ 1.1 mm (0.039 ~ 0.043 in.)

STARTING SYSTEM

Items	Specifications
Starter Type Rated voltage No. of pinion teeth No-load characteristics Voltage Amperage Speed Commutator diameter Standard Limit Undercut depth Standard Limit	Reduction drive (with planetary gear) 12V, 1.2KW 8 11V 90A, Max. 3,000 rpm, Min. 29.4 mm (1.157 in.) 28.4 mm (1.118 in.) 0.5 mm (0.02 in.) 0.2 mm (0.008 in.)

CHARGING SYSTEM

Items	Specifications
-------	----------------

Generator	Ebay User ID: reveleus1	Battery voltage sensing
Type		13.5V, 90A
Rated voltage		1000 ~ 18,000 rpm
Speed in use		Electronic built-in type
Voltage regulator		14.4 ± 0.2V
Regulator setting voltage		-10 ± 3 mV/°C
Temperature compensation		
Battery		MF60AH
Type		550A
Cold cranking amperage [at -18°C (0°F)]		92min
Reserve capacity		1,280 ± 0.01
Specific gravity [at 25°C (77°F)]		

NOTE

- COLD CRANKING AMPERAGE is the amperage a battery can deliver for 30 seconds and maintain a terminal voltage of 7.2V or greater at a specified temperature.
- REVERSE CAPACITY RATING is the amount of time a battery can deliver 25A and maintain a minimum terminal voltage of 10.5V at 26.7°C(80°F)

AUTO CRUISE CONTROL SYSTEM

Items	Specification
Setting error	Within ± 1.5Km/h on level road (± 1MPH)
Vehicle speed memory variation	No variation
Setting time	0.1sec max.
Resuming time	0.1sec max.
Minimum operating speed	40 ± 2Km/h (25 ± 1.2MPH)
Cancel speed range	15 ± 2Km/h (9 ± 1.2MPH)
Maximum memorized speed	160 ± 2Km/h (99 ± 1.2MPH)
Pulling force	127N(13Kgf)(28.6 lb-force)
Main switch serial resistance value	3.9k ± 1%
Command switch serial resistance value	SET switch : 220 ± 1%
	RESUME switch : 910 ± 1%

TIGHTENING TORQUE

Items	Nm	kg·cm	lb·ft

Generator terminal (B+)	Ebay User ID:reveleus1 5 ~ 7	50 ~ 70	3.6 ~ 5.1
Starter motor terminal (B+)	10 ~ 12	100 ~ 120	7.3 ~ 8.8
Battery terminal	4 ~ 6	40 ~ 60	2.9 ~ 4.3
Spark plug	20 ~ 30	200 ~ 300	15 ~ 22

COMPONENTS

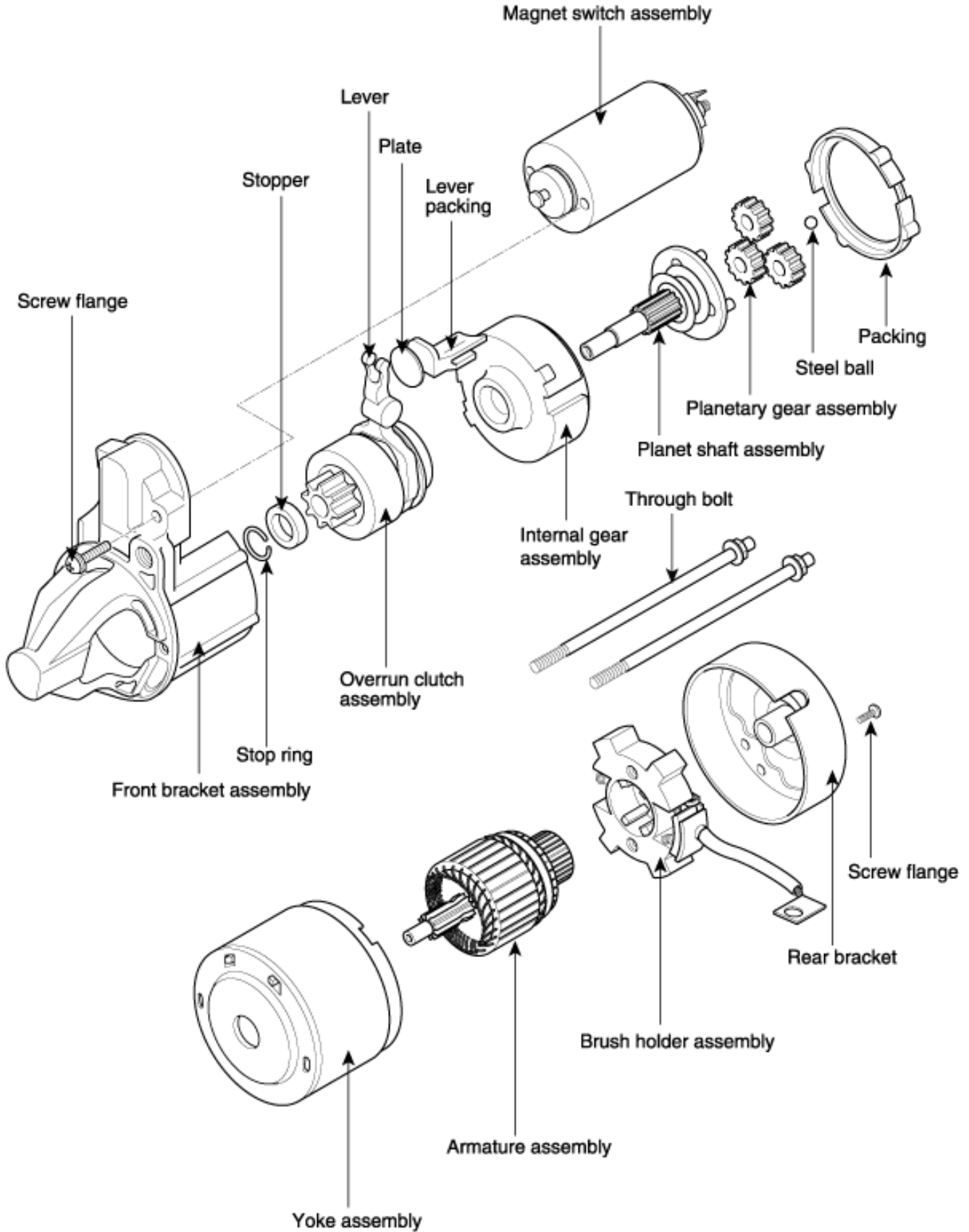

INSPECTION

1. Remove the fuse box cover.
2. Remove the starter relay.

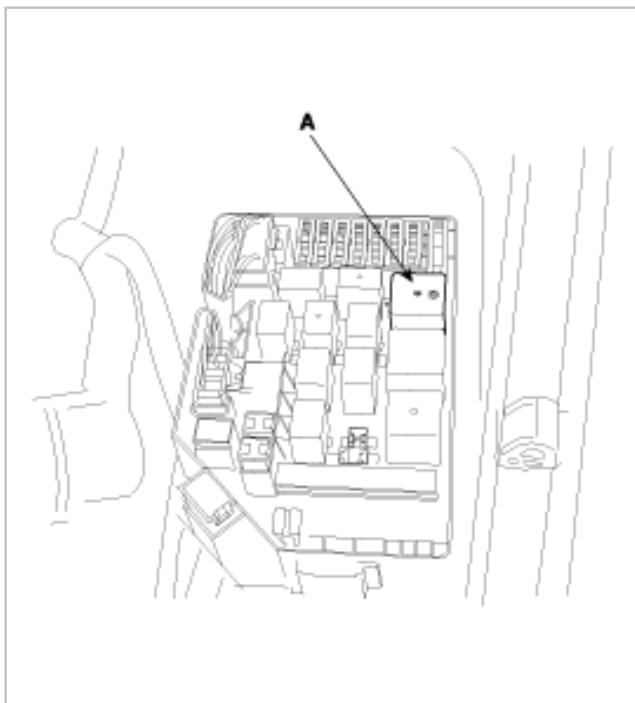

3. Inspect the relay continuity.

A. Using an ohmmeter, check that there is continuity between terminals 2 and 4.

If there is no continuity, replace the relay.

B. Check that there is no continuity between terminals 1 and 5.

If there is continuity, replace the relay.

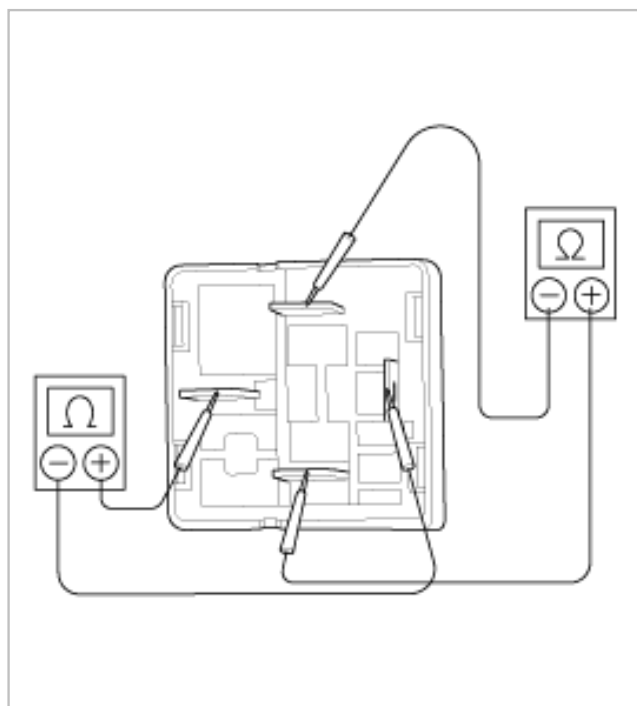

4. Inspect the relay operation.

Ebay User ID: reveleus1

A. Apply battery positive voltage across terminals 2 and 4.

B. Using an ohmmeter, check that there is continuity between terminals 1 and 5.

If there is no continuity, replace the relay.

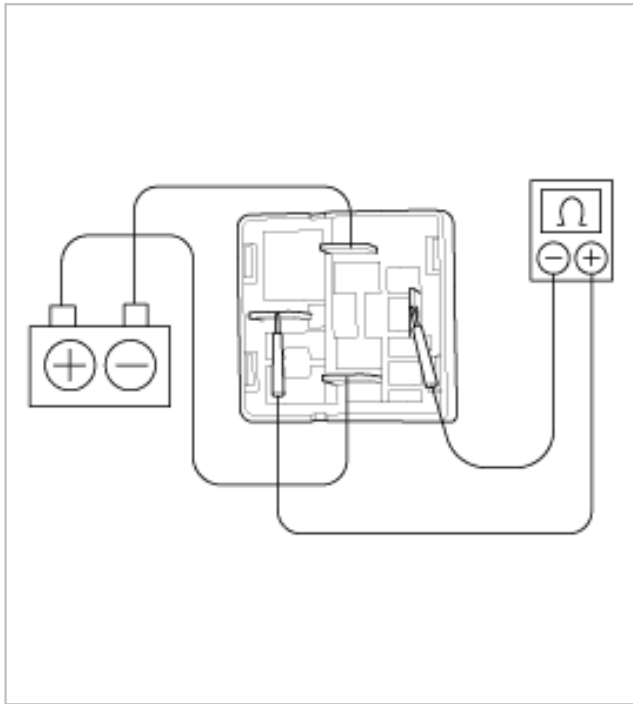

5. Install the starter relay.

6. Install the fuse box cover.



REPLACEMENT

1. Disconnect the battery negative cable.
2. Disconnect the starter cable(A) from the B terminal(B) on the solenoid(C), then disconnect the connecto(D) from the S terminal(E).

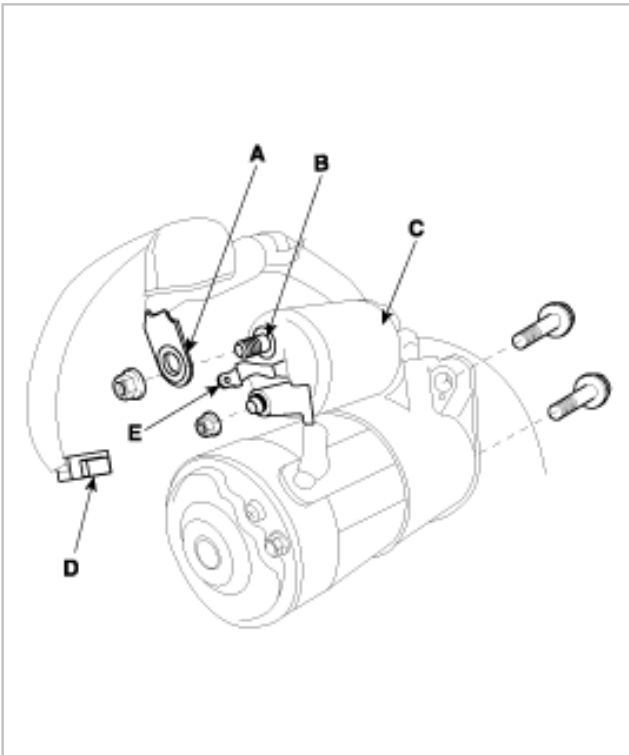

3. Remove the 2 bolts holding the starter, then remove the starter.
4. Installation is the reverse of removal.
5. Connect the battery negative cable to the battery.

DESCRIPTION

The starting system includes the battery, starter motor, solenoid switch, ignition switch, inhibitor switch(A/T), ignition lock switch, connection wires and the battery cable.

When the ignition key is turned to the start position, current flows and energizes the starter motor's solenoid coil.

The solenoid plunger and clutch shift lever are activated, and the clutch pinion engages the ring gear.

The contacts close and the starter motor cranks. In order to prevent damage caused by excessive rotation of the starter armature when the engine starts, the clutch pinion gear overruns.

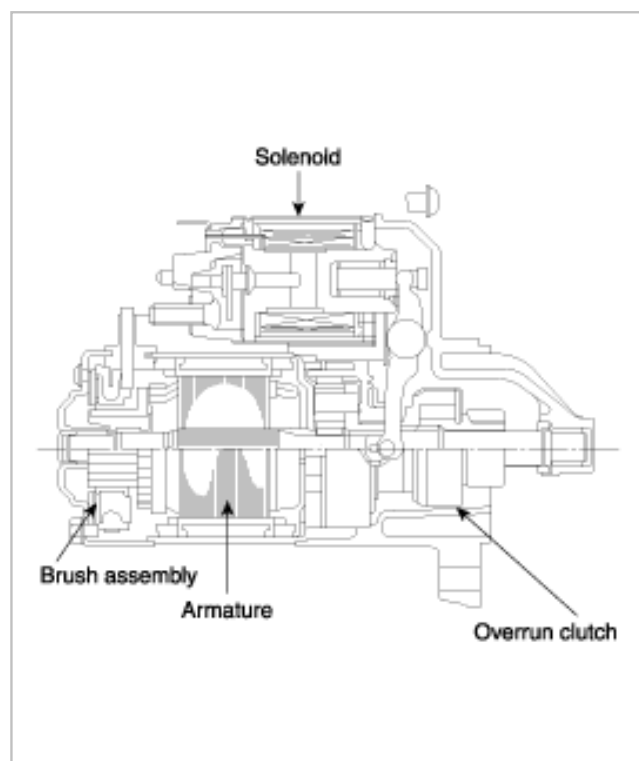



INSPECTION

START TEST

NOTE

The air temperature must be between 59 and 100°F (15 and 38°C) before testing.

Recommended procedure :

- Use a starter system tester.
- Connect and operate the equipment in accordance with the manufacturer's instructions.
- Test and troubleshoot as described.

Alternate Procedure :

- Use the following equipment :
 - Ammeter, 0~400A
 - Voltmeter, 0~20V (accurate within 0.1 volt)
 - Tachometer, 0~1,200 rpm

NOTE

After this test, or any subsequent repair, reset the ECM/PCM to clear any codes.

Check the Starter Engagement :

1. Remove the No.8(10A) fuse from the fuse/relay box.
2. Turn the ignition switch to START (III) with the shift lever in "P" or " N" position (A/T) or with the clutch pedal depressed (M/T). The starter should crank the engine.
 - A.If the starter does not crank the engine, go to step 3.
 - B.If it cranks the engine erratically or too slowly, go to "Check for Wear and Damage" on the next page.
3. Check the battery, battery positive cable, ground, starter cut relay, and the wire connections for looseness and corrosion. Test again.

If the starter still does not crank the engine, go to step 4.
4. Unplug the connector from the starter.
5. Connect a jumper wire from the battery positive (+) terminal to the solenoid terminal.

The starter should crank the engine.

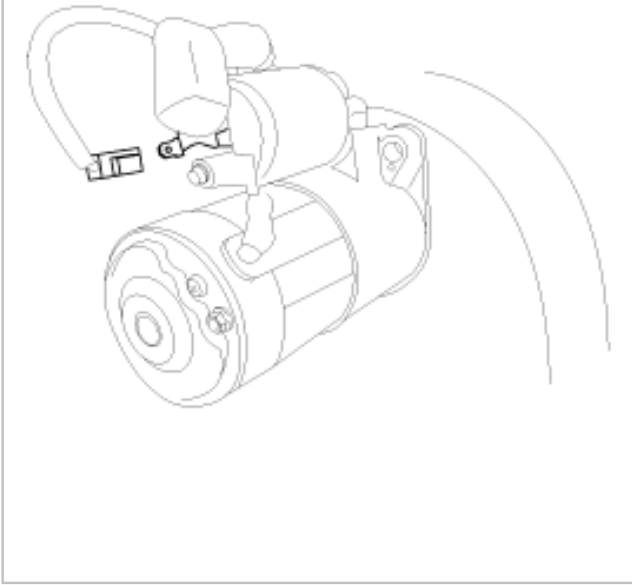

A. If the starter still does not crank the engine, remove it, and diagnose its internal problem.

B. If the starter cranks the engine, go to step 6.

6. Check the ignition switch (see page EE-20).
7. Check the starter relay (see page EE-46).
8. Check the A/T gear position switch (A/T) or the clutch interlock switch (M/T).
9. Check for an open in the wire between the ignition switch and starter.

If cranking voltage is too low, or current draw too high, check for :

- dead or low battery.
- open circuit in starter armature commutator segments.
- starter armature dragging.
- shorted armature winding.
- excessive drag in engine.

Check Cranking rpm

Engine speed during cranking should be above 100 rpm.

If speed is too low, check for :

- loose battery or starter terminals.
- excessively worn starter brushes.
- open circuit in commutator segments.
- dirty or damaged helical splines or drive gear.
- defective drive gear overrunning clutch.

Check starter disengagement

With the shift lever in N or P position (A/T) or with the clutch pedal depressed (M/T), turn the ignition switch to START(III), and release to ON(II).

The starter drive gear should disengage from the flywheel or flywheel ring gear when you release the key.

If the drive gear hangs up on flywheel ring gear, check for :

- solenoid plunger and switch malfunction. Ebay User ID: reveleus1
- dirty drive gear assembly or damaged overrunning clutch.

STARTER SOLENOID TEST

1. Check the hold-in coil for continuity between the S terminal and the armature housing (ground). The coil is OK if there is continuity.

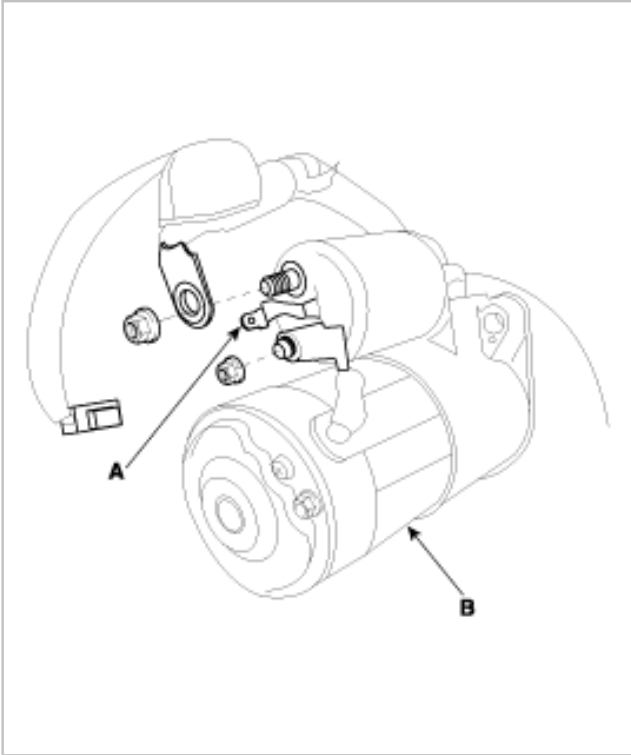

2. Check the pull-in coil for continuity between the S and M terminals. The coil is OK if there is continuity.

FREE RUNNING TEST

1. Place the starter motor in a vise equipped with soft jaws and connect a fully-charged 12-volt battery to starter motor as follows :
2. Connect a test ammeter (100-ampere scale) and carbon pile rheostatas shown in the illustration.
3. Connect a voltmeter (15-volt scale) across the starter motor.
4. Rotate carbon pile to the off position.
5. Connect the battery cable from battery's negative post to the startermotor body.
6. Adjust the carbon pile until battery voltage shown on the voltmeter reads 11 volts.
7. Confirm that the maximum amperage is within the specifications and that the starter motor turns smoothly and freely :

: Max. 90 Amps

: Min. 2,800 rpm

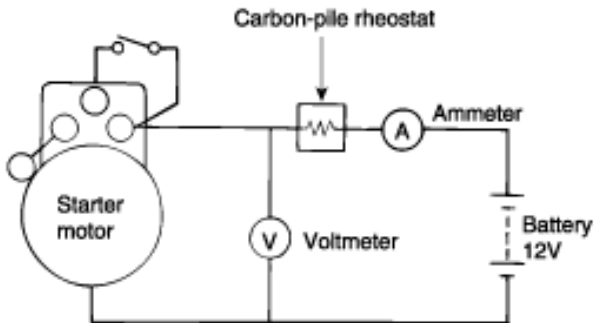

CIRCUIT DIAGRAM FOR STARTING SYSTEM

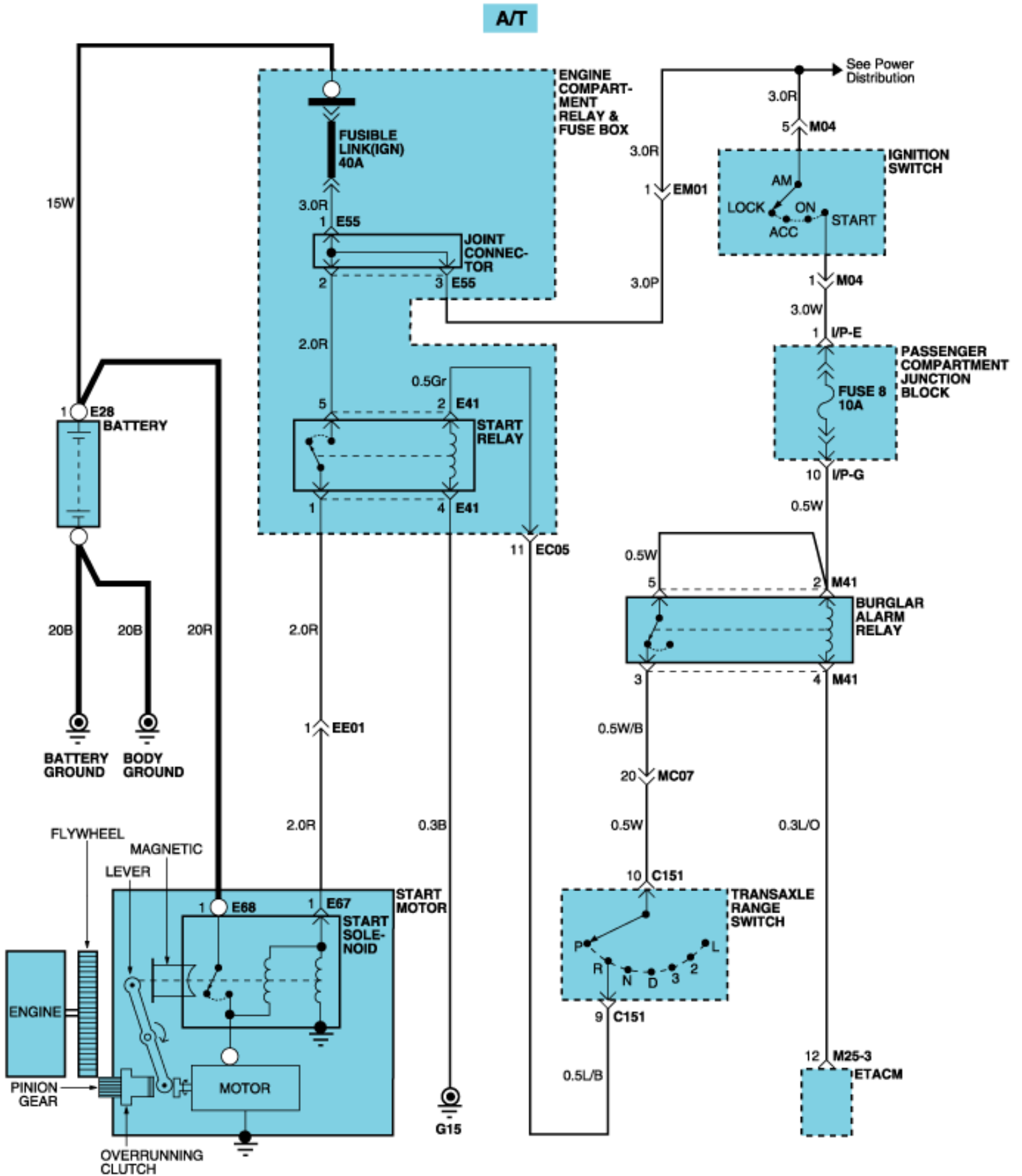

Purchased
from Ebay seller
Reveleus1

Thank-you for purchasing from me, it
is much appreciated.

To contact me please email
suzlever@gmail.com

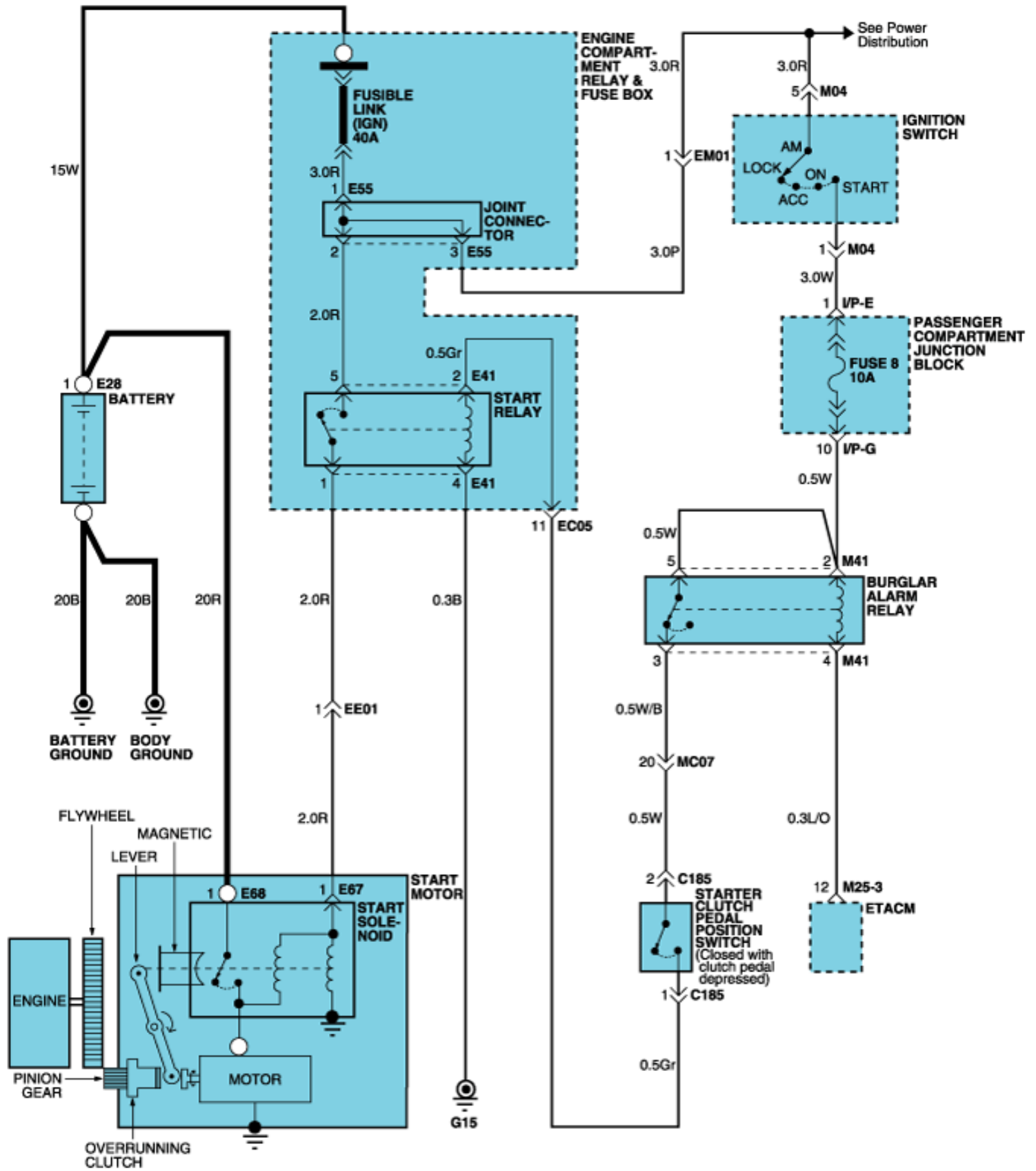



TROUBLESHOOTING

IGNITION SYSTEM

Symptom	Suspect Area	Remedy (See Page)
Engine will not start or is hard to start (Crank OK)	Ignition lock switch Ignition coil Spark plugs Ignition wiring disconnected or broken Spark plug cable	See page EE-20 See page EE-19 See page EE-17 See page EE-21 See page EE-18
Rough idle or stalls	Ignition wiring Ignition coil Spark plug cable	Inspect See page EE-19 See page EE-18
Engine hesitates/poor acceleration	Spark plugs and spark plug cable Ignition wiring	See page EE-18 Inspect
Poor mileage	Spark plugs and spark plug cable	See page EE-18

CHARGING SYSTEM

Symptom	Suspect Area	Remedy (See Page)
Charging warning indicator does not light with ignition switch "ON" and engine off	Fuse blown Light burned out Wiring connection loose Electronic voltage regulator	Check fuses Replace light Tighten loose connections See page EE-26
Charging warning indicator does not go out with engine running (Battery requires frequent recharging)	Drive belt loose or worn Battery cables loose, corroded or worn Fuse blown Fusible link blown Electronic voltage regulator or generator Wiring	See page EE-24, 35 See page EE-32 Check fuses Replace fusible link See page EE-26 Repair wiring
Engine hesitates/poor acceleration Overcharge	Drive belt loose or worn Wiring connection loose or open circuit Fusible link blown Poor grounding Electronic voltage regulator or generator Worn battery Electronic voltage regulator Voltage sensing wire	See page EE-24, 35 Tighten loose connection or repair wiring Replace fusible link Repair See page EE-26 Replace battery See page EE-26 Repair wire

STARTING SYSTEM

Ebay User ID: reveleus1

Symptom	Suspect Area	Remedy (See Page)
Engine will not crank	Battery charge low Battery cables loose, corroded or worn out Transaxle range switch (Vehicle with automatic transaxle only) Fusible link blown Starter motor faulty Ignition switch faulty	Charge or replace battery Repair or replace cables See page TR group-automatic transaxle Replace fusible link See page EE-42 See page EE-20
Engine cranks slowly	Battery charge low Battery cables loose, corroded or worn out Starter motor	Charge or replace battery Repair or replace cables See page EE-42
Starter keeps running	Starter motor Ignition switch	See page EE-42 See page EE-20
Starter spins but engine will not crank	Short in wiring Pinion gear teeth broken or starter motor Ring gear teeth broken	Repair wiring See page EE-44 See page EM group-fly wheel

CRUISE CONTROL SYSTEM

NOTE

Before troubleshooting :

- Check the No.2(10A), No.8(10A), No.10(10A) and No.16(15A) fuse in the under - hood fuse/relay box.
- Check that the horn sounds.
- Check the tachometer to see if it works properly.

Symptom	Suspect Area	See Page
Cruise control cannot be set	Cruise control switch Brake switch A/T gear position switch Cruise control unit	See page EE-50 See page EE-51 See page TR group-automatic transaxle See page EE-7
Cruise control cannot be set and indicator light does not go on	Dimming circuit in gauge Cruise control unit	See page EE-7 See page EE-7
Cruise speed is noticeably higher or lower than what was set	Vehicle speed sensor Cruise control unit and actuator cable deflection Cruise control unit	See page TR group-automatic transaxle See page EE-53 See page EE-7

Excessive overshooting or undershooting when trying to set speed	Cruise control unit and actuator cable deflection Vehicle speed sensor Cruise control unit	See page EE-53 See page TR group-automatic transaxle See page EE-7
Speed fluctuation on a flat road with cruise control set	Vehicle speed sensor Cruise control unit and actuator cable deflection Cruise control unit	See page TR group-automatic transaxle See page EE-53 See page EE-7
Vehicle does not decelerate or accelerate accordingly when SET/RESUME/CANCEL button is pushed	Cruise control switch Cruise control unit	See page EE-50 See page EE-7
Cruise control does not cancel when shift lever is moved to N position (A/T)	A/T gear position switch Cruise control unit	See page TR group-automatic transaxle See page EE-7
Set speed is not cancelled when brake pedal is pushed	Brake switch Cruise control unit	See page EE-51 See page EE-7
Cruise control will not cancel when main switch is pushed OFF	Cruise control switch Cruise control unit	See page EE-50 See page EE-7
Cruise control will not cancel when CANCEL button is pushed	Cruise control switch Cruise control unit	See page EE-50 See page EE-7
Set speed will not resume when RESUME button (with main switch on, when set speed is temporarily cancelled) is depressed	Cruise control switch Cruise control unit	See page EE-50 See page EE-7
The transmission shifts down slower than normal when going up a hill with the cruise control on (A/T)	Troubleshooting the cruise control communication circuit	See page EE-7

CRUISE CONTROL COMMUNICATION CIRCUIT TROUBLESHOOTING (A/T)

1. Start the engine.
2. Turn on the cruise control main switch, then drive the vehicle to speeds over 25 mph (40km/h) with the cruise control.
 - Does the cruise control operate ?
 - Go to step 3.
 - Check the cruise control unit or cruise control actuator.

3. Measure the voltage between the No.4 terminal of the cruise control unit connector and ground.
Ebay User ID: reveleus1

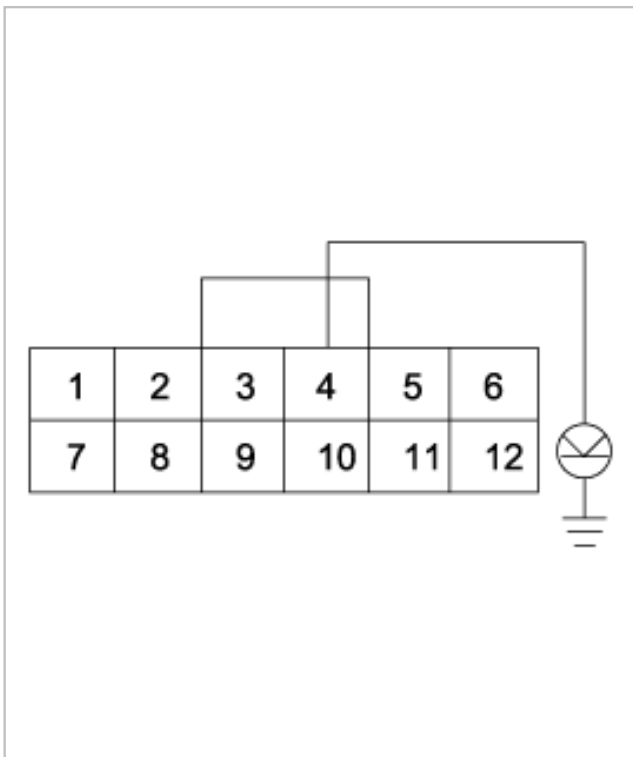

Is there approx. 1V?

- Go to step 4.

- Replace the cruise control unit.

4. Measure the voltage between the No.8 terminal of the TCM connector and ground.

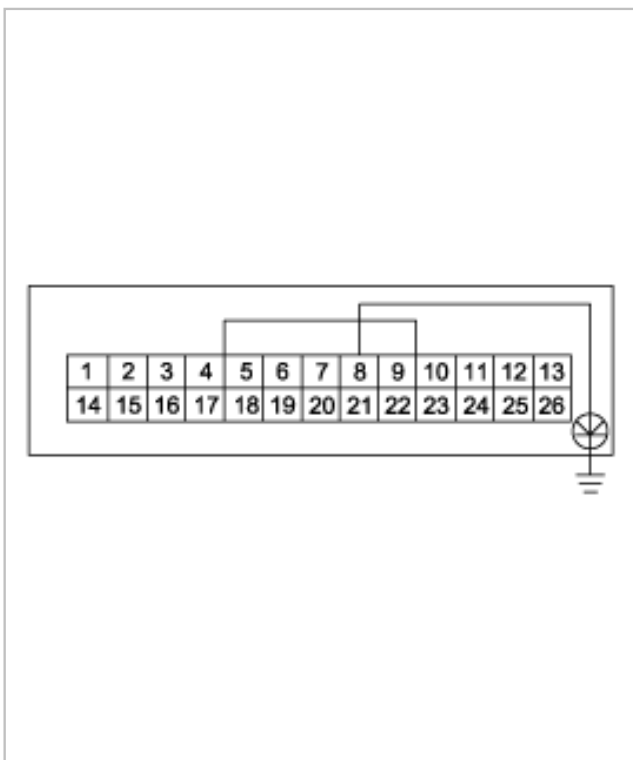

Is there approx. 1V?

- Repair short or open in the wire between the No.8 terminal and cruise control unit.