



HYUNDAI

Elantra



Workshop Manual
2001 - 2006



AIRBAG DISPOSAL

Special Tool Required

Before scrapping any airbags or side airbags (including those in a whole vehicle to be scrapped), the airbags or side airbags must be deployed. If the vehicle is still within the warranty period, before deploying the airbags or side airbags, the Technical Manager must give approval and/or special instruction. Only after the airbags or side airbags have been deployed (as the result of vehicle collision, for example), can they be scrapped. If the airbags or side airbags appear intact (not deployed), treat them with extreme caution.

Deploying Airbags In the vehicle

If an SRS equipped vehicle is to be entirely scrapped, its airbags or side airbags should be deployed while still in the vehicle. The airbags or side airbags should not be considered as salvageable parts and should never be installed in another vehicle.

1. Turn the ignition switch OFF, and disconnect the battery negative cable and wait at least three minutes.
2. Confirm that each airbag or side airbag are securely mounted.
3. Confirm that the special tool is functioning properly by following the check procedure.

Driver's Airbag :

4. Remove the driver's airbag and the install the SST(0957A-38500).
5. Install the driver's airbag on the steering wheel.

Front Passenger's Airbag :

6. Remove the glove box, then disconnect the 4P connector between the front passenger's airbag and SRS main harness.
7. Install the SST(0957A-2D200).

NOTE

When scrapping a car or intentionally deploying the replaced airbag modules (DAB, PAB), deploy individual stage.

Side Airbag :

8. Disconnect the 2P connector between the side airbag and side wire harness.
9. Install the SST(0957A-3F100).
10. Place the deployment tool at least thirty feet (10 meters) away from the airbag.
11. Connect a 12 volt battery to the tool.
12. Push the tool's deployment switch. The airbag should deploy (deployment is both highly audible and visible: a loud noise and rapid inflation of the bag, followed by slow deflection)

13. Dispose of the complete airbag. No part of it can be reused. Place it in a sturdy plastic bag (A), and seal it securely.



Deploying the Airbag Out of the vehicle

If an intact airbag has been removed from a scrapped vehicle, or has been found defective or damage during transit, storage or service, it should be deployed as follows :

1. Confirm that the special is functioning properly by following the check procedure.
2. Position the airbag face up, outdoors on flat ground at least thirty feet (10meters) from any obstacles or people.

Disposal of Damaged Airbag

1. If installed in a vehicle, follow the removal procedure of driver's airbag, front passenger's and side airbag.
2. In all cases, make a short circuit by twisting together the two airbag inflator wires.
3. Package the airbag in exactly the same packing that the new replacement part come in.

Precautions and Procedures

General Precautions

Please read the following precautions carefully before performing the airbag system service. Observe the instructions described in this manual, or the airbags could accidentally deploy and cause damage or injuries.

- Except when performing electrical inspections, always turn the ignition switch OFF and disconnect the negative cable from the battery, and wait at least three minutes before beginning work.

NOTE

The contents in the memory is not erased even if the ignition switch is turned OFF or the battery cables are disconnected from the battery.

- Use the replacement parts which are manufactured to the same standards as the original parts and quality. Do not install used SRS parts from another vehicle. Use only new parts when making SRS repairs.
- Carefully inspect any SRS part before you install it. Do not install any part that shows signs of being dropped or improperly handled, such as dents, cracks or deformation.

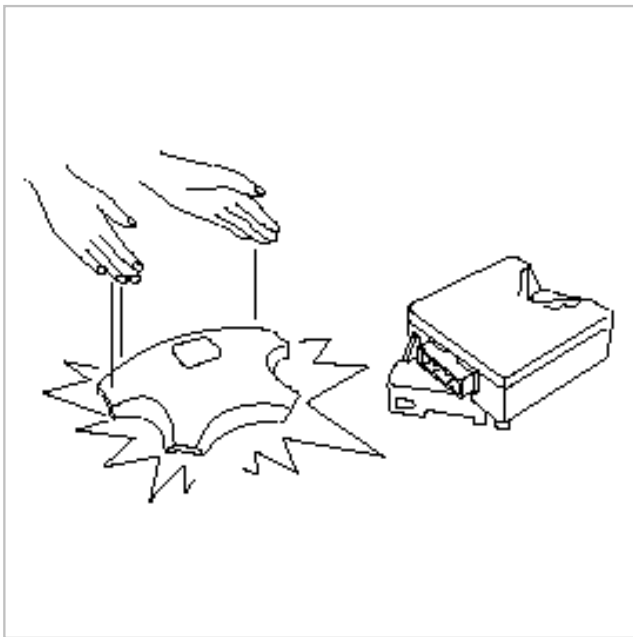

- Before removing any of the SRS parts (including the disconnection of the connectors), always disconnect the SRS connector.
- The original radio has coded theft protection circuit. Be sure to get the customer's radio code before disconnecting the battery cable.

Airbag Handling and Storage

For temporary storage of the air bag during service, please observe the following precautions.

- Store the removed airbag with the pad surface up.

- Keep free from any oil, grease, detergent, or water to prevent damage to the airbag assembly.

ebay User ID: revereus1

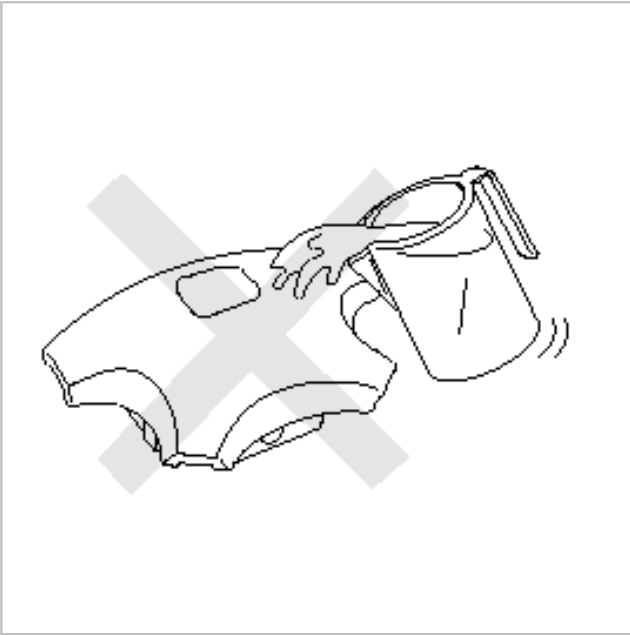

- Store the removed airbag on secure, flat surface away from any high heat source (exceeding 200°F/93°C).
- Never perform electrical inspections to the airbags, such as measuring resistance.
- Do not position yourself in front of the airbag assembly during removal, inspection, or replacement.
- Refer to the scrapping procedures for disposal of the damaged airbag.
- Be careful not to bump or impact the SRS unit or the side impact sensors whenever the ignition switch is ON, or at wait least for three minutes after the ignition switch is turned OFF before begin work.
- During installation or replacement, be careful not to bump (by impact wrench, hammer, etc.) the area around the SRS unit and the side impact sensor. The airbags could accidentally deploy and cause damage or injury.
- After a collision in which the airbags were deployed, replace the front airbags and the SRS unit. After a collision in which the side airbag was deployed, replace the side air bag and side impact sensor on the side where the side airbag deployed and the SRS unit. After a collision in which the airbags or the side air bags did not deploy, inspect for any damage or any deformation on the SRS unit and the side impact sensors. If there is any damage, replace the SRS unit and/or the side impact sensors.
- Do not disassemble the SRS unit or the side impact sensors.
- Turn the ignition switch OFF, disconnect the battery negative cable and wait at least three minutes before beginning installation or replacement of the SRS unit.
- Be sure the SRS unit and side impact sensors are installed securely with the mounting bolts.
- Do not spill water or oil on the SRS unit or the side impact sensors and keep them away from dust.
- Store the SRS unit and the side impact sensors in a cool (less than 104°F/40°C) and dry (less than 80% relative humidity, no moisture) area.

Wiring Precautions

SRS wiring can be identified by special yellow outer covering (except the SRS circuits under the front seats). Observe the instructions described in this section.

- Never attempt to modify, splice, or repair SRS wiring.
If there is an open or damage in SRS wiring, replace the harness.

Ebay User ID: reveleus1

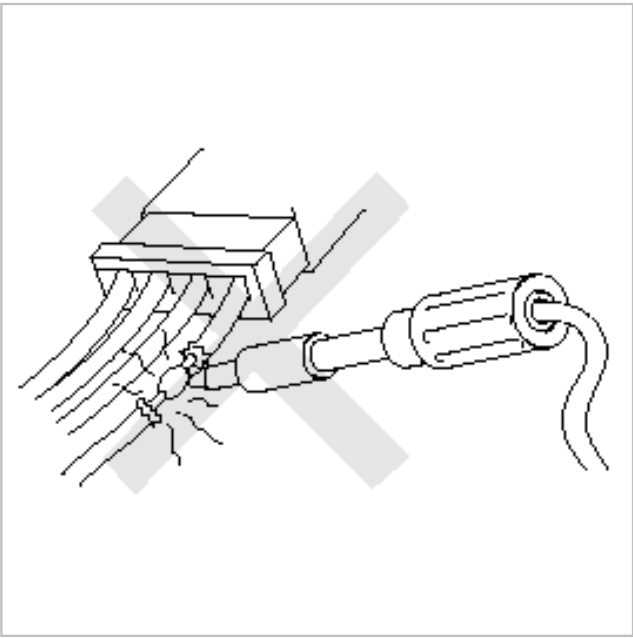

- Be sure to install the harness wires so that they are not pinched, or interfere with other parts.

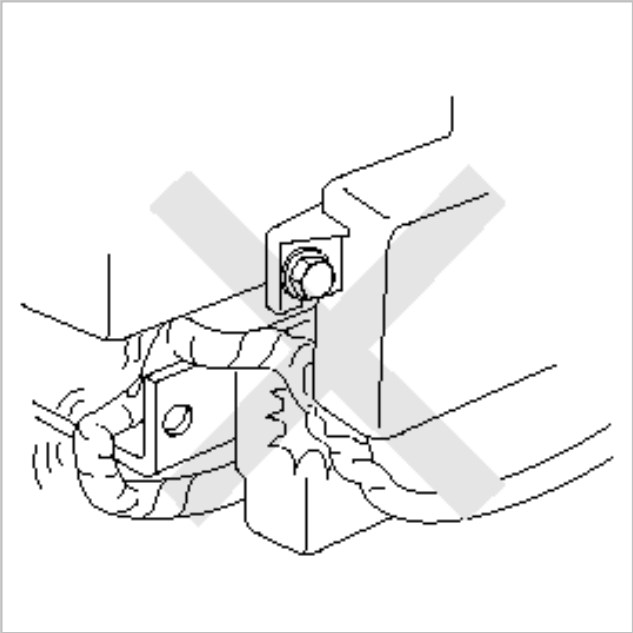

- Make sure all SRS ground locations are clean, and grounds are securely fastened for optimum metal-to-metal contact. Poor grounding can cause intermittent problems that are difficult to diagnose.

Precautions for Electrical Inspections.

- When using electrical test equipment, insert the probe of the tester into the wire side of the connector. Do not insert the probe of the tester into the terminal side of the connector, and do not tamper with the connector.

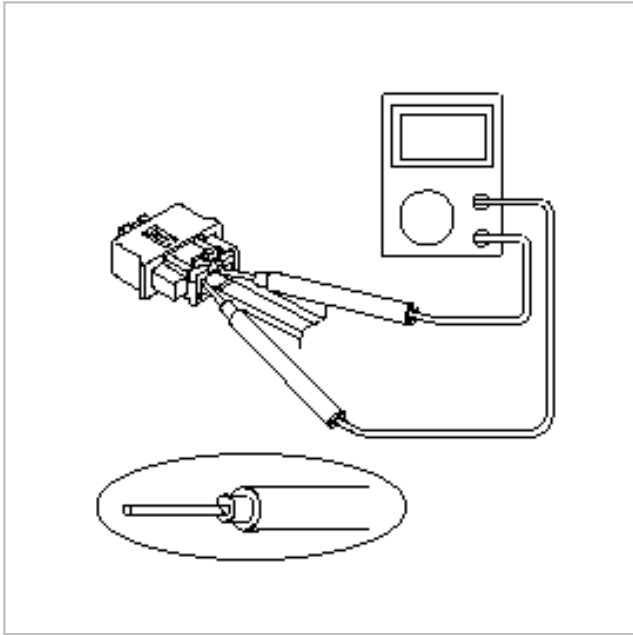

- Use a u-shaped probe. Do not insert the probe forcibly.
 - Use specified service connectors for troubleshooting.
- Using improper tools could cause an error in inspection due to poor metal contact.

Spring-loaded Lock Connector Airbag Connector

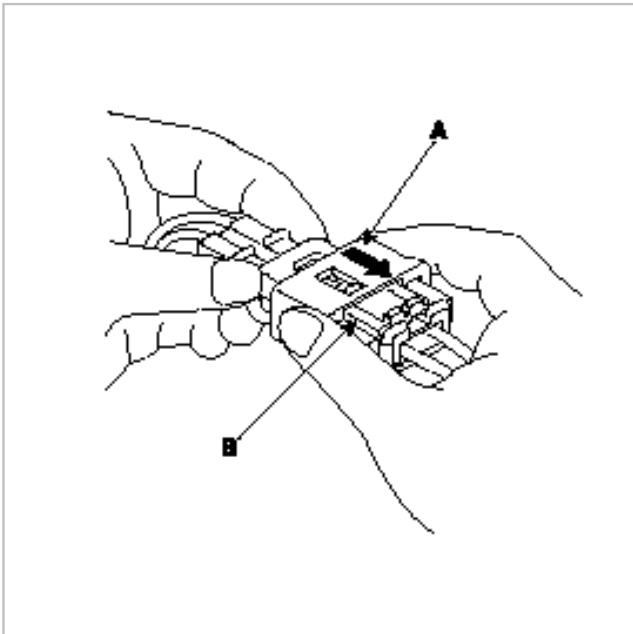

Connecting

1. To reconnect, hold the pawl-side connector half, and press on the back of the sleeve-side connector half in the direction shown. As the two connector halves are pressed together, the sleeve (A) is pushed back by the pawl (C). Do not touch the sleeve.

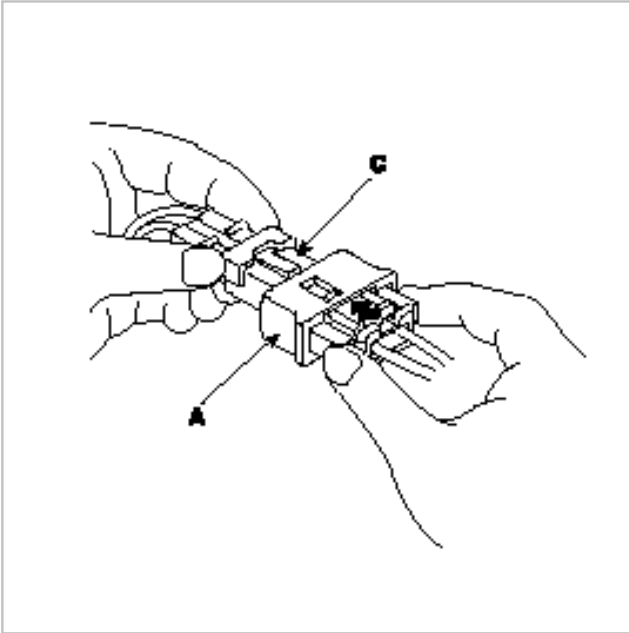

2. When the connector halves are completely connected, the pawl is released, and the spring-loaded sleeve locks the connector.

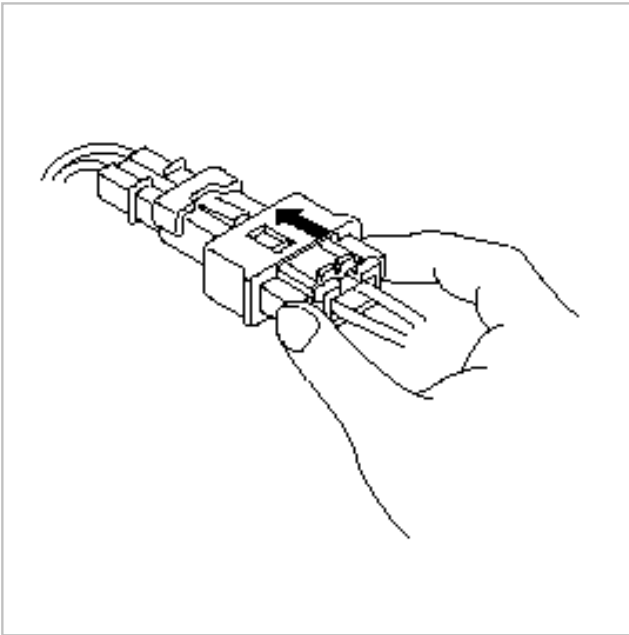



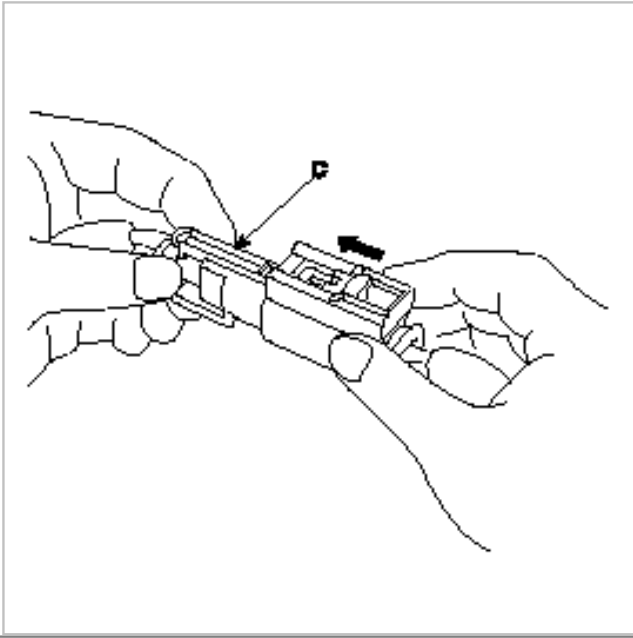
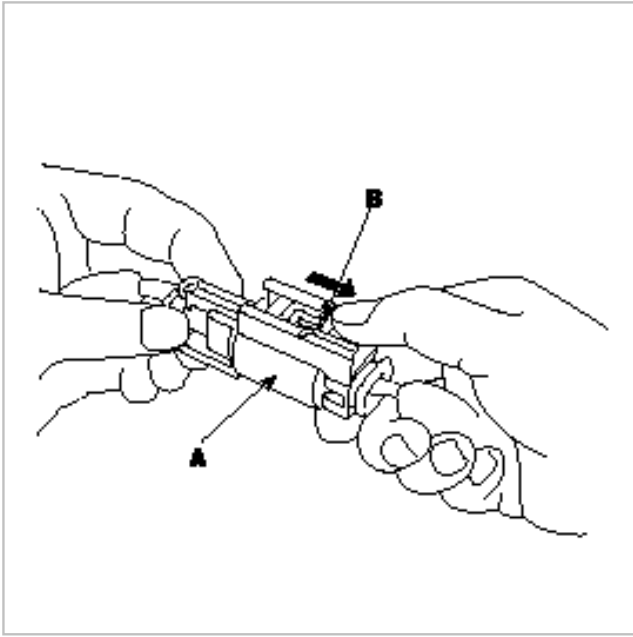

Airbag Connector



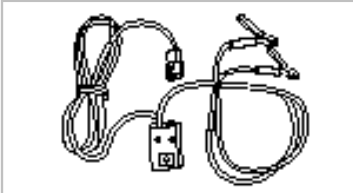
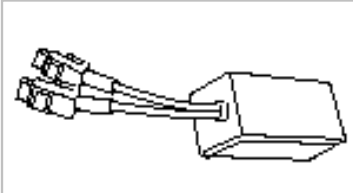

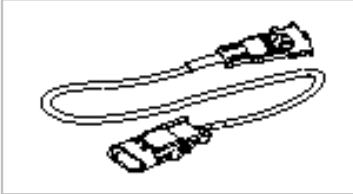
SPECIAL TOOLS

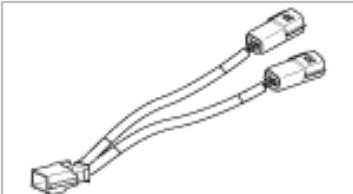
Tool (Number and name)	Illustration	Use
0957A-34100A Deployment tool		Airbag deployment tool PAB : 0957A-38100 DAB, BPT : 0957A-2D200 SAB : 0957A-3F100
0957A-38200 Dummy		Simulator to check the resistance of each wiring harness Dummy adapter PAB : 0957A-2D100 DAB, BPT : 0957A-1C000 SAB : 0957A-3F000
0957A-2D200 Deployment adapter		Use with deployment tool.
0957A-38500 Deployment adapter		Use with deployment tool.
0957A-3F100 Deployment adapter		Use with deployment tool.
0957A-2D100 Dummy adapter		Use with dummy.

0957A-1C000
Dummy adapter

Ebay User ID: reveleus1

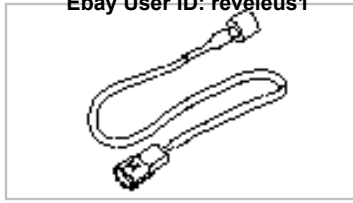

Use with dummy.

0957A-3F000
Dummy adapter



Use with dummy.

- * DAB :Driver Airbag
- * PAB : Prassenger Airbag
- * SAB : Side Airbag
- * BPT : Belt Pretensioner

COMPONENT

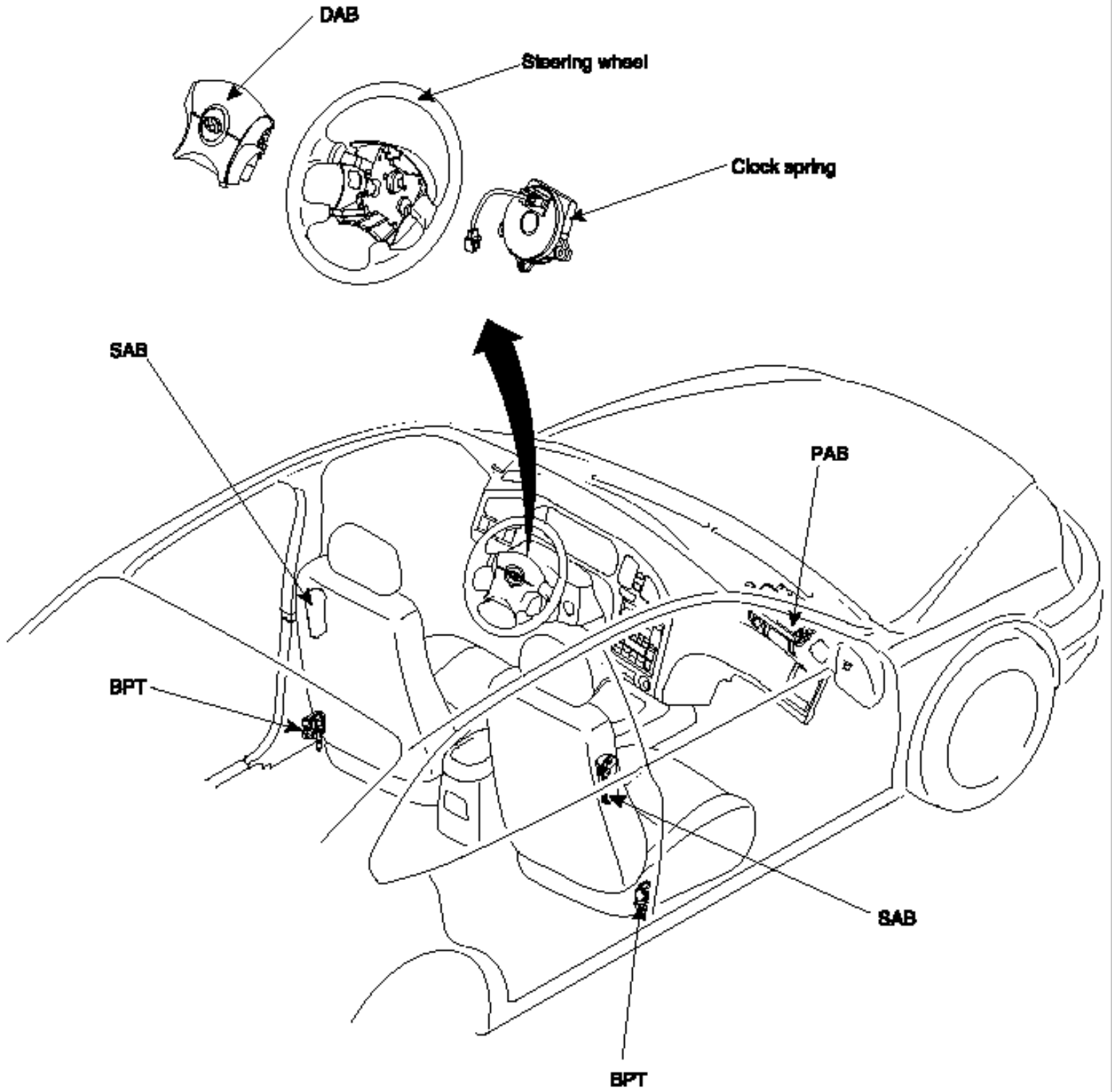

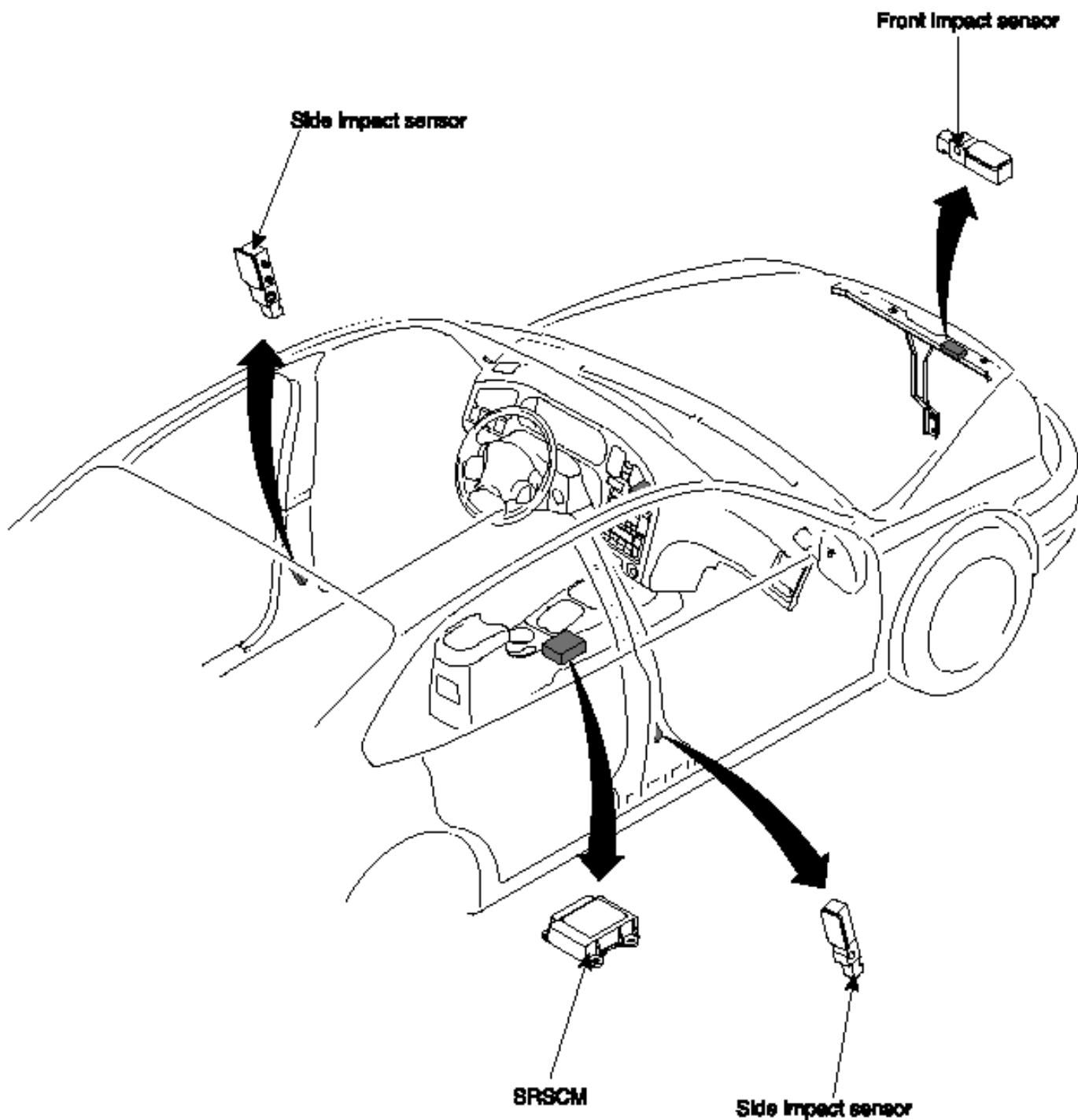

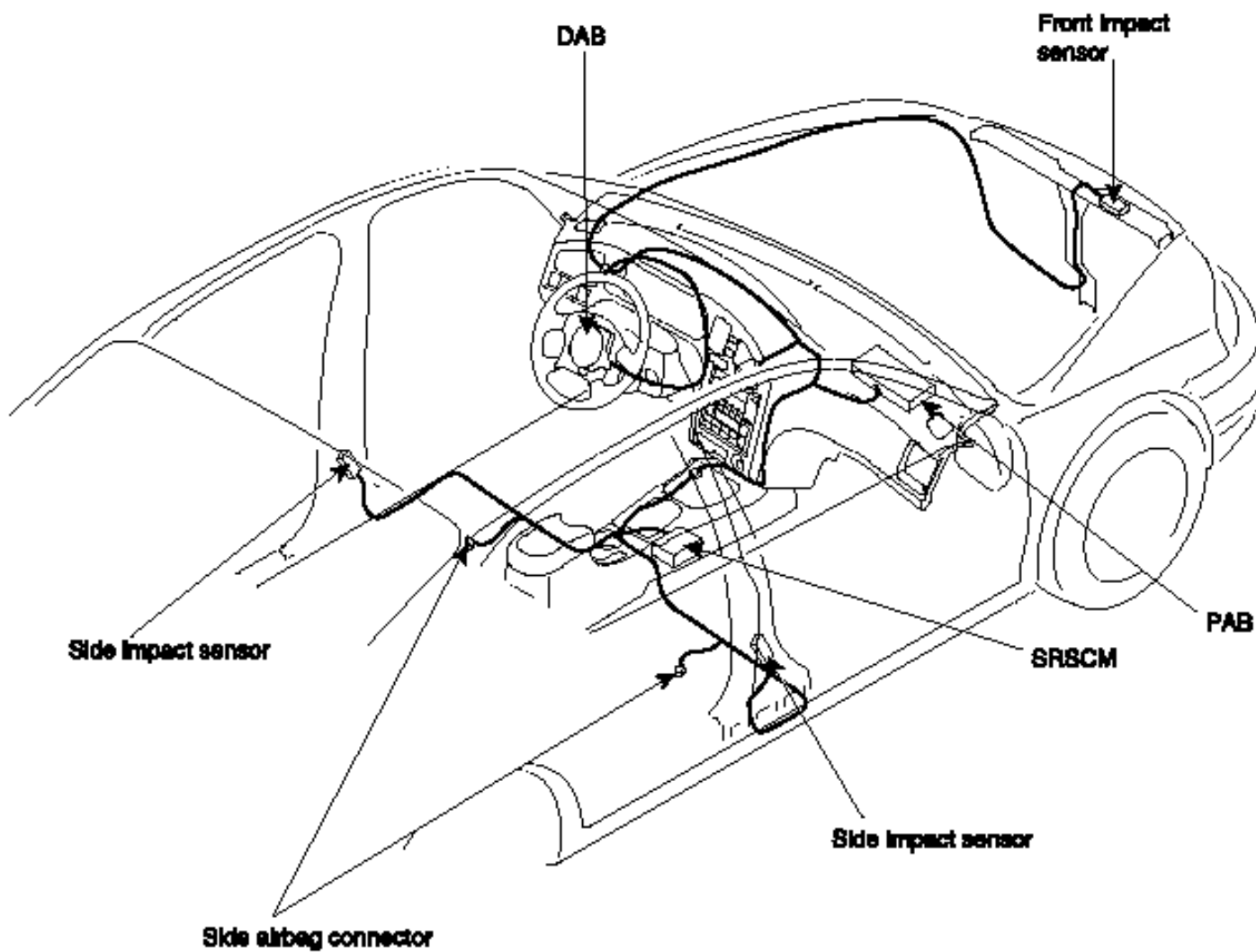

Purchased
from Ebay seller
Reveleus1

Thank-you for purchasing from me, it
is much appreciated.

To contact me please email
suzlever@gmail.com

SRSCM

The primary purpose of the advanced restraint control module is to discriminate between an event that warrants restraint system deployment and an event that does not. The advanced restraint control module must decide if and when to deploy the restraint system pretensioners and airbags. After determining that pretensioners and/or airbag deployment is required, the advanced restraint control module must supply sufficient power to the pretensioners and airbag igniters to initiate deployment. The advanced restraint control module determines that an impact may require deployment of the pretensioners and airbags from data obtained from buckle switches, seat track position sensors, occupant classification system, front impact sensors and side impact sensors in conjunction with a safing function.

The advanced restraint control module will not be ready to detect a crash or to activate the restraint system devices until the signals in the advanced restraint control module circuitry stabilize. It is possible that the advanced restraint control module could activate the safety restraint devices in approximately 2 seconds but is guaranteed to fully function after prove-out is completed.

The advanced restraint control module must perform a diagnostic routine and light a system readiness indicator at key-on. The system must perform a continuous diagnostic routine and provide fault annunciation through a warning lamp indicator in the event of fault detection.

A serial diagnostic communication interface will be used to facilitate servicing of the advanced restraint control system.

FRONT AIRBAGS

The Driver and front passenger airbags are two stage devices. If the crash algorithm determines that only the first stage is to be activated, the second stage will be automatically disposed of after a programmable time in 120 milliseconds has elapsed since the first stage deployment. The driver and front passenger firing loops (4 total) are backed up (Back-up Power Supply) for 150ms if the battery connection is lost in a crash.

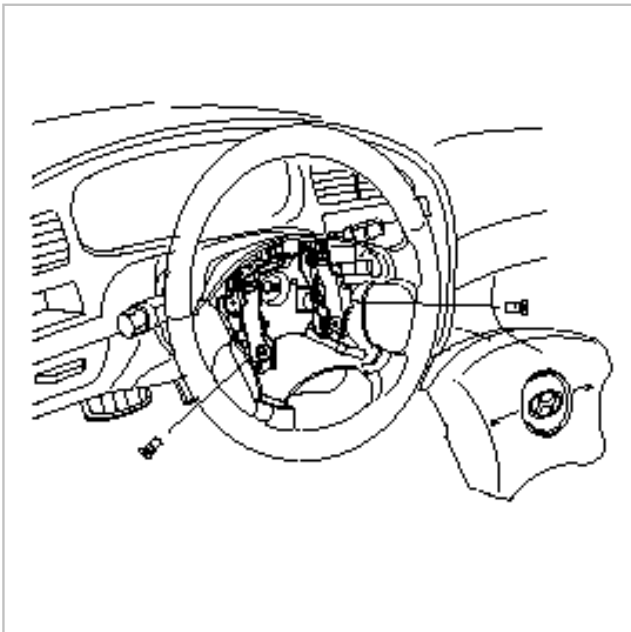

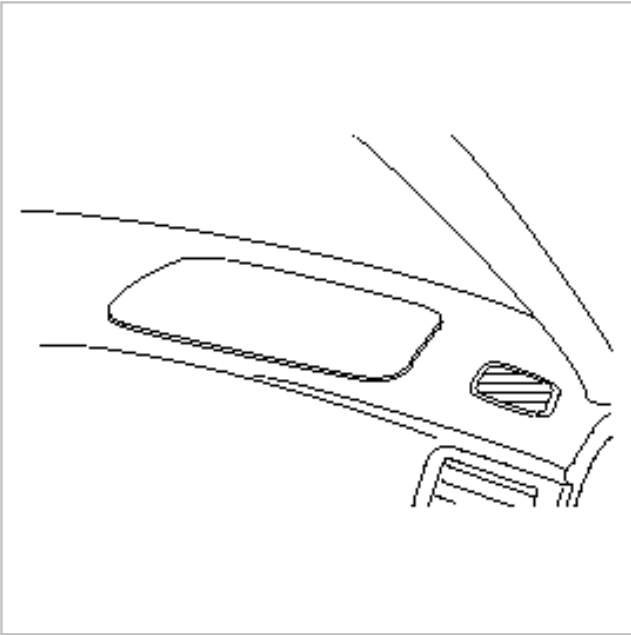

OC (OCCUPANT CLASSIFICATION) SYSTEM

In contrast to the initial one-stage airbag systems, newer restraint systems involve complex logic to select, or alternatively suppress, various levels of safety system deployment.

Inherent to an Advanced Restraint System is the ability to discern information regarding passenger occupancy. It is intended that these inputs be provided through the OCS. The objective of such safety system is to reduce the risk and level of injuries by automatically adapting the airbag(s) and seat belt pretensioner to the driving status of the vehicle, its occupants, and the crash severity.

The current OCS covered in this specification continually senses and classifies the front passenger side seat.

SIDE IMPACT SENSOR

The Side Impact Sensors are remote sensor that detect acceleration due to collision at their mounting locations. The primary purpose of the Side Impact Sensors is to provide an indication of a collision earlier than is possible from a central mounting location. The Side Impact Sensors send acceleration data to the central control module.



FRONT IMPACT SENSOR

The Front Impact Sensor is a remote sensor that provides accelerometer data to the advanced restraint control module to determine if the severity of a frontal impact event warrants a single-stage or dual-stage frontal airbag deployment.

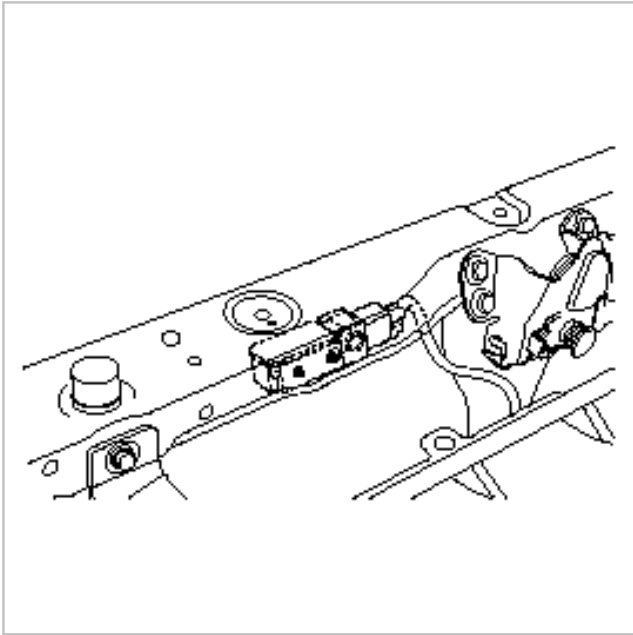

Backup power

The advanced restraint control module must provide deployment power to the Front Impact Sensor for a minimum of 150 ms after loss of vehicle power.

STPS (SEAT TRACK POSITION SENSOR)

The STPS operated via a non-contacting magnetic proximity sensing device combined with a simple electronic circuit resulting in the ability of producing two separate & distinct logic level signals.

The STPS output signal is altered by the proximity of a separate ferro-magnetic shunt, which is linked via the seat track. The logic signal produced is the result of the proximity device being activated (no shunt present) or deactivated (shunt present).

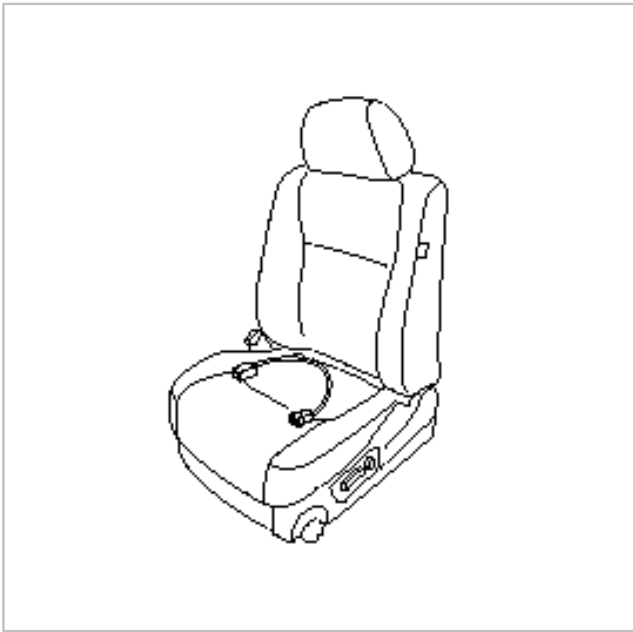

Driver's Airbag Replacement

1. Disconnect the battery negative cable and wait at least three minutes before beginning work.
2. Remove the two Torx bolts (A), then remove the driver's airbag (B).

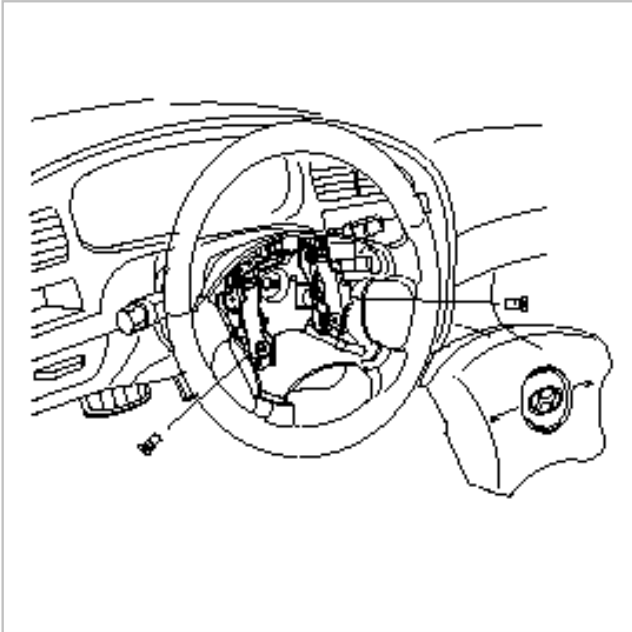

3. Remove the driver's airbag from the steering wheel, then disconnect the driver's airbag 2P connectors.

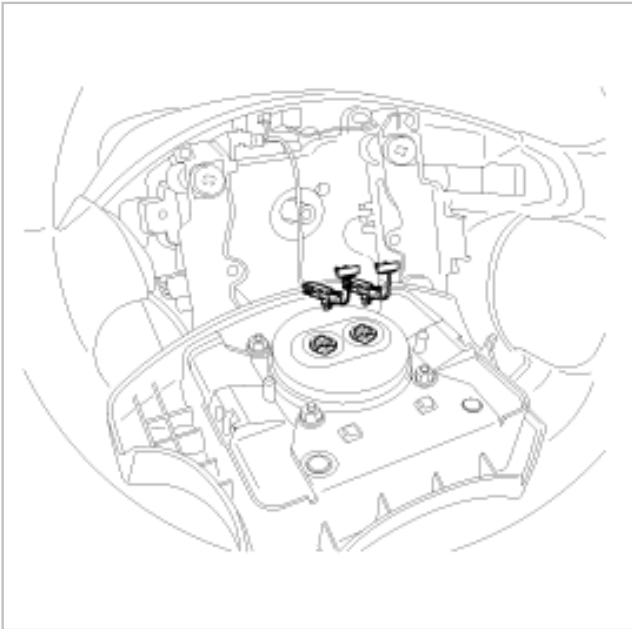

INSTALLATION

1. Connect the driver's airbag 2P connectors, then install the driver's airbag on the steering wheel.
2. Secure the airbag with the new Torx bolts.
3. Connect the battery negative cable.
4. After installing the airbag, confirm proper system operation :
 - A. Turn the ignition switch ON; the SRS indicator light should blink for about six seconds and then go off.
 - B. Make sure both horn buttons work.

PASSENGER AIRBAG REPLACEMENT

REMOVAL

1. Disconnect the battery negative cable and wait at least three minutes before beginning work.
2. Remove the glove box (see BD group - glove box) , then disconnect the connector between the SRS main harness 4P connector (A) and front passenger's airbag 4P connector (B).

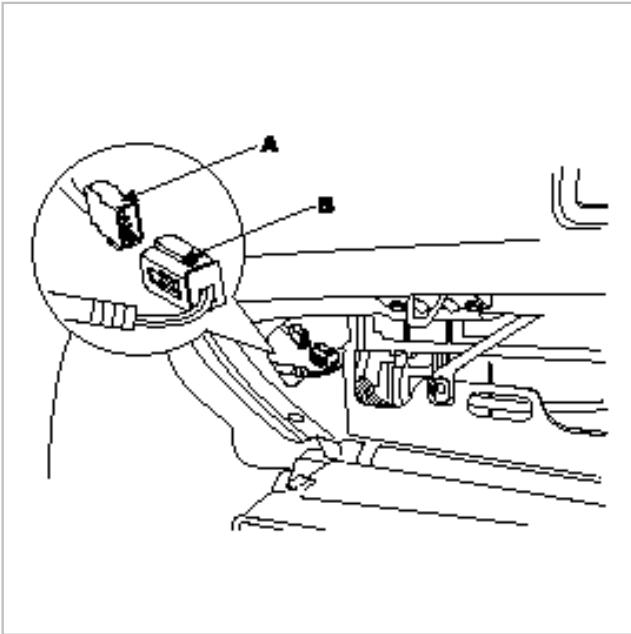

3. Remove the dashboard. (see BD group - dashboard)
4. Remove the mounting nuts (A) from the dashboard. Then remove the passenger's airbag.

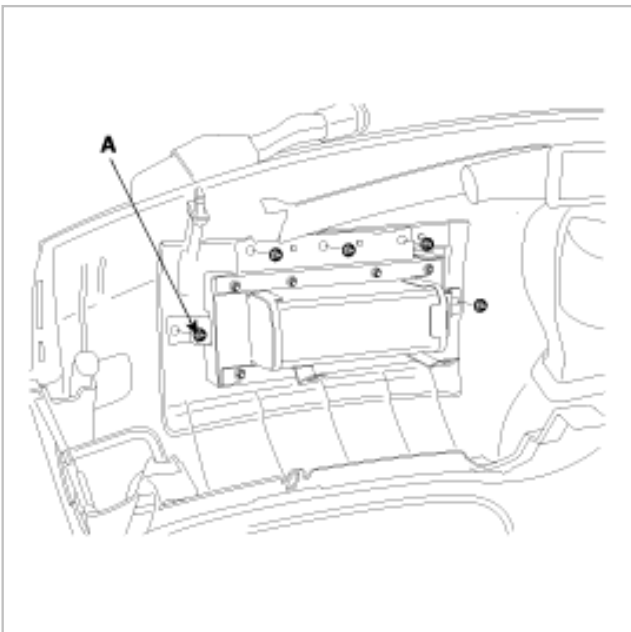

INSTALLATION

1. Place the new front passenger's airbag on the dashboard. Tighten the front passenger's airbag mounting nuts.
2. Install the dashboard.
3. Connect the front passenger's airbag 4P connector to the SRS main harness 4P connector.
Attach the front passenger's airbag connector to the connector holder, then reinstall the glove box.

4. Reconnect the battery negative cable.
5. After installing the airbag, confirm proper system operation : Turn the ignition switch On; the SRS indicator light should blink for about six seconds and then go off.
6. Enter the customer's preset radio stations.

SIDE AIRBAG REPLACEMENT

NOTE

Review the seats replacement procedure in the body section of this manual before performing repair ir service.

REMOVAL

1. Disconnect the battery negative cable and wait at least three minutes before beginning work.
2. Disconnect the side airbag harness 2P connector (A).

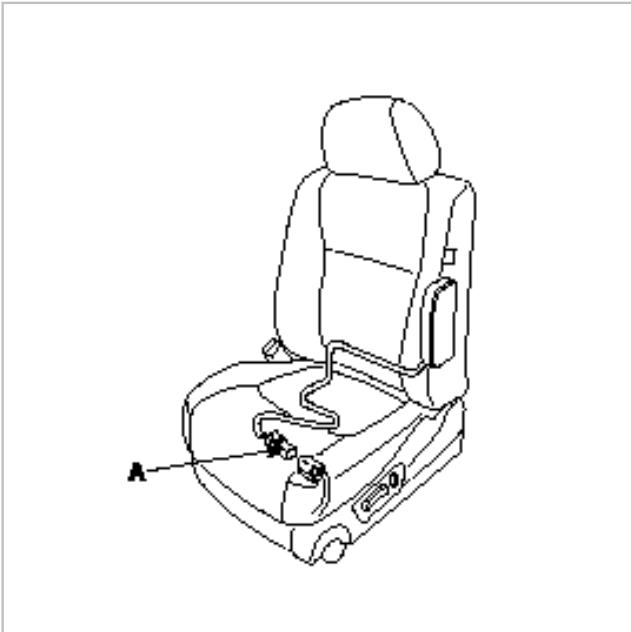

3. Remove the seat assembly and seat-back cover.
4. Remove the two mounting nuts (A) and the side airbag (B).

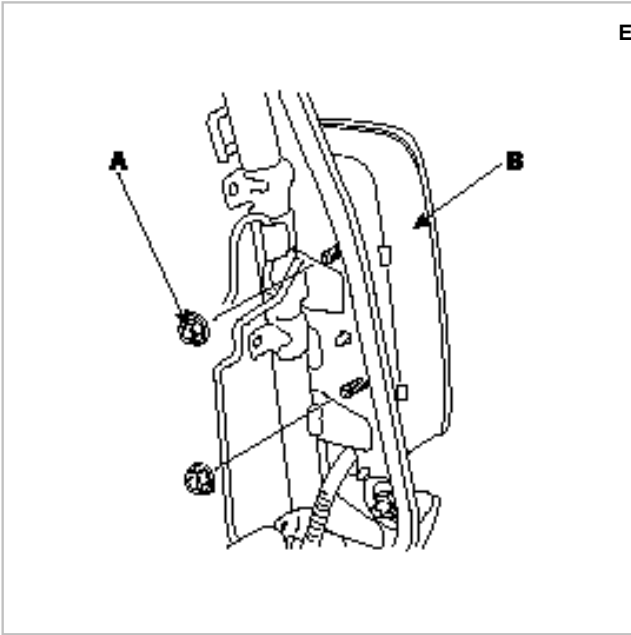

INSTALLATION

CAUTION

Be sure to install the harness wires so that they are not pinched or interfering with other parts.

NOTE

- If the side airbag lid is affixed by a tape, remove the tape.
- Do not open the lid of the side airbag cover.
- Use new mounting nuts tightened to the specified torque when you replace a side airbag.
- Make sure that the seat-back cover is installed properly. Improper installation may prevent the proper deployment.

1. Place the new side airbag on the seat back-frame. Tighten the side airbag mounting nuts.
2. Install the new seat-back cover.
3. Install the seat assembly, then connect the side airbag harness 2P connector.
4. Reconnect the battery negative cable.
5. After installing the side airbag, confirm proper system operation: Turn the ignition switch ON; the SRS indicator light should blink for about six seconds and then go off.
6. Recline and slide the front seat forward fully, make sure the harness wires are not pinched or interfering with other parts.

SEAT TRACK POSITION SENSOR REPLACEMENT

REMOVAL

1. Disconnect the battery negative cable and wait at least three minutes before beginning work.
2. Remove the seat assembly.

3. Disconnect the seat track position sensor 2P connector (A).

Ebay User ID: reVeus1



4. Remove the seat track position sensor (A).

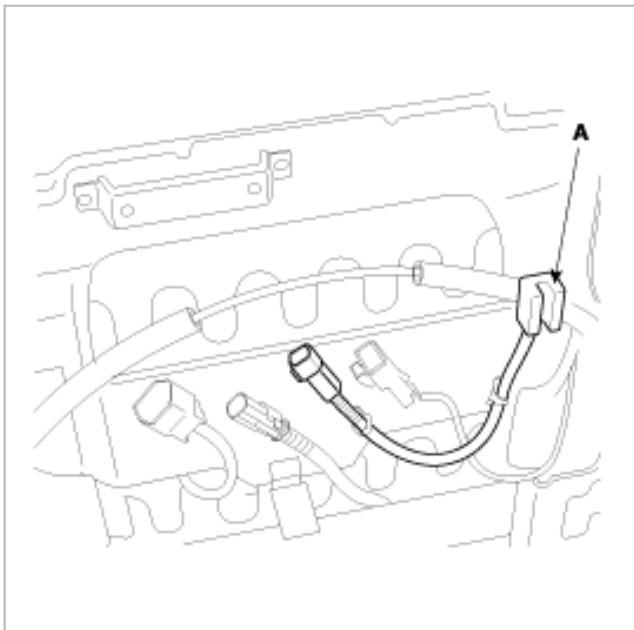

INSTALLATION

CAUTION

Be sure to install the harness wires so that they are not pinched or interfere with other parts.

1. Install the new seat track position sensor.
2. Connect the seat track position sensor 2P connector.
3. Install the seat assembly.
4. Reconnect the battery negative cable.
5. After installing the seat track position sensor, confirm proper system operation: Turn the ignition switch ON; the SRS indicator light should blink for about six seconds and then go off.
6. Recline and slide the front seat forward fully, make sure the harness wires are not pinched or interfering with other parts.

SRS Unit Replacement

Ebay User ID: reveleus1

REMOVAL

1. Disconnect the battery negative cable, and wait at least three minutes before beginning work.
2. Disconnect the airbag connectors.
3. Disconnect the side airbag connectors.
4. Remove the center console. (see BD group - interior)
5. Disconnect the connectors (A) from the SRS unit (B).

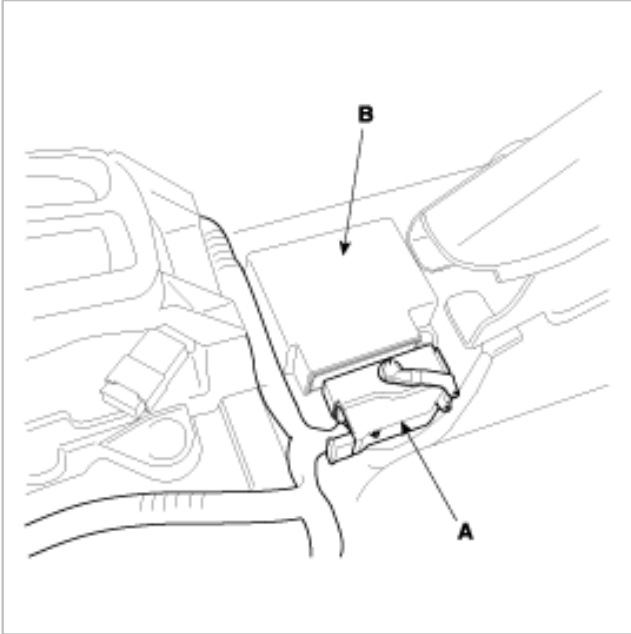

6. Remove the three bolts (A) from the SRS unit (B), then pull out the SRS unit from the bracket.

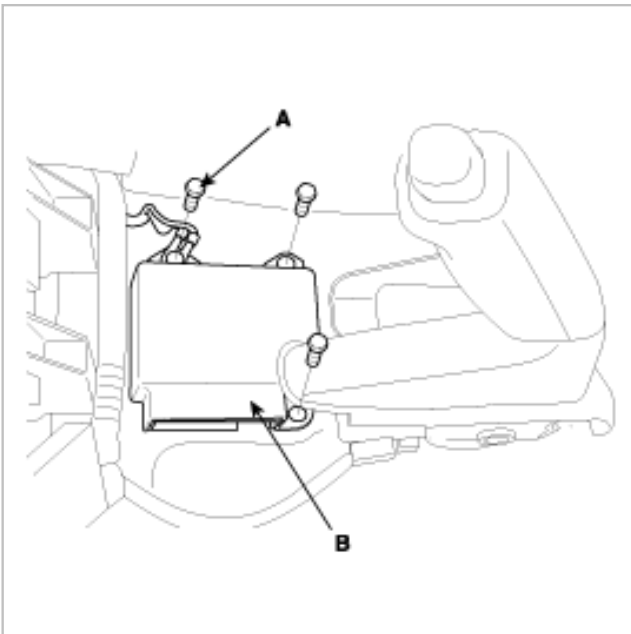

Installation

1. Install the new SRS unit with the three bolts, then connect the connectors to the SRS unit.
2. Install the center console.
3. Reconnect the airbag connectors.
4. Reconnect the side airbag connectors.

5. Reconnect the battery negative cable.

Ebay User ID: reveleus1

6. After installing the SRS unit, confirm proper system operation: Turn the ignition switch ON; the SRS indicator light should blink for about six seconds and then go off.

Belt pretensioner replacement

REMOVAL

1. Disconnect the battery negative cable, and wait at least three minutes before beginning work.
2. Remove the seat assembly (see BD group - seat)
3. Remove the front door scuff trim (see BD group - interior)
4. Remove the center pillar trim (see BD group - interior)
5. Remove the lower anchor bolt (see BD group - belt)
6. Remove the upper anchor bolt (see BD group - belt)
7. Remove the belt pretensioner fixing bolt.

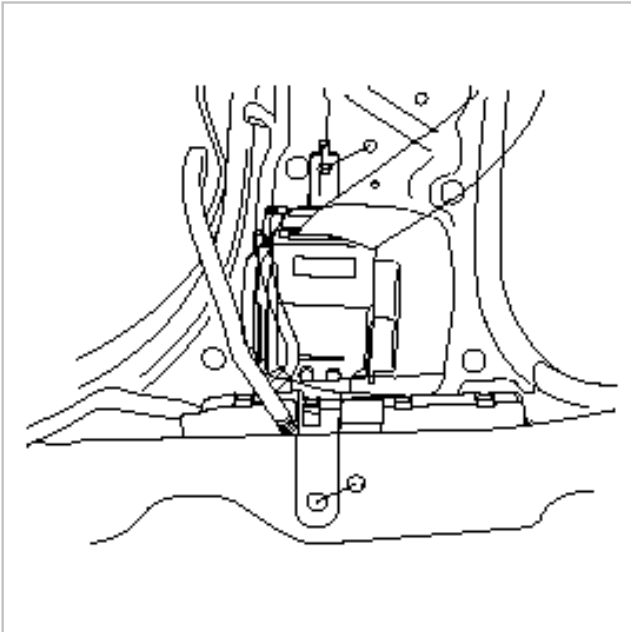

8. Disconnect the belt pretensioner connector (A).

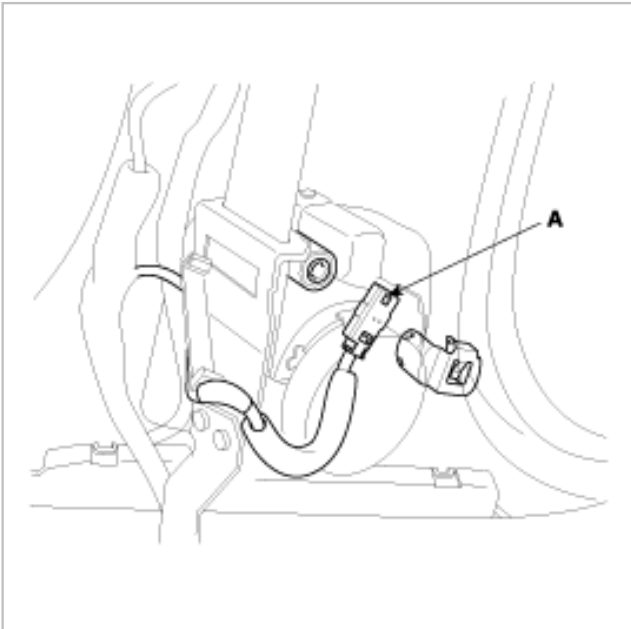

Installation

Ebay User ID: reveleus1

1. Install the new belt pretension with bolt.
2. Install the upper anchor bolt.
3. Install the lower anchor bolt.
4. Install the center pillar trim.
5. Install the front door scuff trim.
6. Install the seat assembly.
7. Reconnect the negative battery cable.
8. After installing the belt pretensioner, confirm proper system operation : Turn the ignition switch ON: the SRS indicator light should blink for about six seconds and then go off.

Side Impact Sensor Replacement

REMOVAL

CAUTION

- Removal of the airbag must be performed according to the precautions/procedures described previously.
- Before disconnecting the side impact sensor 2P connector(s), disconnect the side airbag 2P connector(s).
- Do not turn the ignition switch ON and do not connect the battery cable while replacing the side impact sensor.

1. Disconnect the negative battery cable, and wait at least three minutes before beginning work.
2. Remove the seat assembly (see BD group - seat).
3. Remove the front door sill trim (see BD group - interior).
4. Remove the center pillar trim (see BD group - interior).
5. Remove the lower anchor bolt (see BD group - belt).
6. Remove the belt pretensioner.
7. Disconnect the SRS harness 2P connector from the side impact sensor.
8. Remove the two bolts then remove the side impact sensor (A).



Installation

- Be sure to install the harness wires so that they are not pinched or interfere with other parts.
- Do not turn the ignition switch ON and do not connect the battery cable while replacing the side impact sensor.

1. Install the new side impact sensor with the two bolts then connect the SRS harness 2P connector to the side impact sensor.
2. Reinstall belt pretensioner.
3. Reconnect the negative battery cable.
4. After installing the side impact sensor, confirm proper system operation: Turn the ignition switch ON: the SRS indicator light should blink for about six seconds and then go off.

FRONT IMPACT SENSOR REPLACEMENT

REMOVAL

CAUTION

- Removal of the airbag must be performed according to the precautions/ procedures described previously.
- Before disconnecting the front impact sensor 2P connector, disconnect the front airbag 4P connector(s).
- Do not turn the ignition switch ON and do not connect the battery cable while replacing the front impact sensor.

1. Disconnect the negative battery cable, and wait at least three minutes before beginning work.
2. Remove the radiator guard (see BD group-exterior).
3. Remove the bolt then remove the front impact sensor.
4. Disconnect the SRS harness 2P connector (A) from the front impact sensor (B).

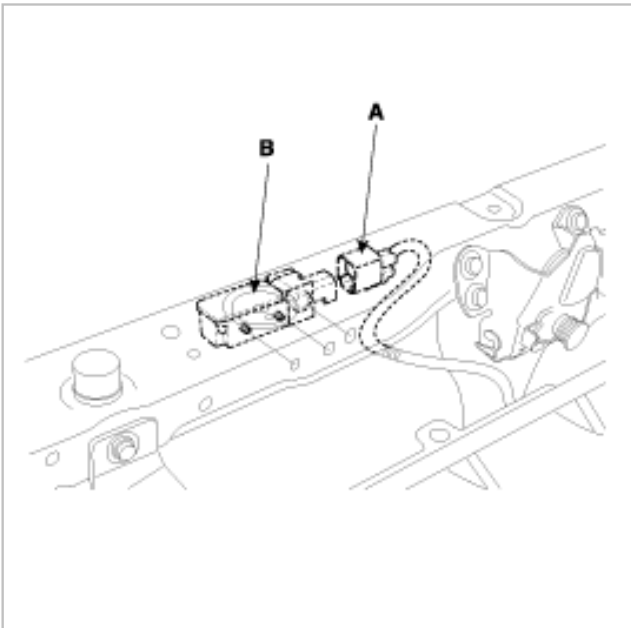

INSTALLATION

CAUTION

Ebay User ID: reveleus1

- Be sure to install the harness wire so that they are not pinched or interfere with other parts.
- Do not turn the ignition switch ON and do not contact the battery cable while replacing the front impact sensor.

1. Install the new front impact sensor with bolt then connect the SRS harness 2P connector to the front impact sensor.
2. Install the radiator guard.
3. Reconnect the negative battery cable.
4. After installing the front impact sensor, confirm proper system operation : Turn the ignition switch ON: the SRS indicator light should blink for about six seconds and then go off.



SRSCM CONNECTOR

DAB+PAB+SAB+BPT

25	24	23	22	21	20	19	18	17	16	15	14	13	12	11	10	9	8	7	6	5	4	3	2	1

50	49	48	47	46	45	44	43	42	41	40	39	38	37	36	35	34	33	32	31	30	29	28	27	26
●	●	●	●	●	●	●	●	●	●	●	●	●	●	●	●	●								

75	74	73	72	71	70	69	68	67	66	65	64	63	62	61	60	59	58	57	56	55	54	53	52	51
●	●	●	●		●	●	●	●	●									●	●	●	●	●	●	

PIN NO.	FUNCTION	INPUT/OUTPUT
1	Not used	-
2 ~ 25	Shorting bar	-
26 ~ 32	Not used	-
33	Passenger side airbag, Low	Output
34	Passenger side airbag, High	Output
35	Driver side airbag, Low	Output
36	Driver side airbag, High	Output
37	Passenger belt pretensioner, Low	Output
38	Passenger belt pretensioner, High	Output
39	Driver belt pretensioner, Low	Output
40	Driver belt pretensioner, High	Output
41	Passenger airbag 2nd, Low	Output
42	Passenger airbag 2nd, High	Output
43	Driver airbag 2nd, Low	Output
44	Driver airbag 2nd, High	Output
45	Passenger airbag 1st, Low	Output
46	Passenger airbag 1st, High	Output
47	Driver airbag 1st, Low	Output
48	Driver airbag 1st, High	Output

49	Warning lamp	Ebay User ID: reveleus1	Output
50	Ground		Input
51	Not used		-
52	Passenger side impact sensor, Low		Input
53	Passenger side impact sensor, High		Input
54	Driver side impact sensor, Low		Input
55	Driver side impact sensor, High		Input
56	Front impact sensor, Low		Input
57	Front impact sensor, High		Input
58 ~ 65	Not used		-
66	Passenger seat track position sensor		Input
67	Driver seat track position sensor		Input
68	Passenger seat buckle switch		Input
69	Driver seat buckle switch		Input
70	Occupant classification		Input
71	Not used		-
72	Crash output		Output
73	K-diagnostic line		Input/output
74	Not used		-
75	Battery supply		Input

DIAGNOSTIC TROUBLESHOOTING FLOW

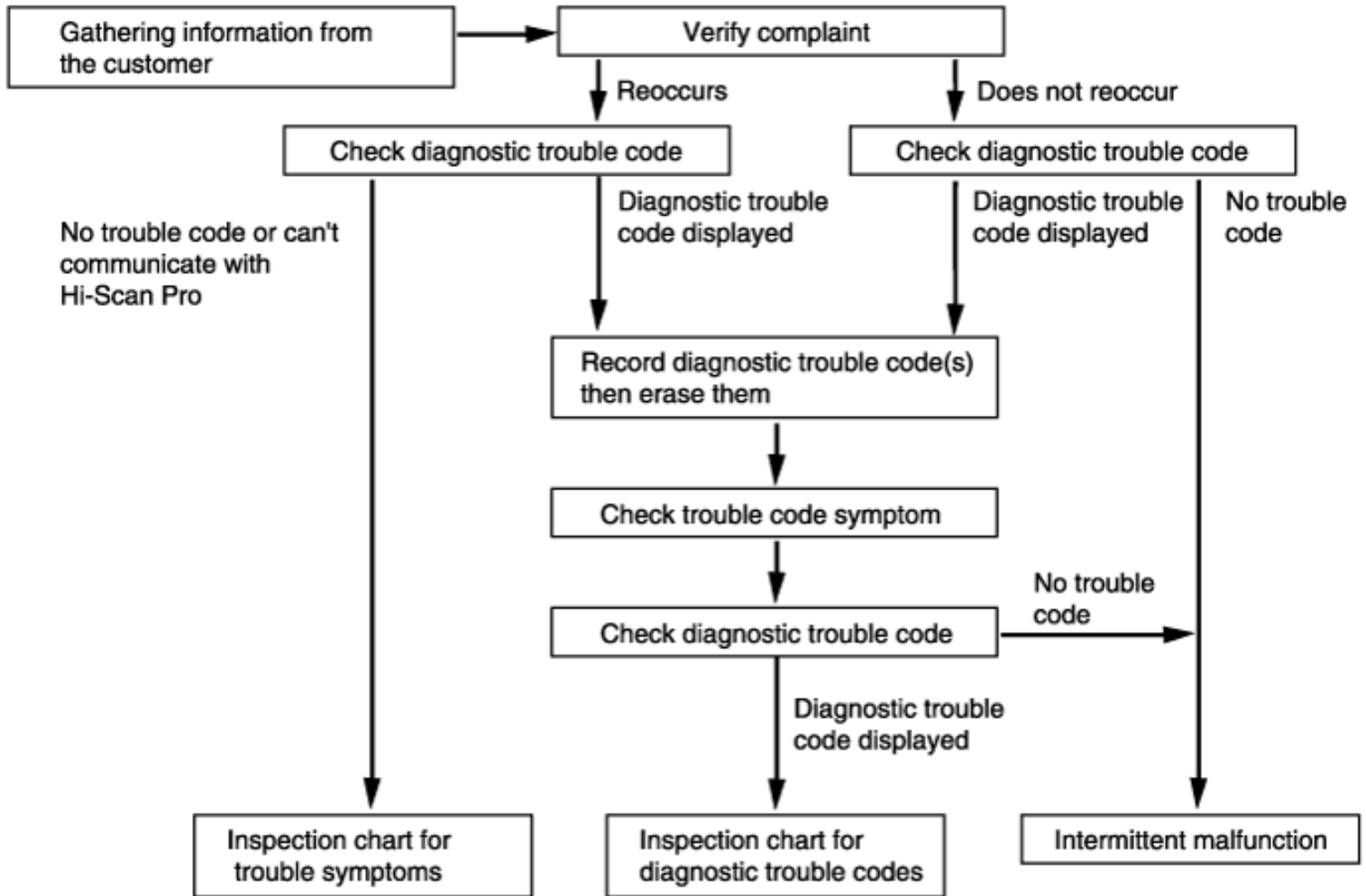

OPTION : DAB + PAB + SAB + BPT (ADVANCED AIRBAG)

DTC No.	Fault description
B1111	Battery voltage too high
B1112	Battery voltage too low
B1338	
B1339	Front impact sensor communication error
B1346	1st stage Driver airbag (DAB), Resistance too high

B1347	1st stage Driver airbag (DAB), Resistance too low 1st stage Driver airbag (DAB), Resistance too low
B1348	1st stage Driver airbag (DAB), Short to ground
B1349	1st stage Driver airbag (DAB), Short to battery
B1352	1st stage Passenger airbag (PAB), Resistance too high
B1353	1st stage Passenger airbag (PAB), Resistance too low
B1354	1st stage Passenger airbag (PAB), Short to ground
B1355	1st stage Passenger airbag (PAB), Short to Battery
B1361	Driver seat belt pretensioner (DBPT), Resistance too high
B1362	Driver seat belt pretensioner (DBPT), Resistance too low
B1363	Driver seat belt pretensioner (DBPT), Short to ground
B1364	Driver seat belt pretensioner (DBPT), Short to battery
B1367	Passenger seat belt pretensioner (PBPT), Resistance too high
B1368	Passenger seat belt pretensioner (PBPT), Resistance too low
B1369	Passenger seat belt pretensioner (PBPT), Short to ground
B1370	Passenger seat belt pretensioner (PBPT), Short to battery
B1378	Driver side airbag (DSAB), Resistance too high
B1379	Driver side airbag (DSAB), Resistance too low
B1380	Driver side airbag (DSAB), Short to ground
B1381	Driver side airbag (DSAB), Short to battery
B1382	Passenger side airbag (PSAB), Resistance too high
B1383	Passenger side airbag (PSAB), Resistance too low
B1384	Passenger side airbag (PSAB), Short to ground
B1385	Passenger side airbag (PSAB), Short to battery
B1387	Driver seat-track position sensor short to ground
B1388	Driver seat-track position sensor short to battery
B1389	Driver seat-track position sensor defect
B1390	Passenger seat-track position sensor short to ground
B1391	Passenger seat-track position sensor short to battery
B1392	Passenger seat-track position sensor defect
B1400	Side impact sensor driver side defect
B1403	Side impact sensor passenger side defect
B1409	Side impact sensor driver side communication error

B1410	Side impact sensor passenger side communication error
B1447	Passenger OC ECU defect
B1448	Passenger OC sensor defective.
B1449	Passenger OC communication error
B1450	Passenger OC wrong ID
B1481	2nd stage driver airbag, Resistance too high
B1482	2nd stage driver airbag, Resistance too low
B1483	2nd stage driver airbag, Short to ground
B1484	2nd stage driver airbag, Short to battery
B1485	2nd stage passenger airbag, Resistance too high
B1486	2nd stage passenger airbag, Resistance too low
B1487	2nd stage passenger airbag, Short to ground
B1488	2nd stage passenger airbag, Short to battery
B1511	Driver seat buckle switch short to battery
B1512	Driver seat buckle switch short to ground
B1513	Passenger seat belt switch short to battery
B1514	Passenger seat belt switch short to ground
B1515	Driver seat belt switch defect
B1516	Passenger seat belt switch defect
B1620	Internal failure
B1650	Crash recorded (Frontal)
B1651	Crash recorded driver side airbag (Side Airbag)
B1652	Crash recorded passenger side airbag (Side Airbag)
B1657	Crash recorded (Belt pretensioner only)
B1670	2nd stage crash recorded
B2500	Warning lamp failure
B2502	Tell tale lamp failure

NOTE

- The DAB is located in the steering wheel.
- The PAB is located in the crash pad.
- The DSAB is located in the left side of driver's seat.
- The PSAB is located in the right side of passenger's seat.