



HYUNDAI

Elantra



Workshop Manual
2001 - 2006

SERVICE ADJUSTMENT PROCEDURE

CHECKING STEERING WHEEL FREE PLAY

1. Start the engine with the steering wheel in the straight ahead position, apply a force of 5 N (1.1 lb) to the steering wheel in the peripheral direction.
2. Measure the play at the circumference of the steering wheel.

Standard value

Steering wheel free play : 0~30 mm (0~1.1 in)

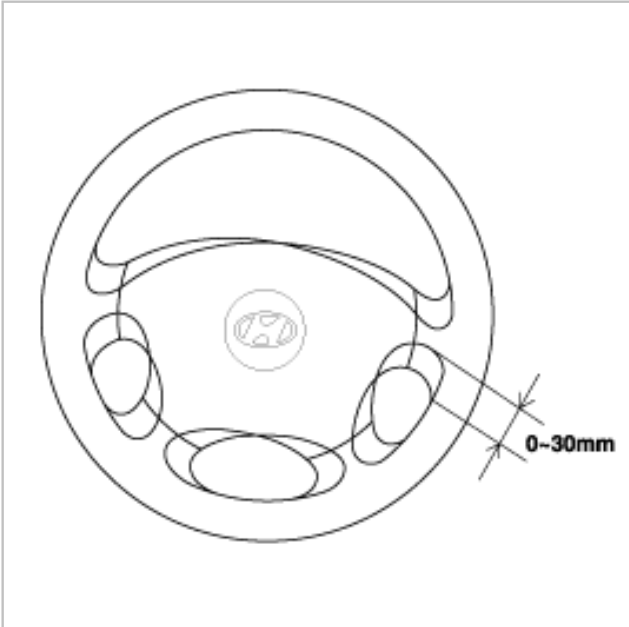

3. If the play exceeds the standard value, inspect the connection between the steering shaft and tie rod ends.

CHECKING STEERING ANGLE

1. Place the front wheel on a turning radius gauge and measure the steering angle.

Standard value

Wheel angle

Inner wheel : $40^{\circ}1' \pm 2^{\circ}$

Outer wheel : $33^{\circ}45'$

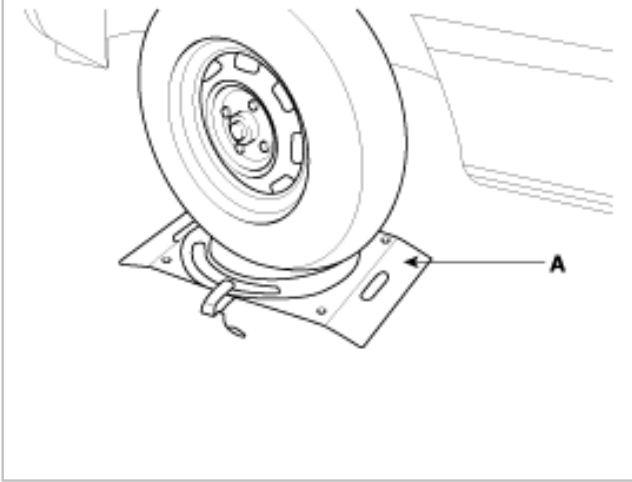

2. If the measured value is not within the standard value, adjust the linkage.

CHECKING THE TIE ROD END BALL JOINT STARTING TORQUE

1. Disconnect the tie rod(A) and knuckle(B) by using the special tool (09568-34000).

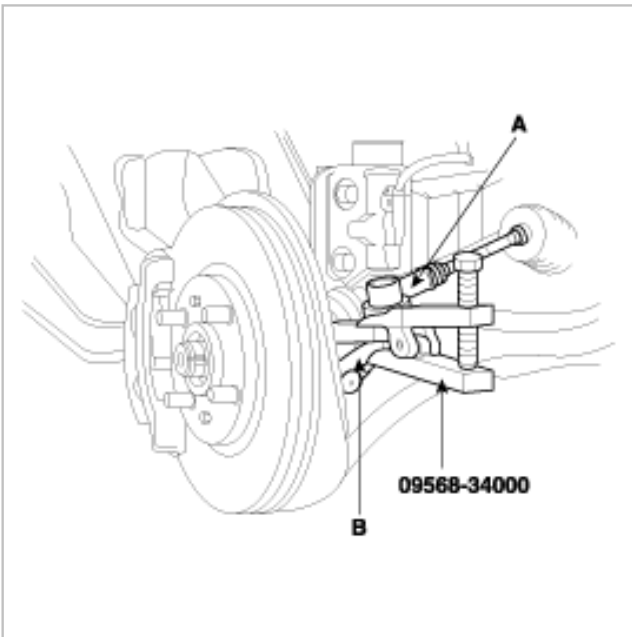

2. Shake the ball joint stud several times to check for looseness.
3. Mount the nuts on the ball joint, and then measure the ball joint starting torque.

Standard value

0.5~2.5 Nm (5~25 kg-cm, 0.36~1.78 lb-ft)

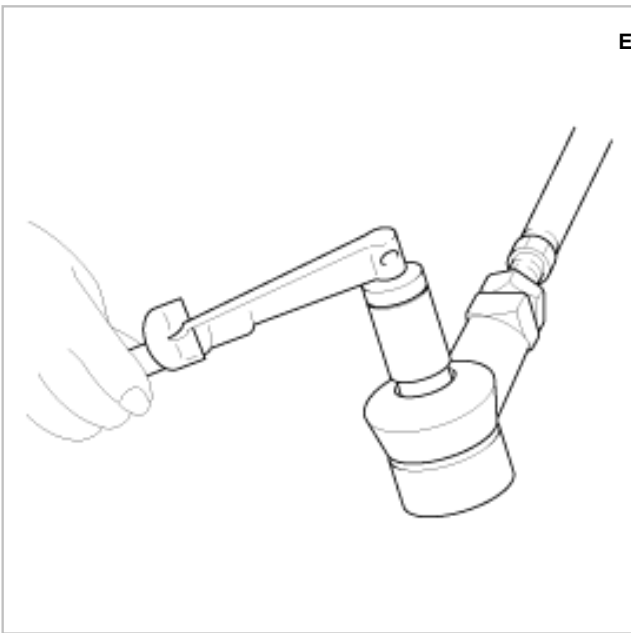

4. If the starting torque exceeds the upper limit of the standard value, replace the tie rod end.
5. Even if the starting torque is below the lower limit of the standard value, check the play of the ball joint and replace if necessary.

CHECKING STATIONARY STEERING EFFORT

1. Place the vehicle on a level surface and place the steering wheel in the straight ahead position.
2. Increase the engine speed to 1000 ± 100 rpm.

NOTE

After checking, reset the engine speed to the standard value (idling speed).

3. Measure the turning force with a spring scale(A) by turning the steering wheel(B) clockwise and counterclockwise one and a quarter turns.

Standard value

Stationary steering effort :
29 N (3.0 kg, 6.5lbs) or less

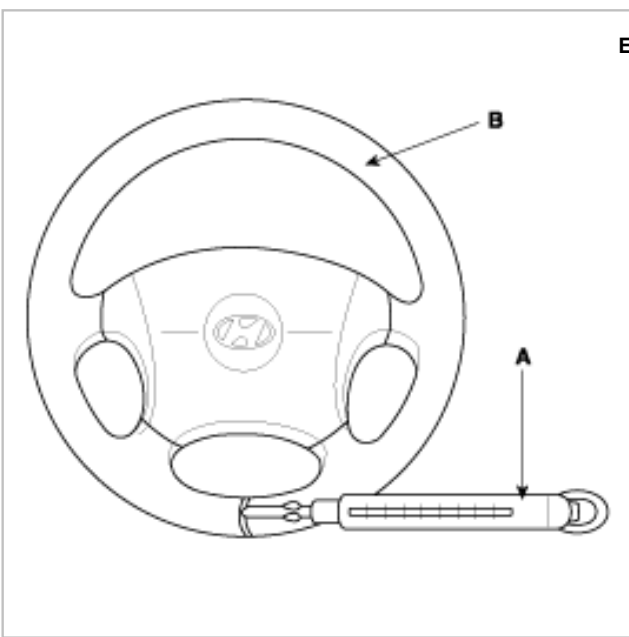

4. Check that there is no sudden change of force while turning the steering wheel.
5. If the stationary steering effort is excessive, check and adjust the following points.
 - (1) Damage or cracks on the dust cover of the lower arm ball joint and tie rod end.
 - (2) Pinion preload of the steering gear box and starting torque of the tie rod end ball joint.
 - (3) Starting torque of the ball joint.

CHECKING STEERING WHEEL RETURN

1. The force required to turn the steering wheel and the wheel return should be the same for both left and right in case of moderate or sharp turns.
2. When the steering wheel is turned 90° and held for a couple of seconds while the vehicle is being driven at 35kph, the steering wheel should return to within 20° from the neutral position when it is released.

NOTE

If the steering wheel is turned very quickly, steering may be momentarily difficult. This is not a malfunction because the oil pump output will be somewhat decreased.

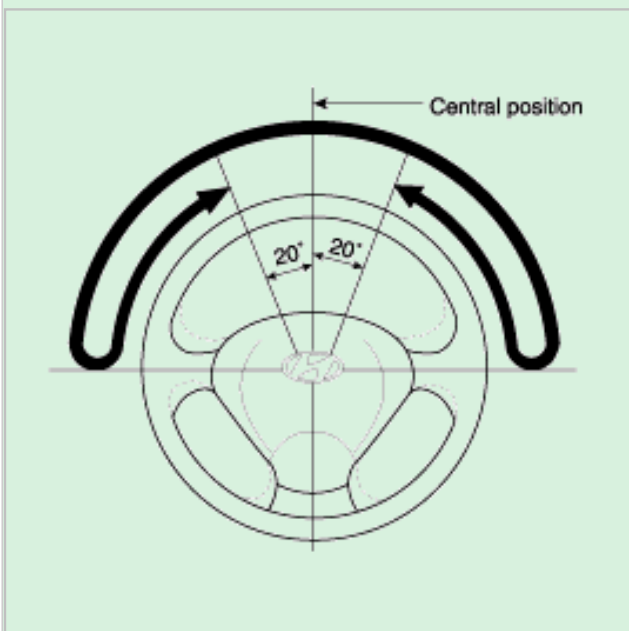

CHECKING POWER STEERING BELT TENSION

Ebay User ID: reveleus1

1. Press the V belt, applying a pressure of 98N (10kg, 22lb) at the specified point and measure the deflection to confirm that it is within the standard value.

Standard value

V belt deflection : 6~9 mm

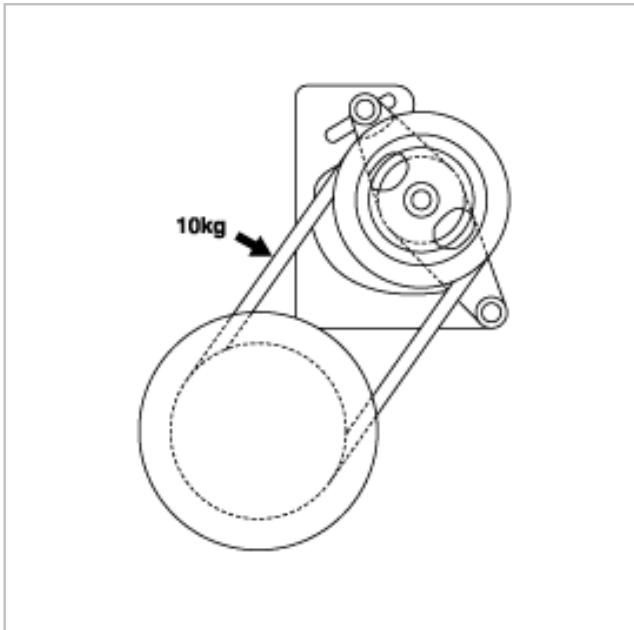

2. If the belt deflection is beyond the standard value, adjust the belt tension as follows.
 - (1) Loosen the bolt adjusting(A) the power steering "V"belt tension.

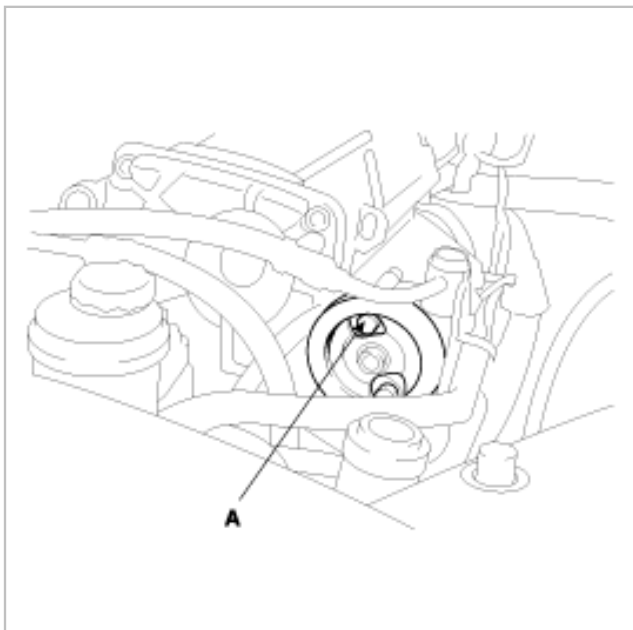

- (2) Put a bar(A) or equivalent, between the bracket(B) and the oil pump(C) and adjust the tension so that the belt deflection is within the standard value.

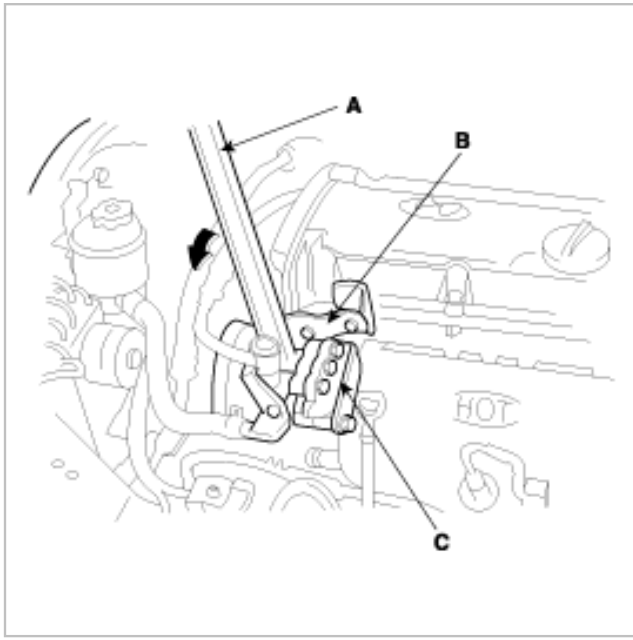

- (3) Tighten the bolt adjusting the power steering "V"belt tension.
(4) Check the belt deflection and adjust it again if necessary.

CAUTION

After turning the V belt in the normal rotation direction more than once, recheck the belt deflection.

CHECKING POWER STEERING FLUID LEVEL

1. Position the vehicle on a level surface.
2. Start the engine. With the vehicle kept stationary, turn the steering wheel several times continuously to raise the fluid temperature to 50 - 60°C(122 to 140°F).
3. With the engine at idle, turn the steering wheel fully clockwise and counterclockwise several times.
4. Make sure there is no foaming or cloudiness in the reservoir fluid.
5. Stop the engine to check for any difference in fluid level between a stationary and a running engine.

NOTE

1. If the fluid level varies 5 mm (0.2 in.) or more, bleed the system again.
2. If the fluid level suddenly rises after stopping the engine, further bleeding is required.

3. Incomplete bleeding will produce a chattering sound in the pump and noise in the flow control valve, and lead to decreased durability of the pump.

Ebay User ID: reveleus1

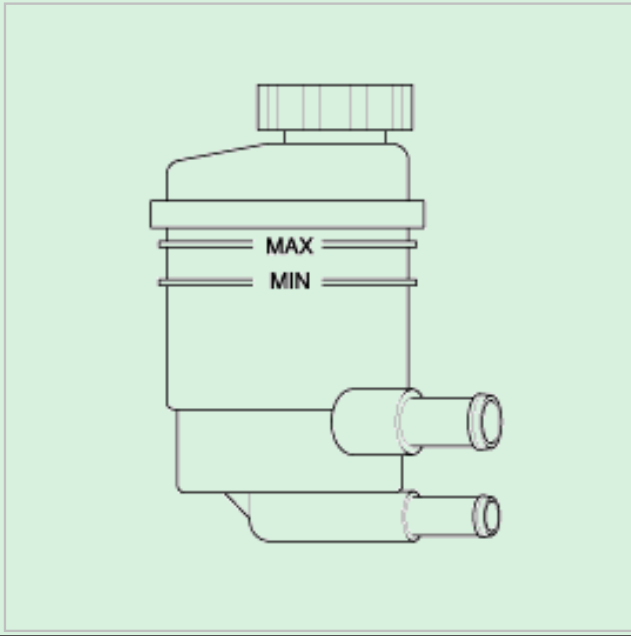

REPLACING POWER STEERING FLUID

1. Jack up the front wheels of the car and support them with jackstands.
2. Disconnect the return hose from the oil reservoir and plug the oil reservoir.
3. Connect a hose to the disconnected return hose, and drain the oil into a container.
4. Disconnect the high-tension cables and ignition coils.

While operating the starter motor intermittently, turn the steering wheel all the way to the left and then to the right several times to drain the fluid.

5. Connect the return hose and fix it with a clip.
6. Fill the power steering fluid reservoir with the specified fluid.

PSF-3 : 0.75~0.8 lit.

7. Start the engine.
Check for fluid leaks from the hose, then stop the engine.
8. Pour the fluid into the bottom of the oil filter in the power steering fluid reservoir.
9. Bleed the air.

AIR BLEEDING

1. Fill the power steering fluid reservoir up to the "MAX" position with specified fluid.
2. Jack up the front wheels.

3. Disconnect the ignition coil high tension cable, and then, while operating the starter motor intermittently (for 15 to 20 seconds), turn the steering wheel all the way to the left and then to the right five or six times.

NOTE

1. When bleeding fluid, replenish with the fluid so that the level does not fall below the bottom of the filter.
2. If air bleeding is done while the vehicle is idling, the air will be broken up and absorbed into the fluid. Be sure to do the bleeding only while cranking.

4. Connect the high tension cable, and then start the engine (idling).
5. Turn the steering wheel to the left and then to the right, until there are no air bubbles in the oil reservoir.

NOTE

Do not hold the steering wheel turned all the way to either side for more than ten seconds.

6. Confirm that the fluid is not milky and that the level is between "MAX" and "MIN" mark on the reservoir.
7. Check that there is a little change in the fluid level when the steering wheel is turned left and right.

NOTE

1. If the fluid level varies 5mm (0.2 in.) or more, bleed the system again.
2. If the fluid level suddenly rises after stopping the engine, further bleeding is required.
3. Incomplete bleeding will produce a chattering sound in the pump and noise in the flow control valve, and lead to decreased durability of the pump.

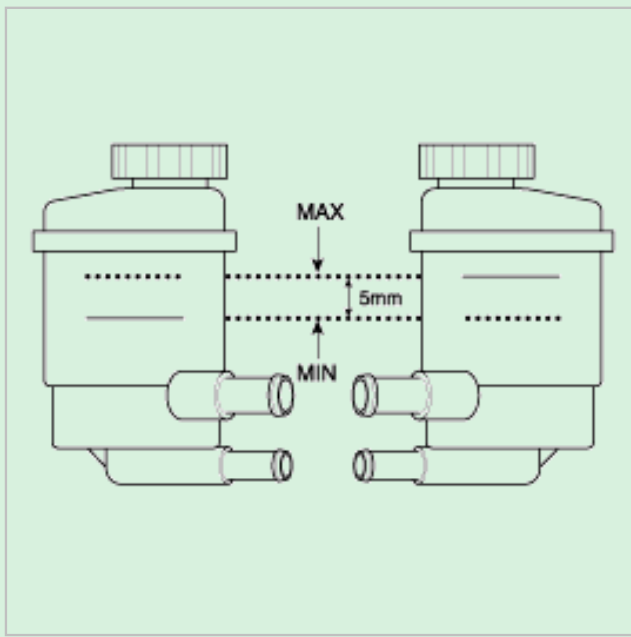

OIL PUMP PRESSURE TEST

1. Disconnect the pressure hose(B) from the pump(A). Connect the special tool between the pump and the pressure hose as illustrated.
2. Bleed the air, and then start the engine and turn the steering wheel several times, measure the fluid temperature by Temperature gauge (D) so that the fluid temperature can rise to approximately 50°C (122°F).
3. Increase the engine speed to 1,000 rpm.

4. Close the shut-off valve of the special tool and measure the fluid pressure to confirm that it is within the standard value range.

Ebay User ID: reveleus1

Standard value

Oil pump pressure

Relief pressure :

8.3~8.8 MPa (85~90 kg.cm², 1209~1280 psi)

CAUTION

Do not keep the shut-off valve on the pressure gauge closed for more than ten seconds.

5. Remove the special tools, and tighten the pressure hose(B) against the oil pump (A) using the specified torque.

Tightening torque

55~65 Nm (550~650 kg.cm, 40.6~47.9 lb.ft)

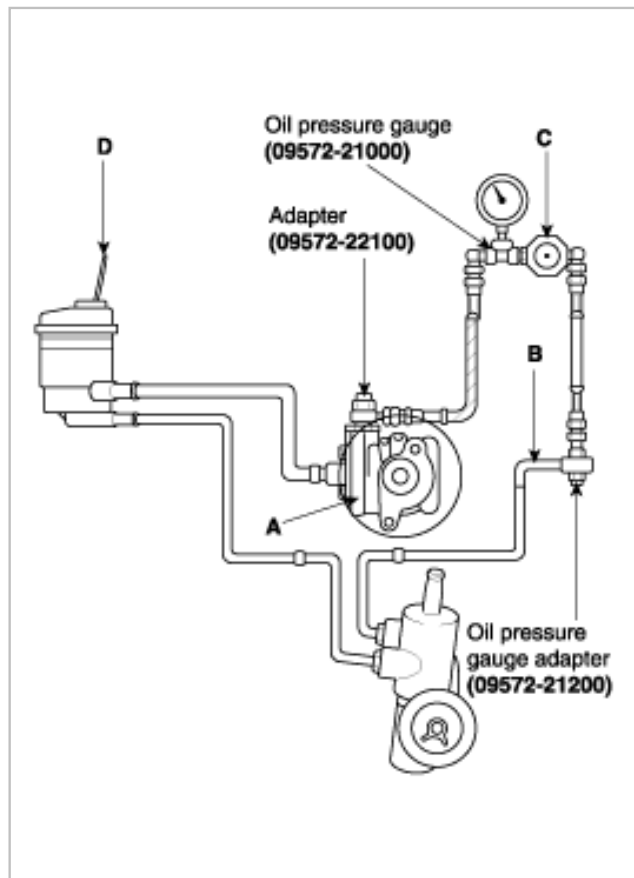

COMPONENTS

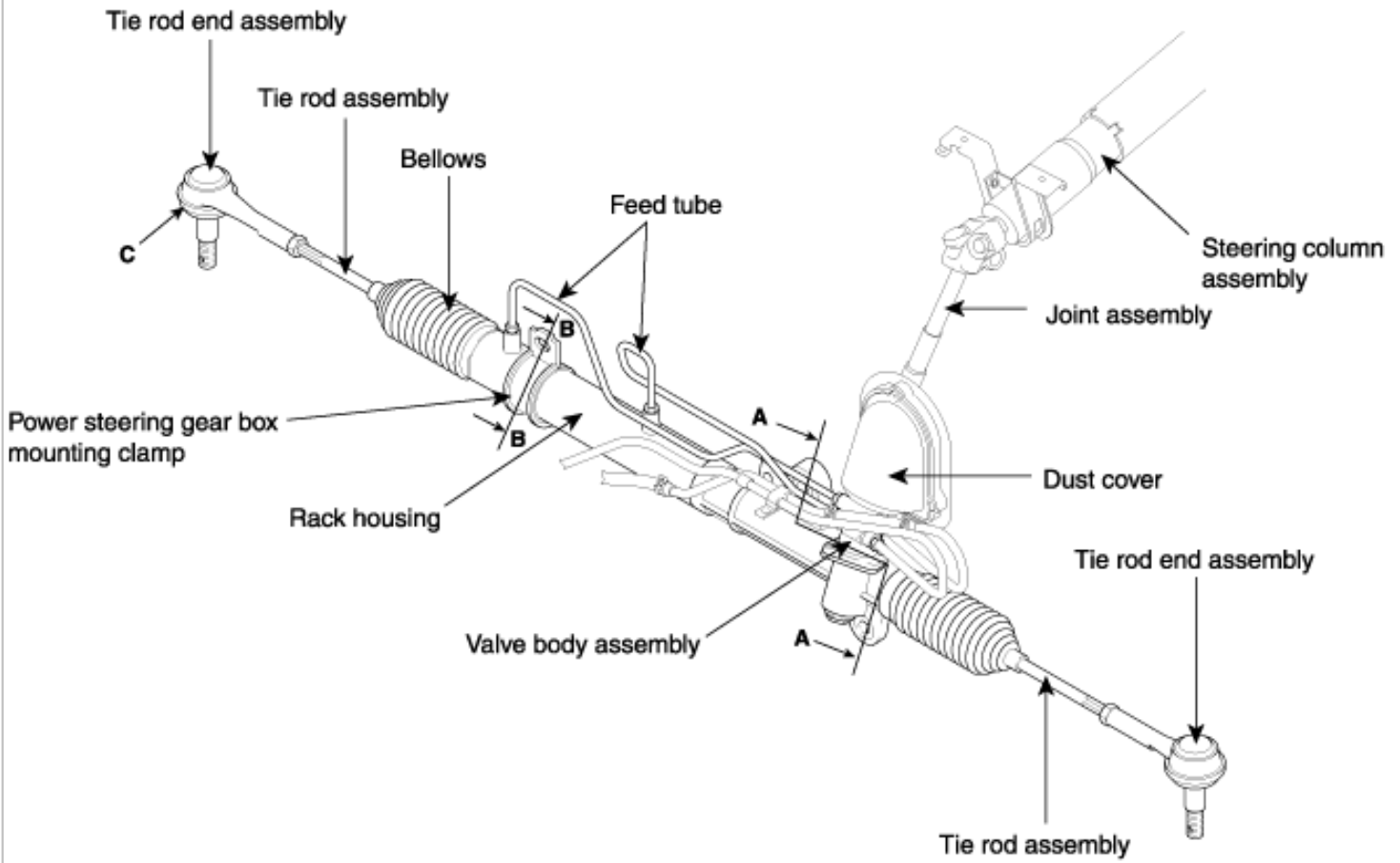

[VIEW A]

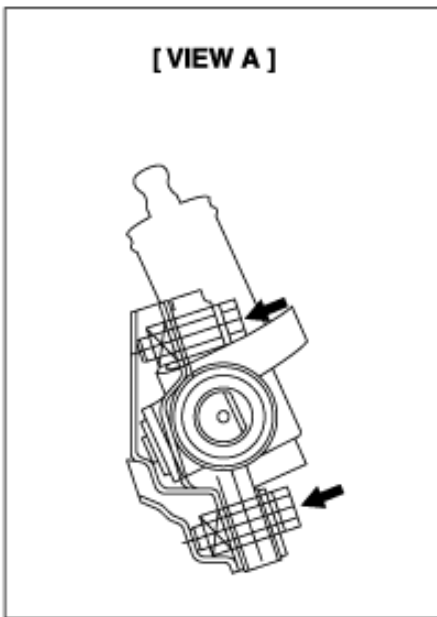

[VIEW B]

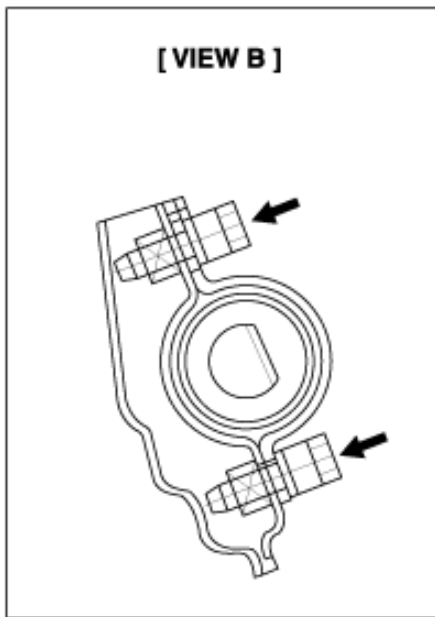

[VIEW C]

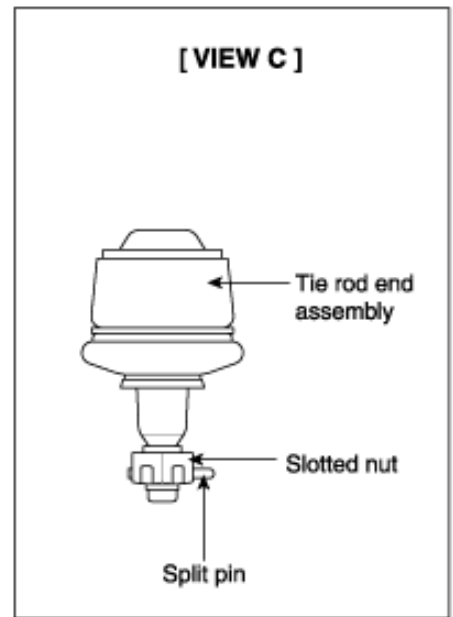

DISASSEMBLY AND ASSEMBLY

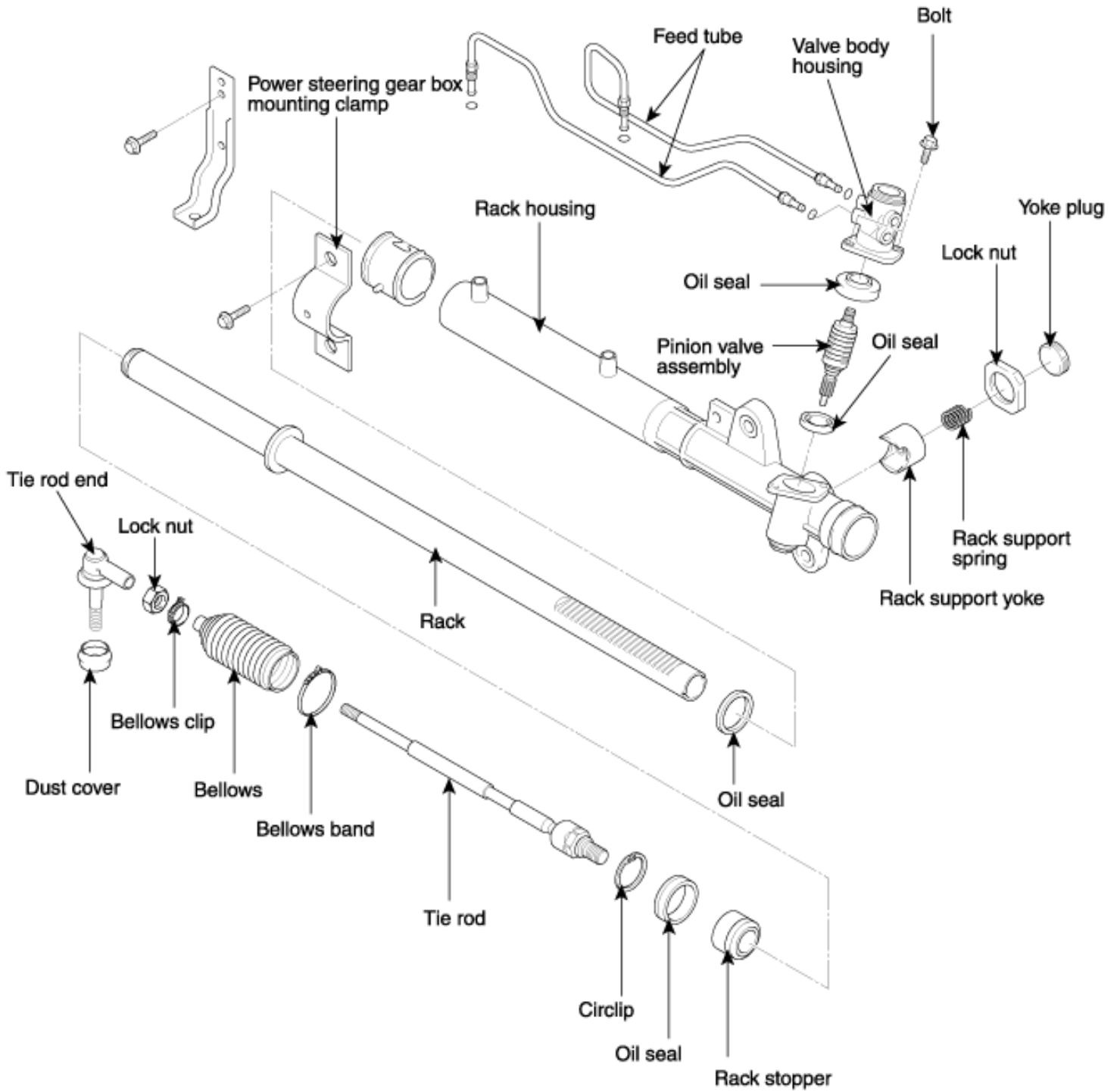

REMOVAL

1. Remove the air intake hose assembly(A).

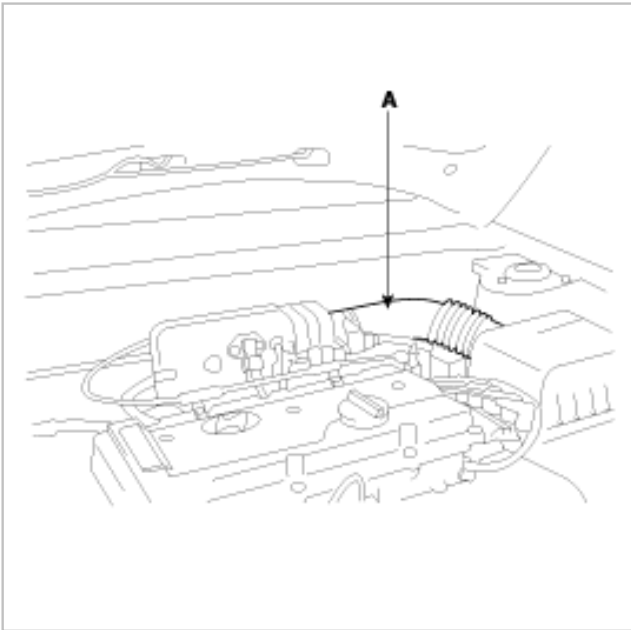

2. Detach the power steering pressure hose mounting clamp and the return tube mounting clamp.
3. Drain the power steering fluid.
4. Disconnect the pressure tube and the return tube fittings from the gear box.
5. Disconnect the shaft assembly(A) from the gear box inside the passenger compartment.

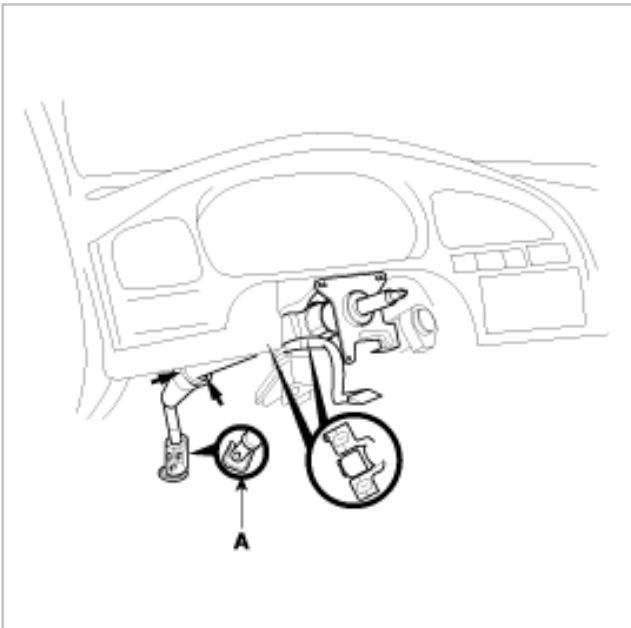

6. Remove the strap and push out the dust cover and remove the dust cover mounting plate.
7. Raise up the vehicle.
8. Remove the front tires (RH/LH).

9. After removing the split pin, disconnect the tie rod(A) from the knuckle(B) by using the special tool (09568-31000).

Ebay User ID: reveleus1

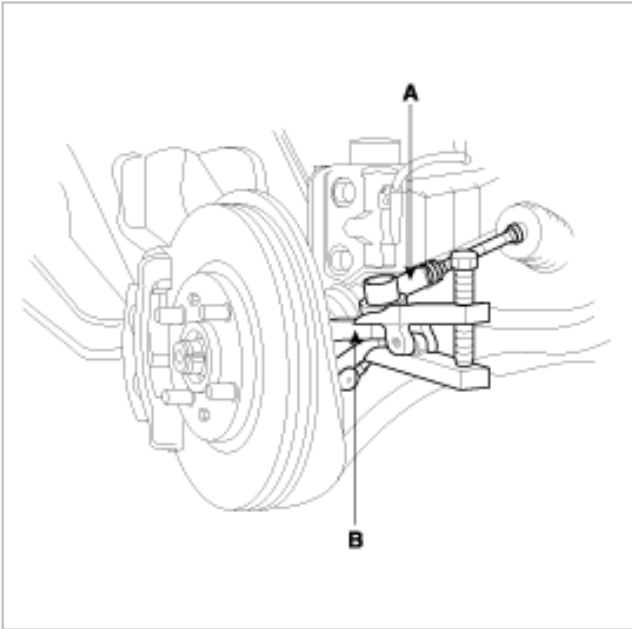

10. Remove the stabilizer bar(A) (RH side) mounting bracket(B).

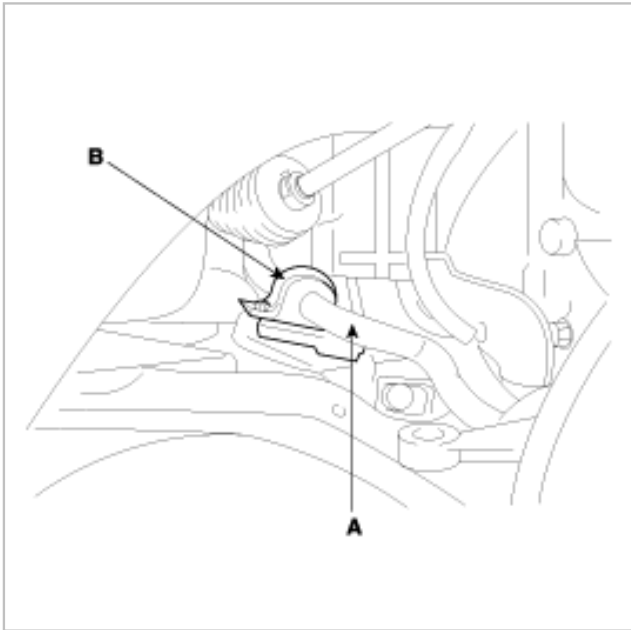

11. Remove the front muffler assembly(A).

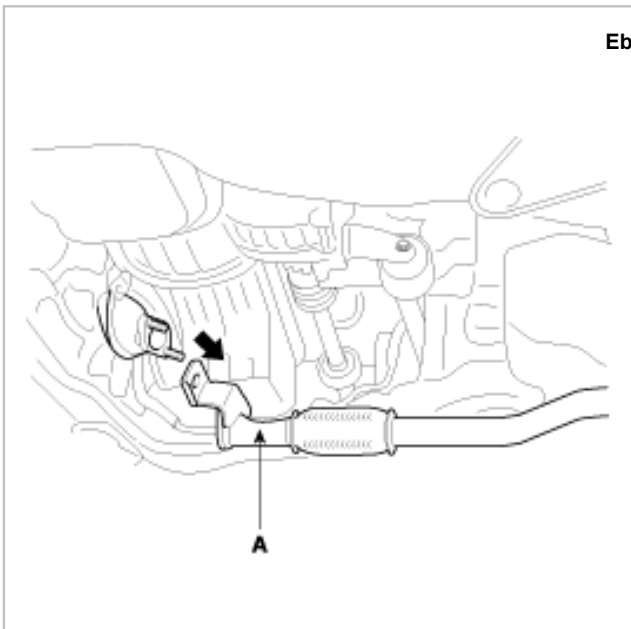

12. Remove the mounting bolt and mounting clamp(A) of power steering gear box, and also remove the clamp(B) holding the pressure tube and the return tube.

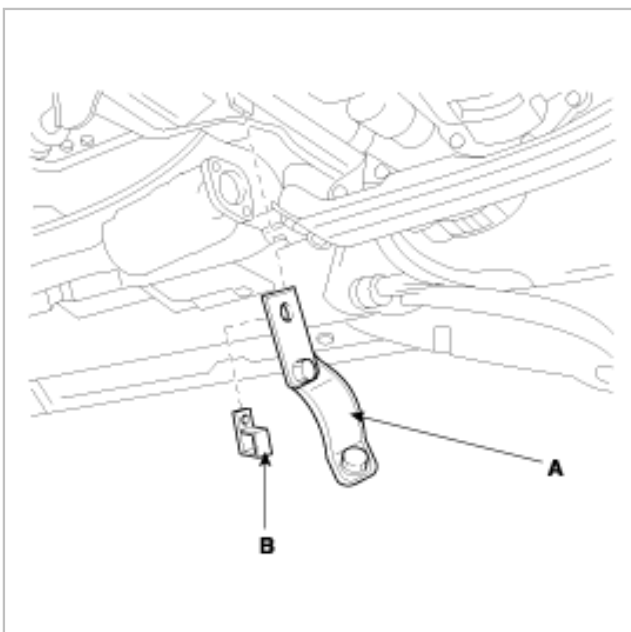

13. Pull the power steering gear box assembly(A) toward the right side of the vehicle.

NOTE

When removing the gear box, pull it out carefully and slowly so as not to cause damage to the boots(B).

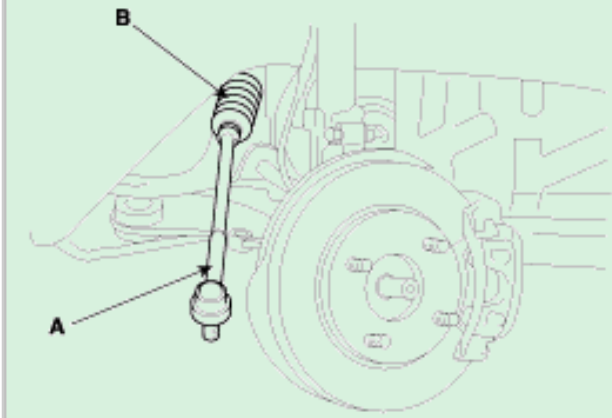

INSTALLATION

1. Push in the power steering gear box assembly(A) on the right side of the vehicle.

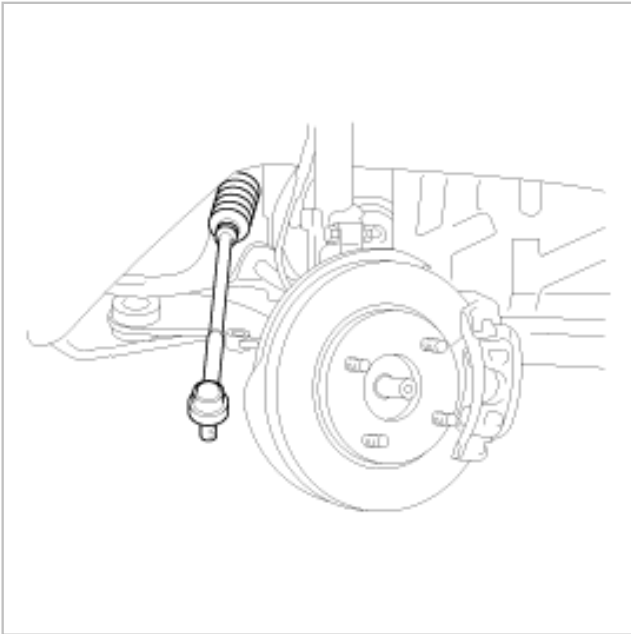

2. Install the dust cover mounting plate.
3. Connect the dust cover to its mounting plate with a new strap.

4. Connect the steering gear box assembly(A) to the steering column shaft and universal joint assembly(B).

Ebay User ID: reveleus1

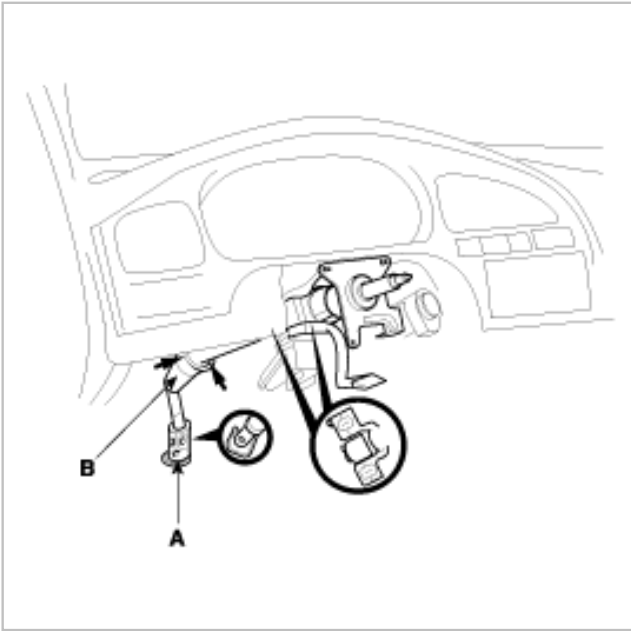

5. Installation is the reverse of removal.

6. After installation, air bleed the system.

DISASSEMBLY

1. Remove the tie rod, end(B) from the tie rod(A).

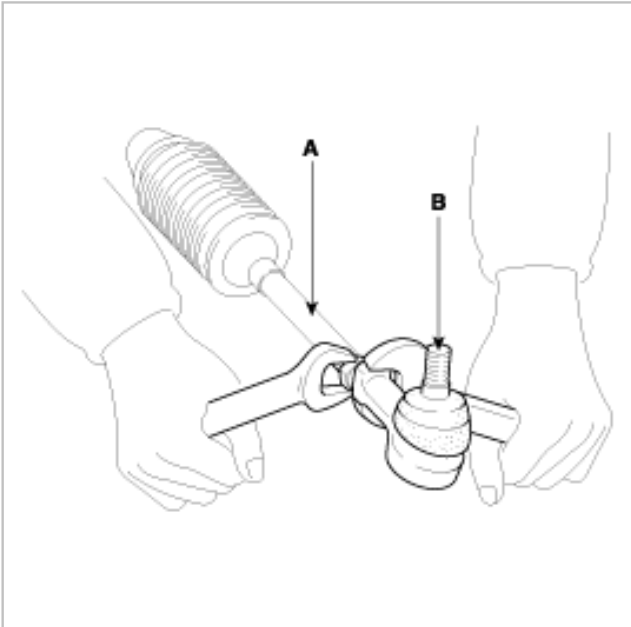

2. After mounting the tie rod end(A) in a vise, remove the dust cover(B) from the ball joint.

Ebay User ID: reveleus1

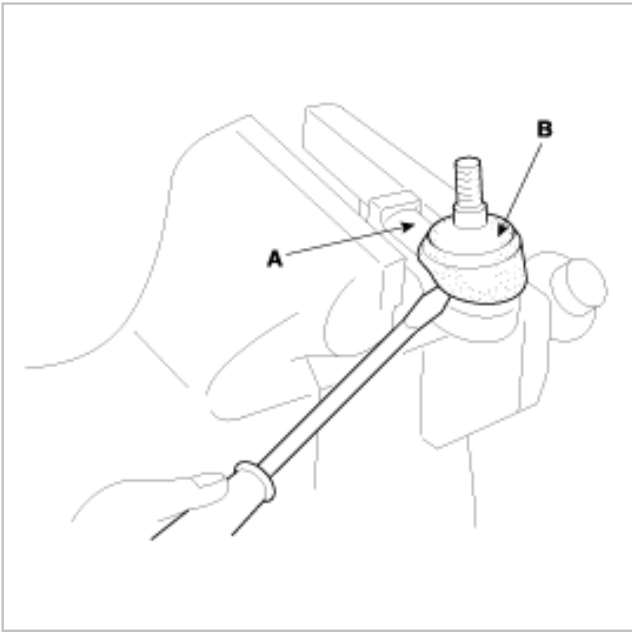

3. Remove the bellows band(A).

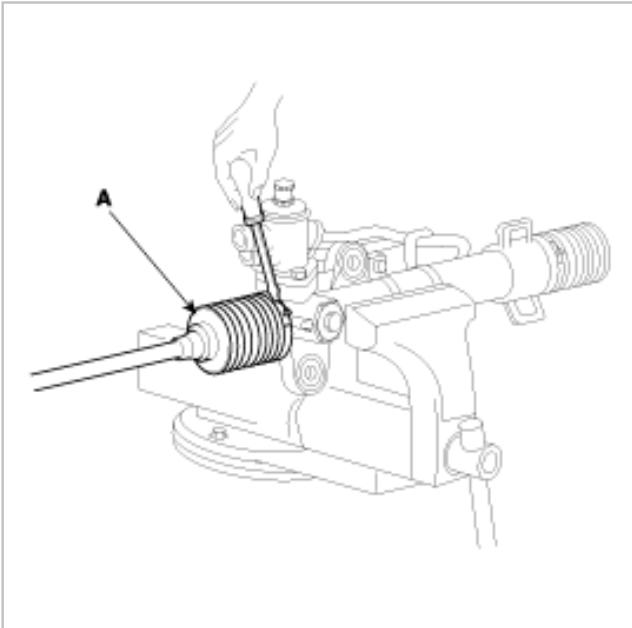

4. Remove the bellows clip(A).

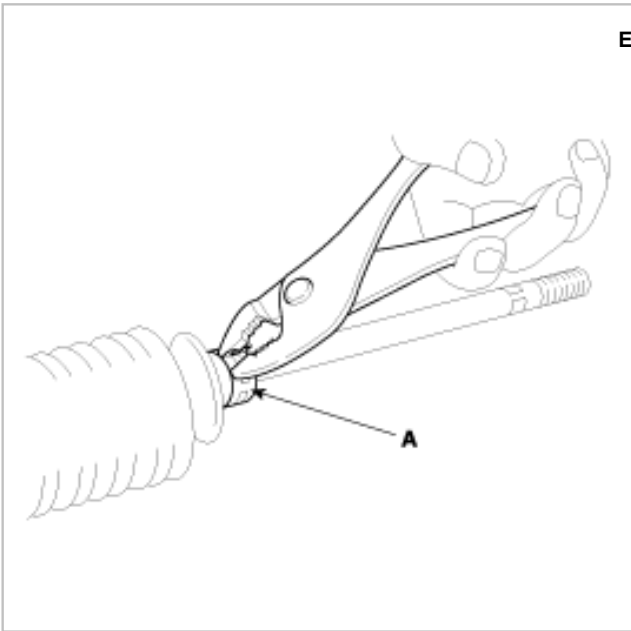

5. Pull the bellows out toward the tie rod.

NOTE

Check for rust on the rack when the bellows are replaced.

6. Remove the feed tube from the rack housing.

7. While moving the rack slowly, drain the fluid from the rack housing.

8. Unstake the tab washer(A) which fixes the tie rod(B) and rack(C) with a chisel.

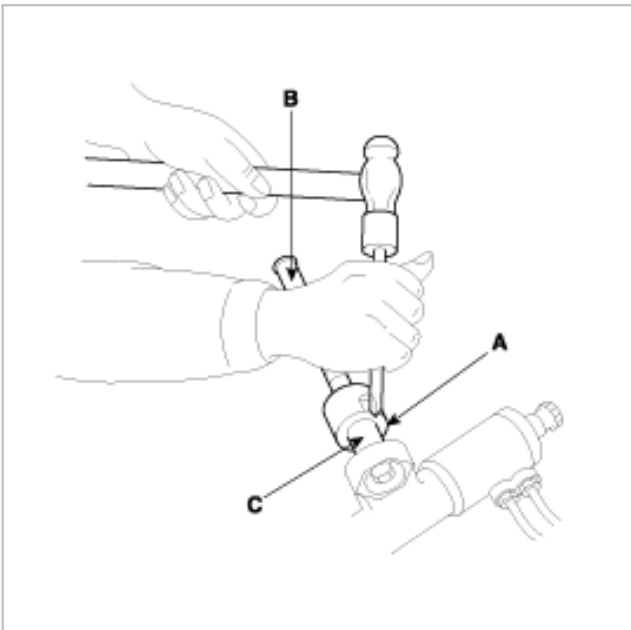

9. Remove the tie rod(B) from the rack(C).

Ebay User ID: reveleus1

CAUTION

Remove the tie rod(B) from the rack(A), taking care not to twist the rack.

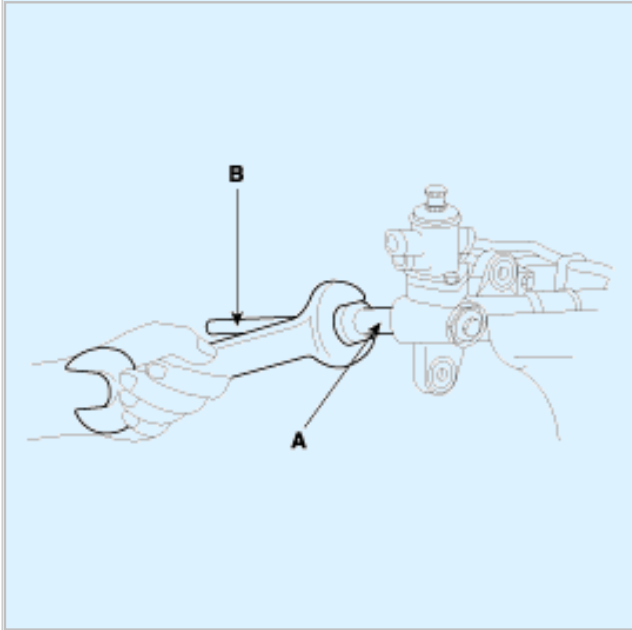

10. Remove the yoke plug locking nut(A).

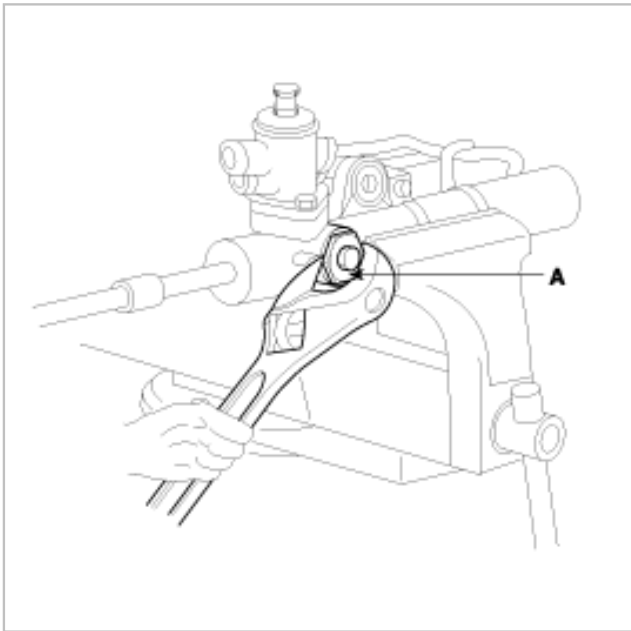

11. Remove the yoke plug(B) with a 14mm socket(A)

Ebay User ID: reveleus1

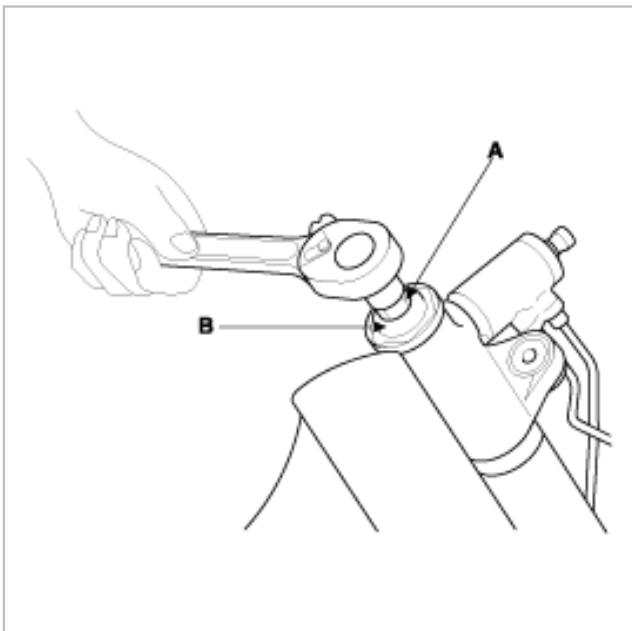

12. Remove the lock nut(A), yoke plug(B), rack support spring(C), rack support yoke(D) and bushing(E) from the gear box.

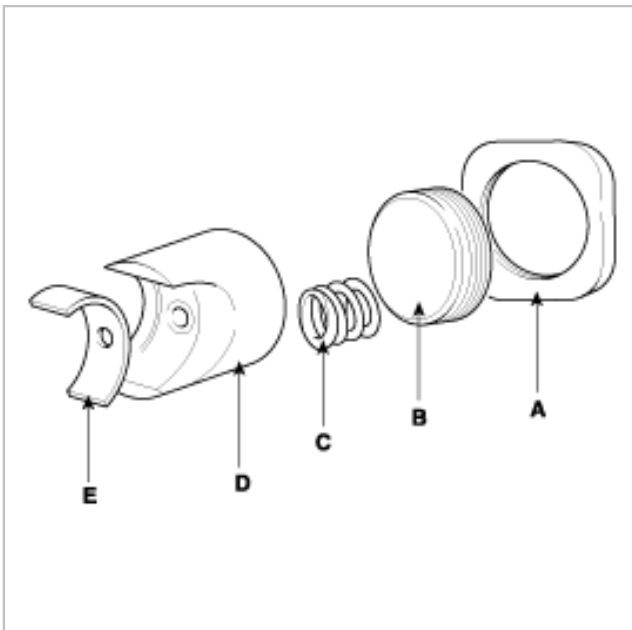

13. Remove the valve body housing(A) by loosening the two bolts(B).

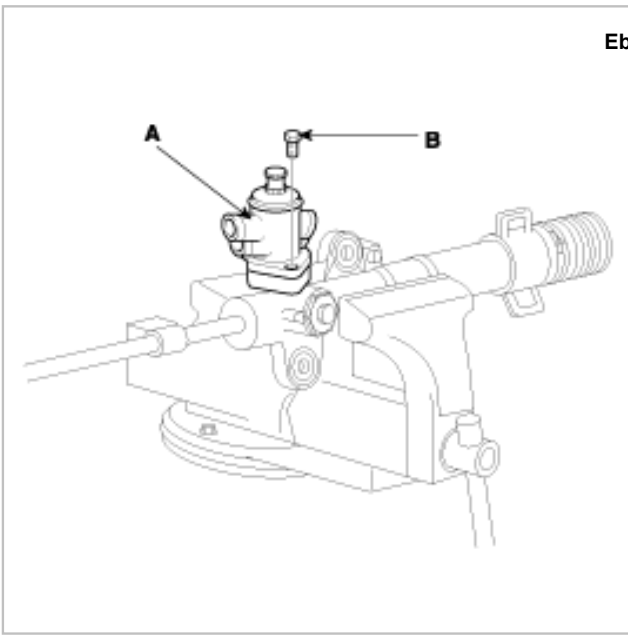

14. Turn the rack stopper(A) clockwise until the end of the circlip(B) comes out of the slot in the rack housing(C).

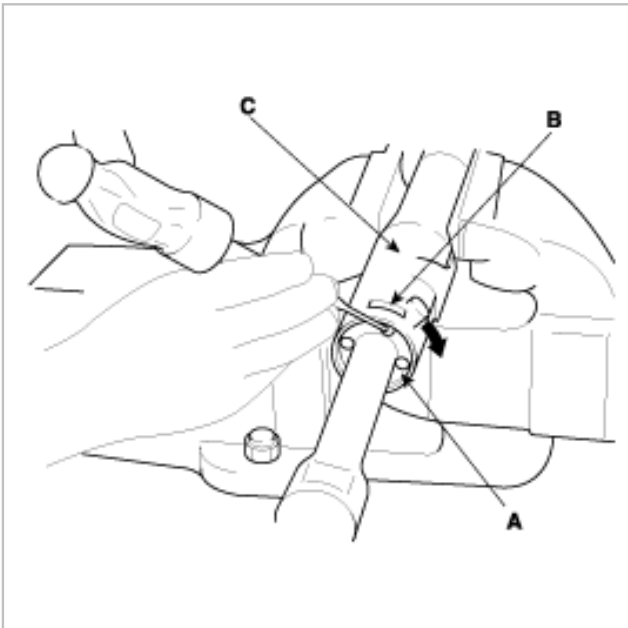

15. When the end of the circlip(A) comes out of the notched hole of the housing rack cylinder, turn the rack stopper(B) counterclockwise and remove the circlip(A).

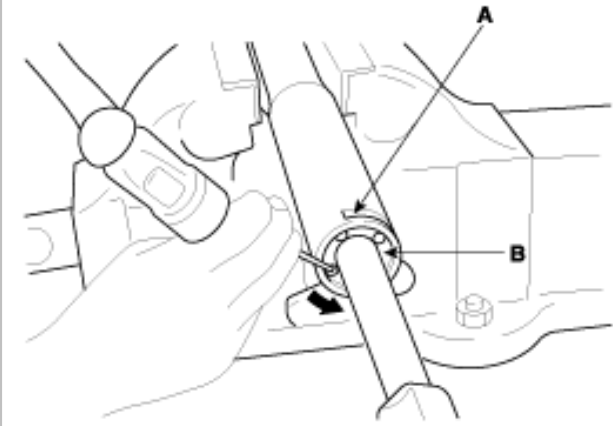

16. Remove the O-ring(A) from the rack bushing(B).

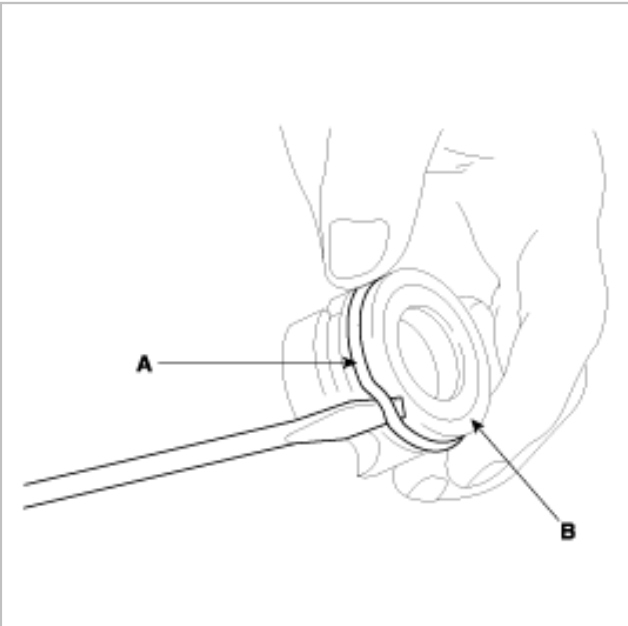

17. Remove the oil seal(A) from the rack bushing(B).

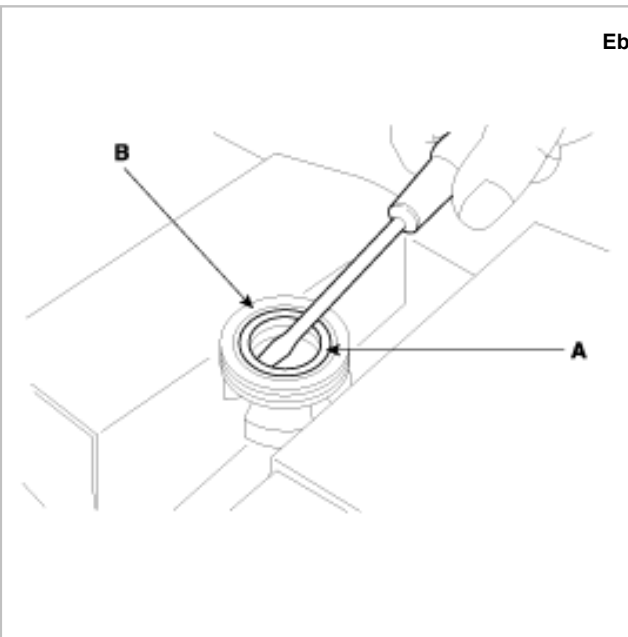

18. Remove the valve body(A) from the valve body housing(B) with a soft hammer(C).

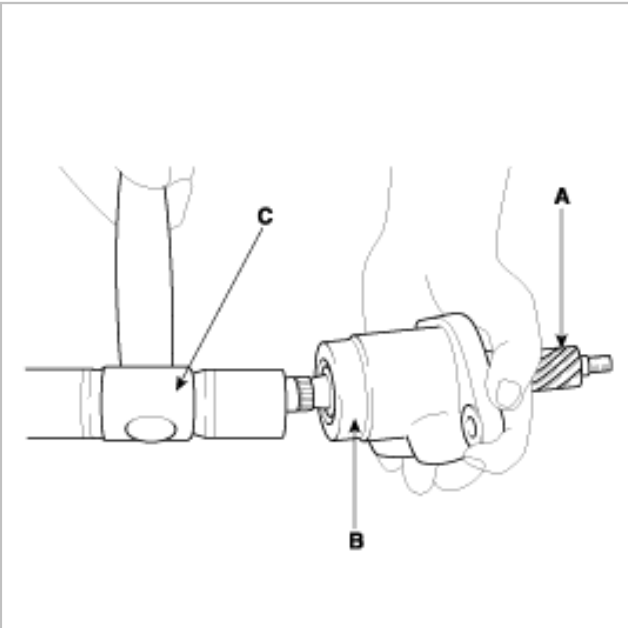

19. Using the special tool, remove the oil seal and ball bearing from the valve body housing.

20. Remove the oil seal and O-ring from the rack housing.

CAUTION

Be careful not to damage the pinion valve cylinder inside of the rack housing.

21. Using the special tool(06573-21200, 09555-21000), remove the oil seal(A) from the rack housing.
Ebay User ID: reveleus1

CAUTION

Be careful not to damage the rack cylinder inside of the rack housing.

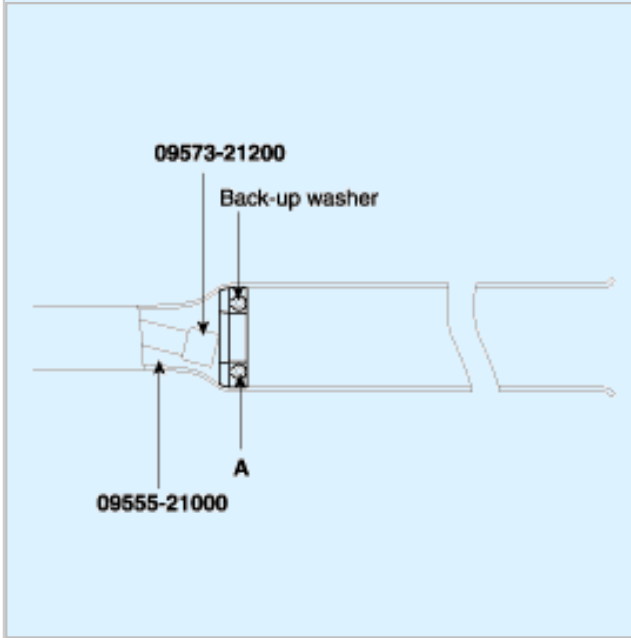

REASSEMBLY

1. Apply the specified fluid to the entire surface of the rack oil seal.

Recommended fluid : PSF-3

2. Install the backup washer and oil seal(A) to the specified position in the rack housing.

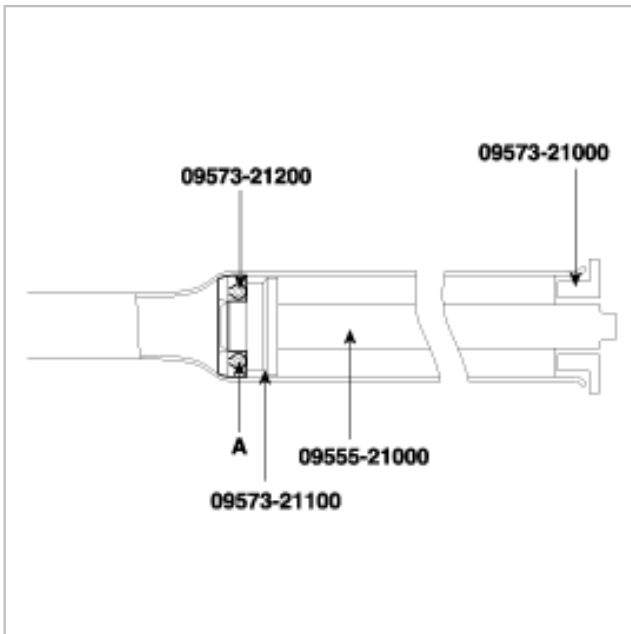

3. Apply the specified fluid to the entire surface of the rack bushing oil seal.

Recommended fluid : PSF-3

4. Install the oil seal(A) in the rack bushing(B).

Ebay User ID: reveleus1

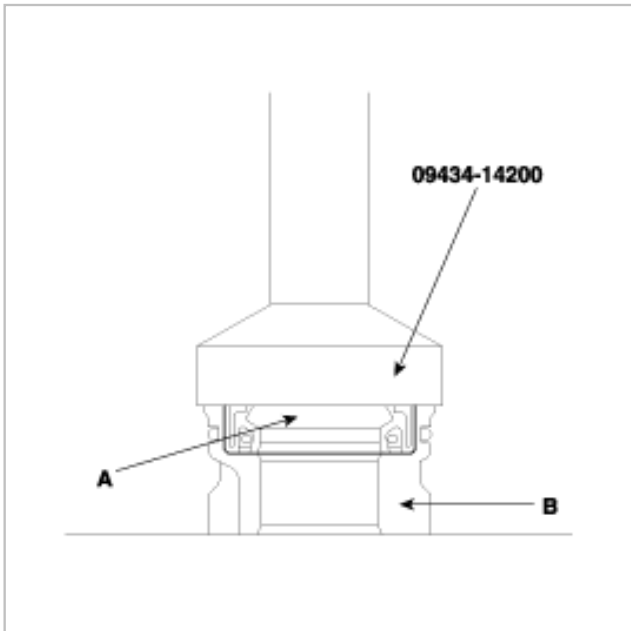

5. Apply the specified fluid to the entire surface of the O-ring and install it in the rack bushing.

6. Apply the specified grease to the rack teeth.

Recommended grease

Multipurpose grease SAE J310, NLGI No.2

NOTE

Do not plug the vent hole(A) in the rack with grease.

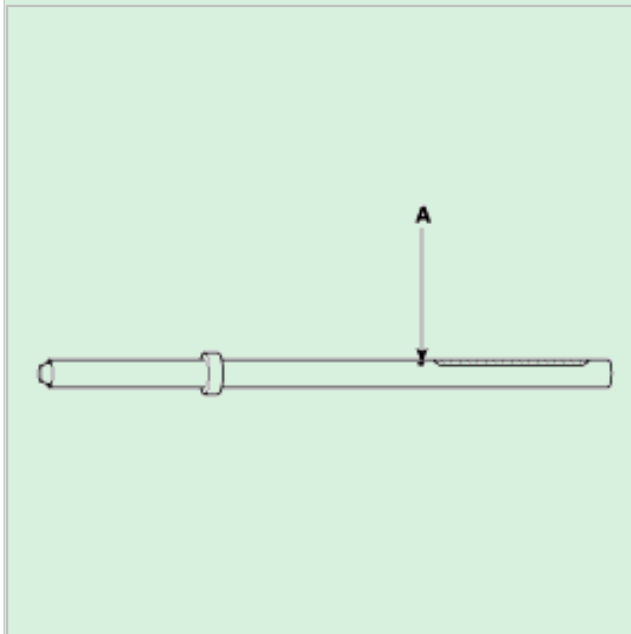

7. Insert the rack(A) into the rack housing(B) and install the rack bushing(C) and rack stopper(D).

Ebay User ID: reveleus1

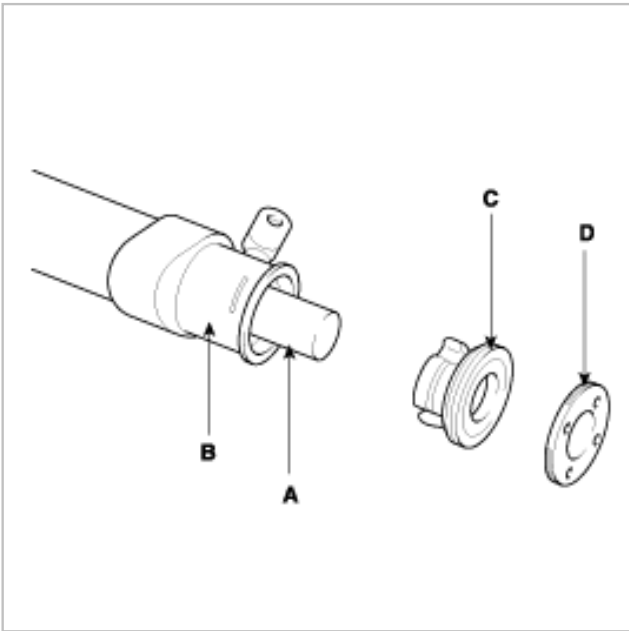

8. Push in the rack stopper until the circlip groove of the rack stopper is aligned with the notched hole of the rack housing. Install the circlip(A) while turning the rack stopper.

CAUTION

The circlip end should not be visible through the notched hole of the rack housing.

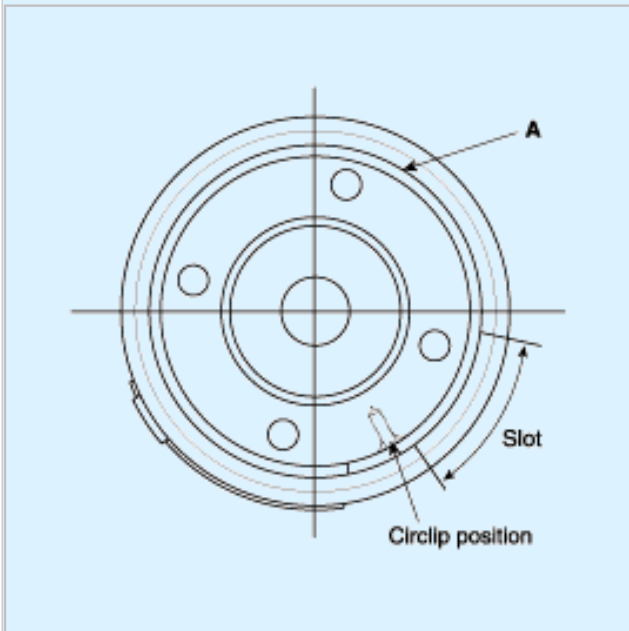

9. Install the oil seal and the ball bearing in the valve body(A).
Ebay User ID: reveleus1

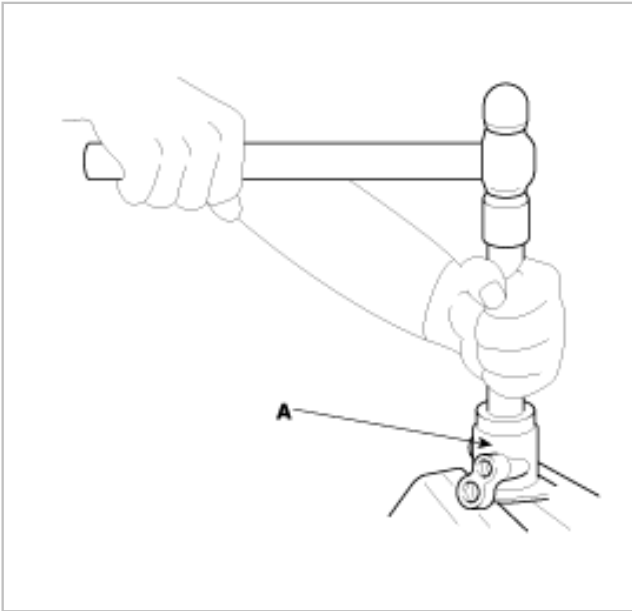

10. After applying the specified fluid and grease to the pinion valve assembly(A), install it in the rack housing assembly.

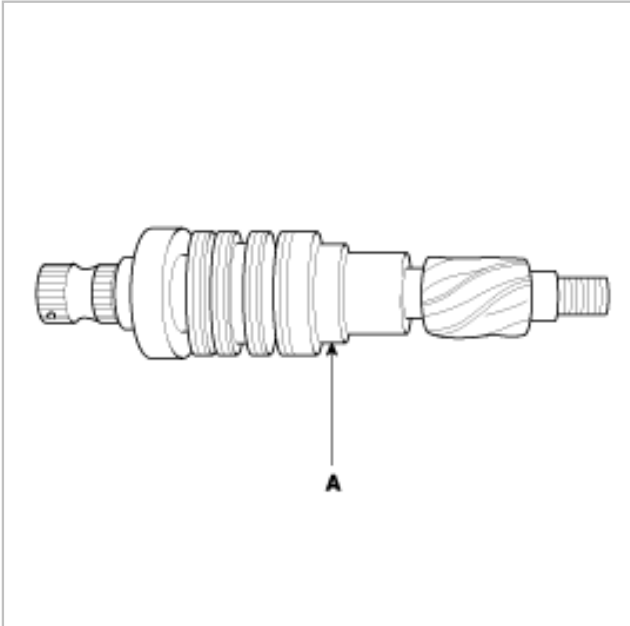

11. After applying the specified fluid to the oil seal, install it in the rack housing, and fix the valve body assembly (A) and O-ring in the gear box(B).

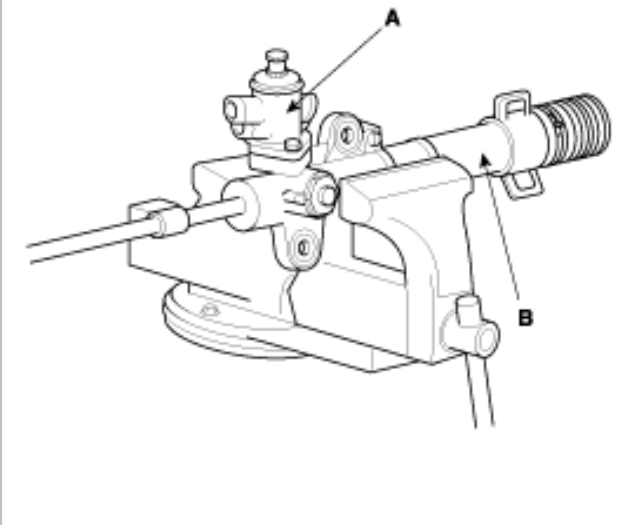

12. Install the tab washer and the tie rod and stake the tab washer(A) end at two points over the tie rod.

NOTE

1. Align the tab washer pawls with the rack grooves.
2. Always use a new tab washer.

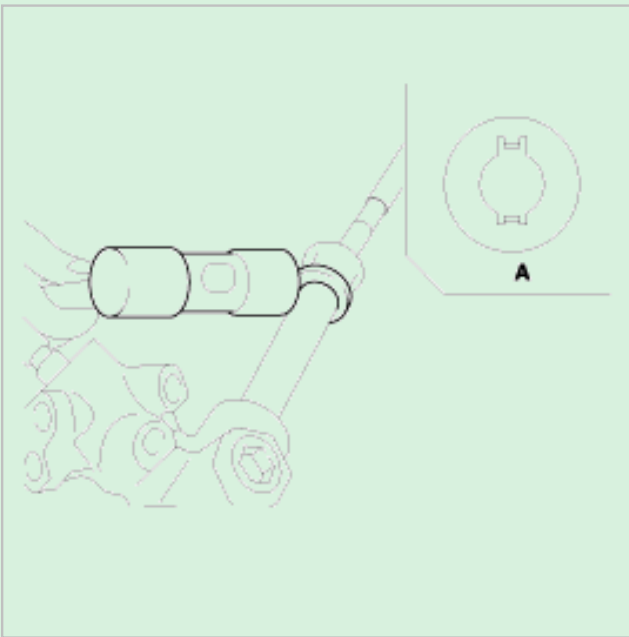

13. Install the bushing(A), rack support yoke(B), rack support spring(C), lock nut(E) and yoke plug(D) in the order shown in the illustration. Apply semi-drying sealant to the threaded section of the yoke plug before installation.

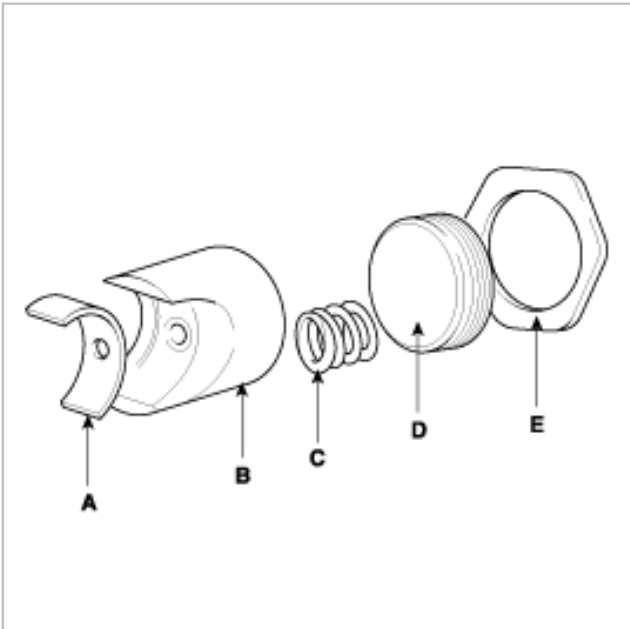

14. With the rack placed in the center position, attach the yoke plug to the rack housing. Tighten the yoke plug to 15 Nm (150 kg.cm, 11 lb.ft), using the special tool. Loosen the yoke plug approximately from 30° to 60° and tighten the locking nut to the specified torque.

Tightening torque

50~70 Nm (500~700 kg.cm, 37~52 lb.ft)

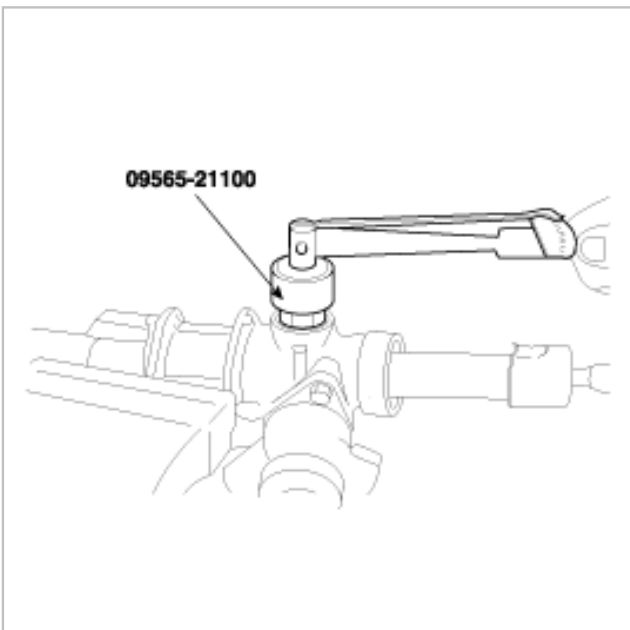

15. Tighten the feed tube to the specified torque and install the mounting rubber using adhesive.

16. Apply the specified grease to the bellows mounting position (fitting groove) of the tie rod.

Ebay User ID: reveleus1

: Silicone grease

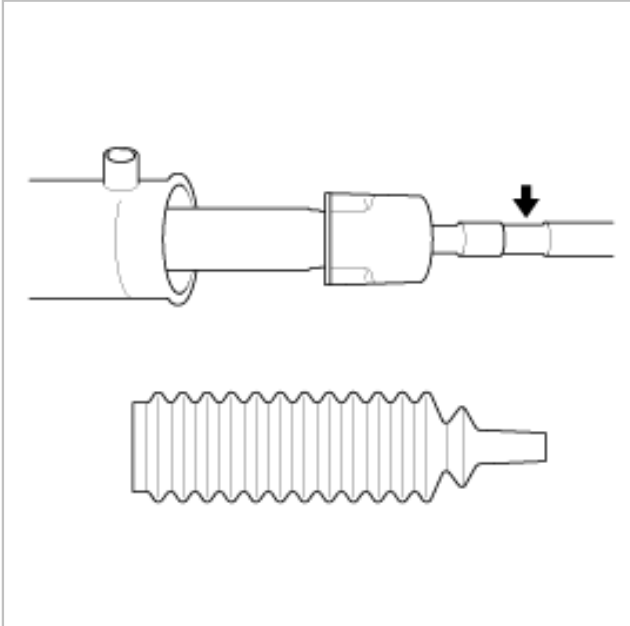

17. Install the new attaching band to the bellows.

NOTE

When the bellows are installed, a new band must be used.

18. Install the bellows in position, taking care not to twist it.

19. Fill the dust cover inner side and lip with the specified grease, and fix the dust cover in position with the clip ring attached in the groove of the tie rod end.

Recommended greas

A : POLY LUB GLY 801K or equivalent

B : SHOWA SUNLIGHT MB2 or equivalent

Dust cover inner side and lip : THREE BOND

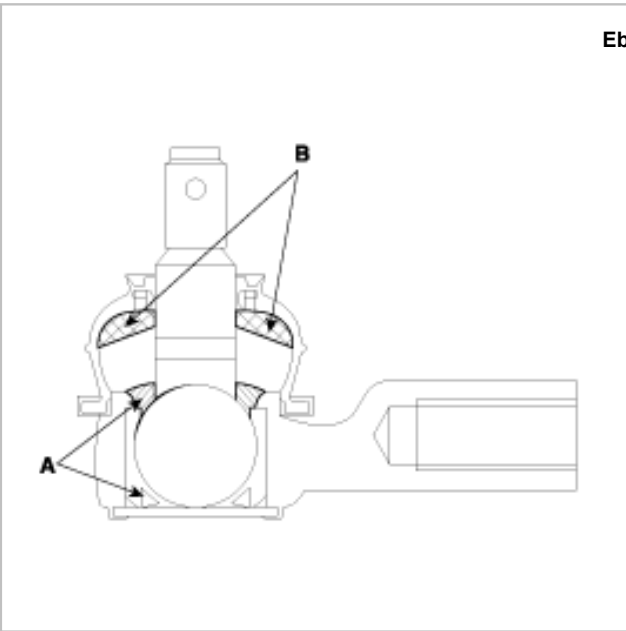

20. Install the tie rods so that the length of the left and right tie rods equals the standard value.

Standard value

Tie rod free length : 204.5mm

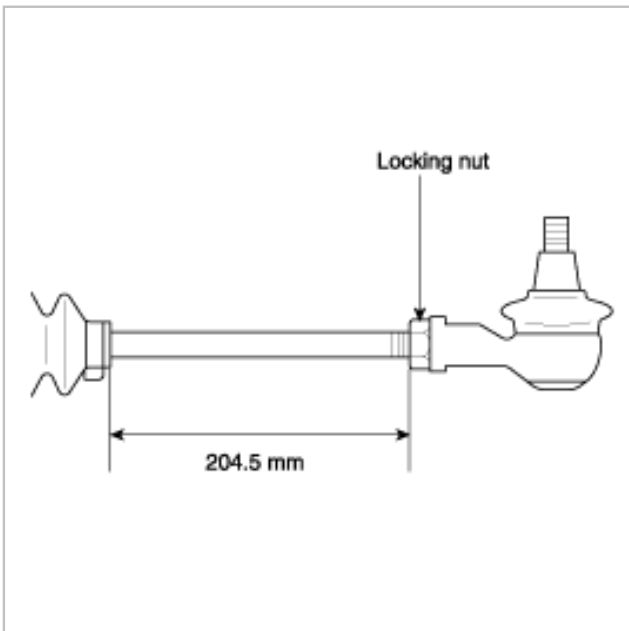

21. Check for total pinion preload.

INSPECTION AND ADJUSTMENT BEFORE DISASSEMBLY

CAUTION

Ebay User ID: reveleus1

When mounting the gear box in a vise, let the installation section of it be fixed to the jaws. If other section is fixed the gear box may be damaged.

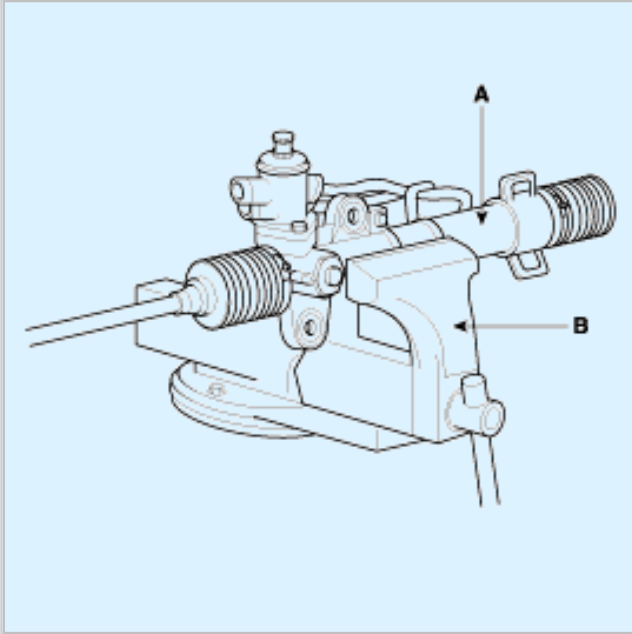
**TOTAL PINION PRELOAD**

1. Rotate the pinion gear for approximately 4 to 6 seconds for one rotation to measure the total pinion preload.

Standard value

Total pinion preload :

0.6~1.3 Nm (6~13 kg.cm, 0.4~1.0 lb.ft)

NOTE

Measure the pinion preload through the entire stroke of the rack.

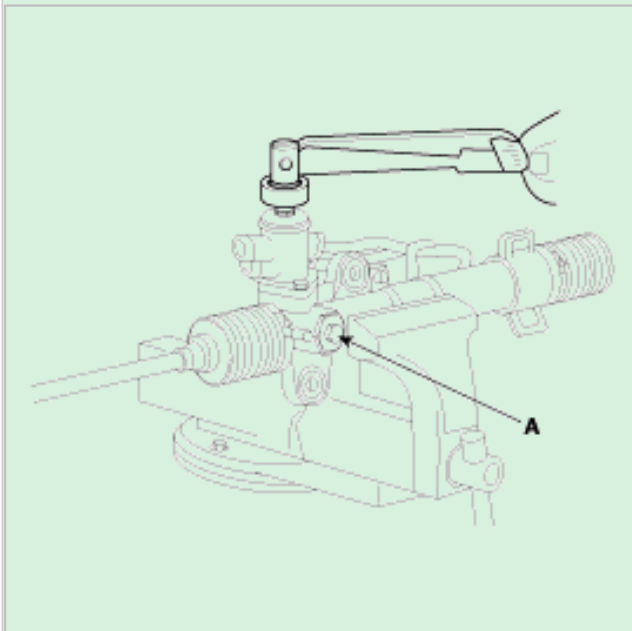

2. If the measured value is out of specifications, first adjust the yoke plug(A), then recheck the total pinion preload.
Ebay User ID: reveleus1
3. If you adjust the yoke plug but do not obtain the total pinion preload, check or replace the yoke plug components

TIE ROD SWING RESISTANCE

1. Rotate the tie rod severely ten times.
2. Measure the tie rod(A) swing resistance with a spring scale(B).

Standard value

Total rod swing resistance :

8-22 N (1.9-4.6 lb) [2-5 Nm (20-50 kg.cm, 17-43 lb.in)]

3. If the measured value exceeds the standard value, replace the tie rod assembly.

CAUTION

Even if the measured value is below the standard value, the tie rod that swings smoothly without excessive play may be used. If the measured value is below 4.3 N (0.9 lb) [100 Ncm (8.7 lb.in.)], replace the tie rod.

BELLOWS INSPECTION

1. Inspect the bellows for damage or deterioration.
2. Make sure the bellows are secured in the correct position.
3. If the bellows are defective, replace them with new ones.

INSPECTION AND ADJUSTMENT BEFORE DISASSEMBLY

CAUTION

When mounting the gear box in a vise, let the installation section of it be fixed to the jaws. If other section is fixed the gear box may be damaged.

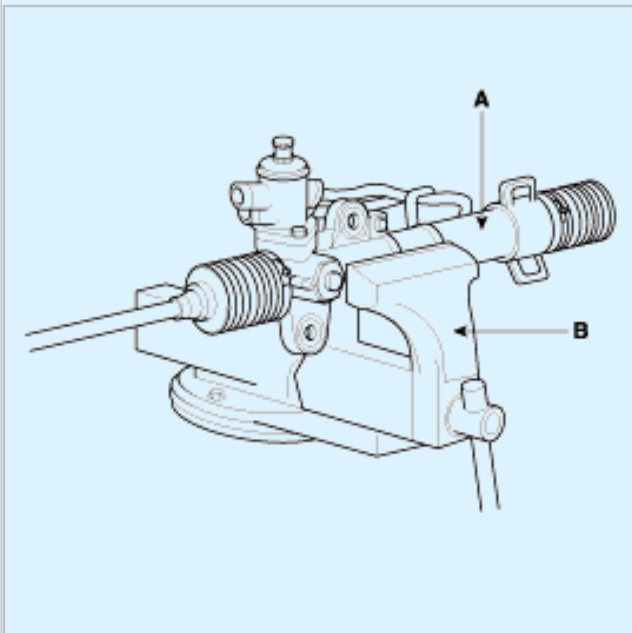

TOTAL PINION PRELOAD

1. Rotate the pinion gear for approximately 4 to 6 seconds for one rotation to measure the total pinion preload.

Ebay User ID: reveleus1

Standard value

Total pinion preload :

0.6~1.3 Nm (6~13 kg.cm, 0.4~1.0 lb.ft)

NOTE

Measure the pinion preload through the entire stroke of the rack.

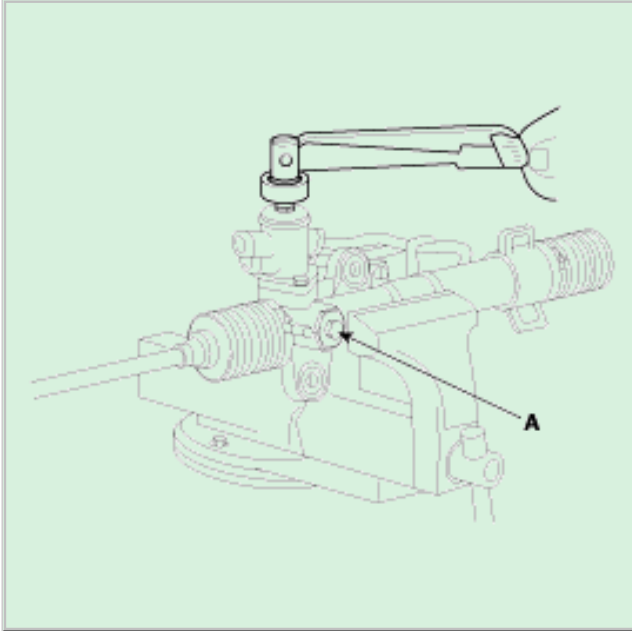

2. If the measured value is out of specifications, first adjust the yoke plug(A), then recheck the total pinion preload.
3. If you adjust the yoke plug but do not obtain the total pinion preload, check or replace the yoke plug components

TIE ROD SWING RESISTANCE

1. Rotate the tie rod severely ten times.
2. Measure the tie rod(A) swing resistance with a spring scale(B).

Standard value

Total rod swing resistance :

8-22 N (1.9-4.6 lb) [2-5 Nm (20-50 kg.cm, 17-43 lb.in.)]

3. If the measured value exceeds the standard value, replace the tie rod assembly.

CAUTION

Even if the measured value is below the standard value, the tie rod that swings smoothly without excessive play may be used. If the measured value is below 4.3 N (0.9 lb) [100 Ncm (8.7 lb.in.)], replace the tie rod.

BELLOWS INSPECTION

1. Inspect the bellows for damage or deterioration.

Purchased
from Ebay seller
Reveleus1

Thank-you for purchasing from me, it
is much appreciated.

To contact me please email
suzlever@gmail.com

2. Make sure the bellows are secured in the correct position.
3. If the bellows are defective, replace them with new ones.

Ebay User ID: reveleus1

COMPONENTS

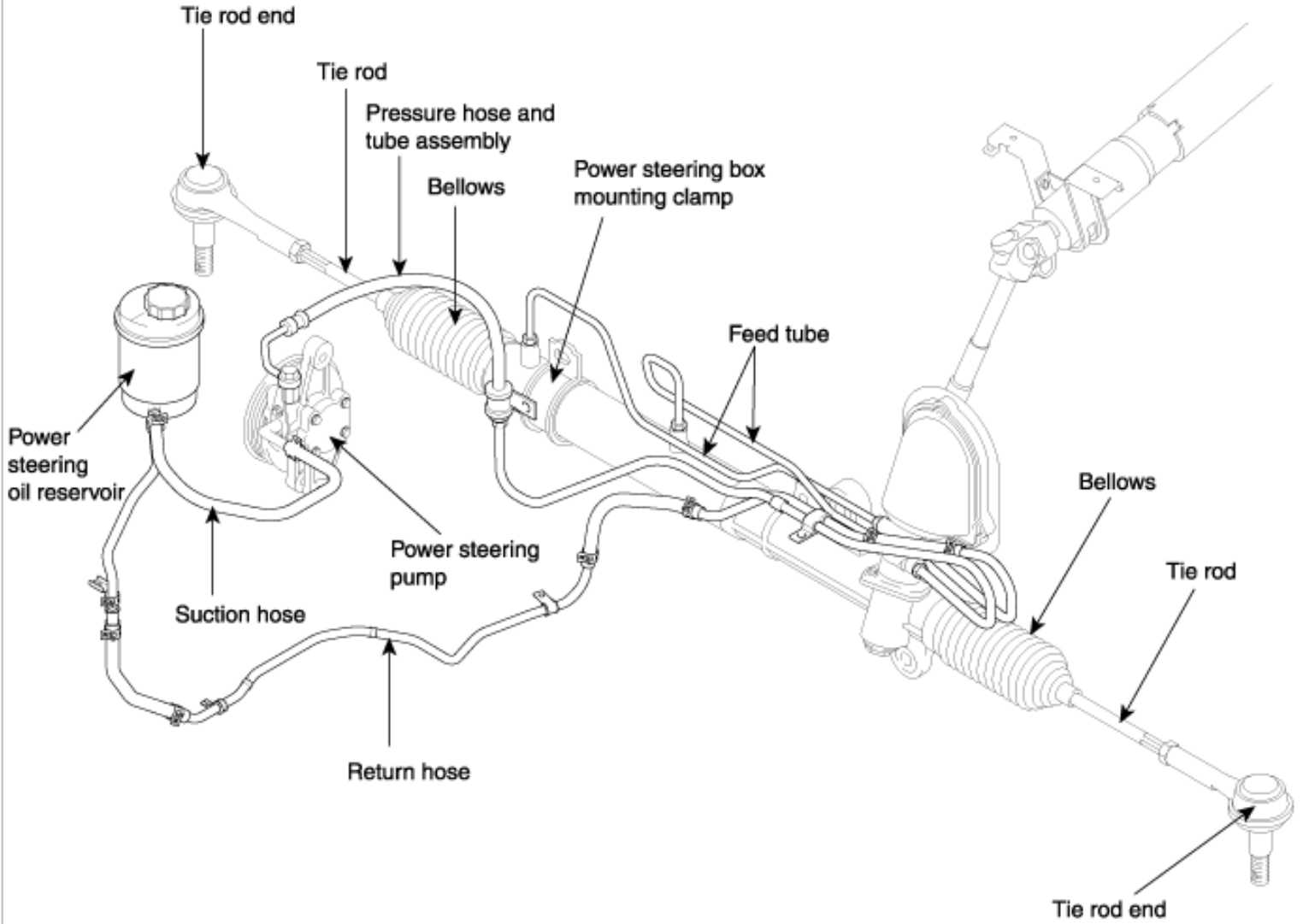

REMOVAL AND INSTALLATION

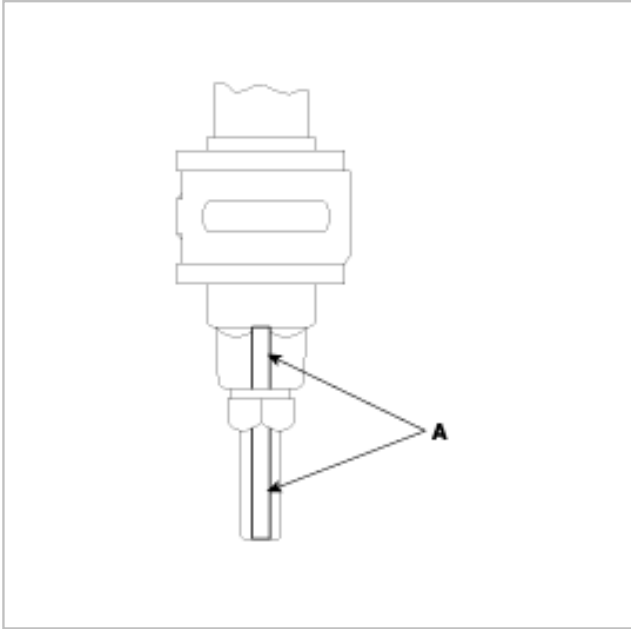

PRESSURE HOSE AND TUBE

1. Remove the air intake hose(A) assembly.

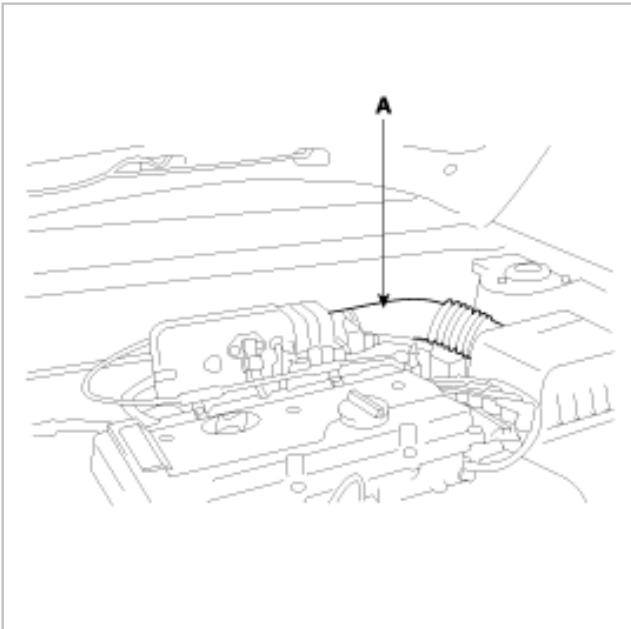

2. Remove the pressure hose mounting clamp.
3. Disconnect the pressure tube fitting at the gear box side.

4. Lift up the vehicle and remove the mounting clamp which is holding both the pressure tube and the return tube (A).
Ebay User ID: reveleus1

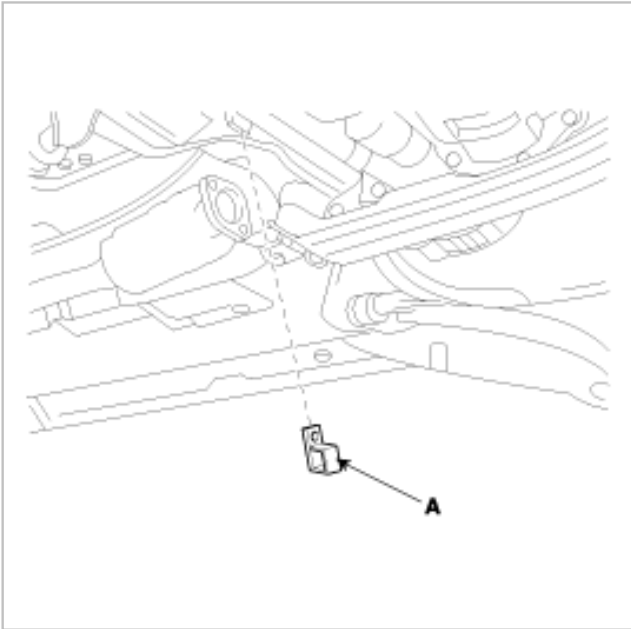

5. Lower the vehicle and remove the connector(A) (24mm).

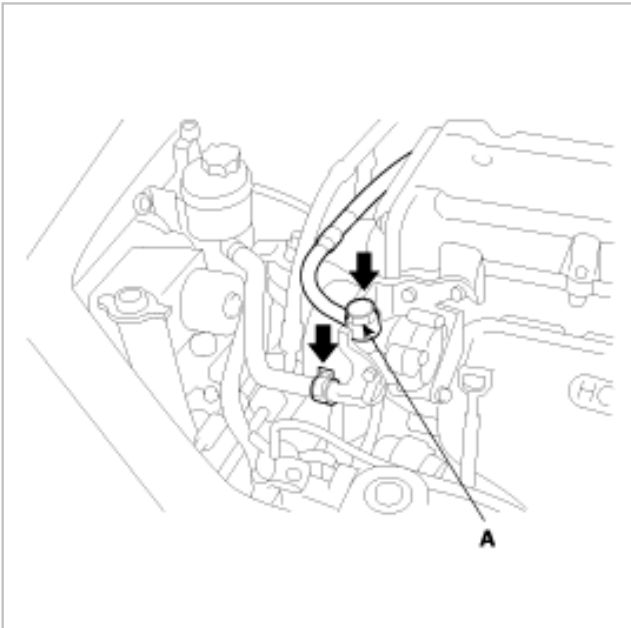

6. Remove the pressure hose and tube assembly.

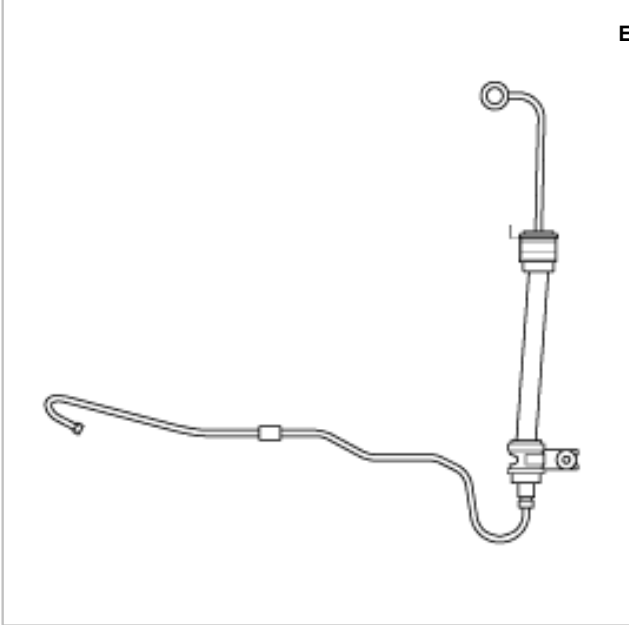

7. Installation is the reverse of removal.

NOTE

1. Install the pressure hose and tube so that they are not twisted and they do not come in contact with any other parts.
2. After installation, air bleed the system.

RETURN TUBE AND HOSE

1. Detach the power steering fluid reservoir(A) from its mounting bracket.

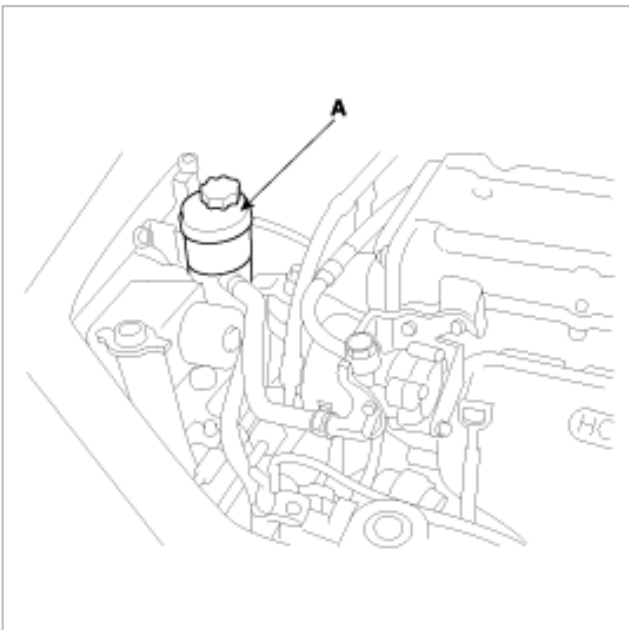

2. Remove the return tube and hose mounting clamps.

3. Remove the air intake hose assembly(A).

Ebay User ID: reveleus1

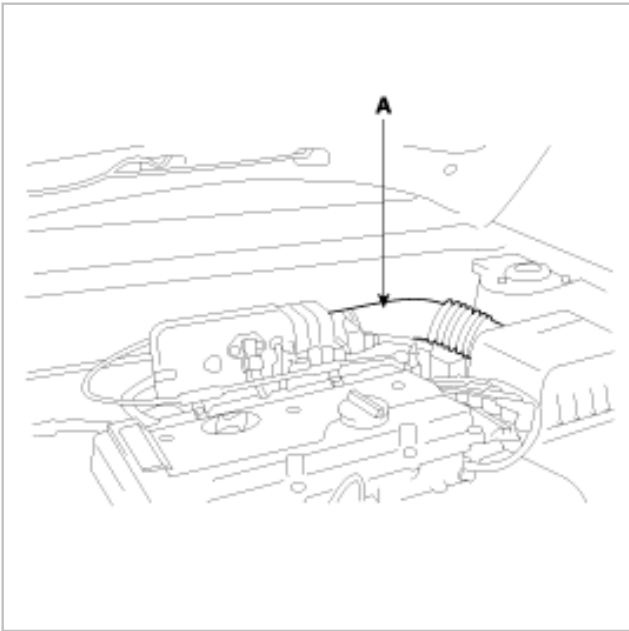

4. Disconnect the pressure tube and the return tube fittings at the gear box assembly.

5. Raise the vehicle and remove the mounting clamp that is holding both the pressure tube and the return tube (A).

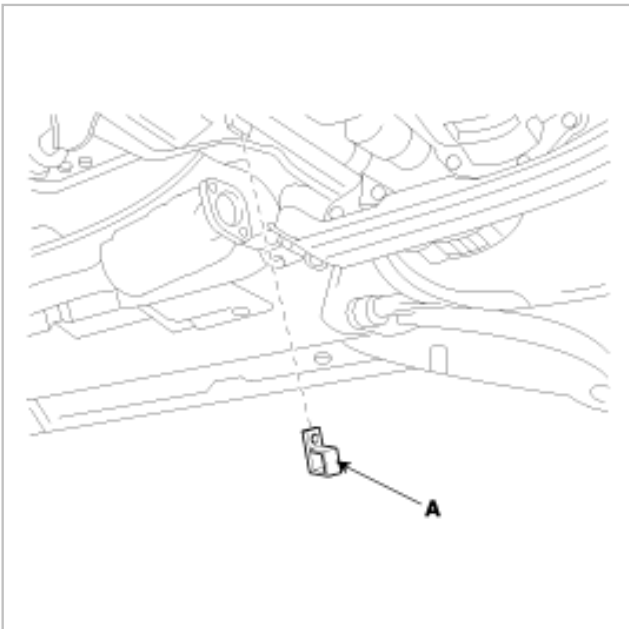

6. Lower the vehicle and disconnect the clamp holding the return tube and hoses.

7. Remove the return tube and hose assembly(A)

Ebay User ID: reveleus1

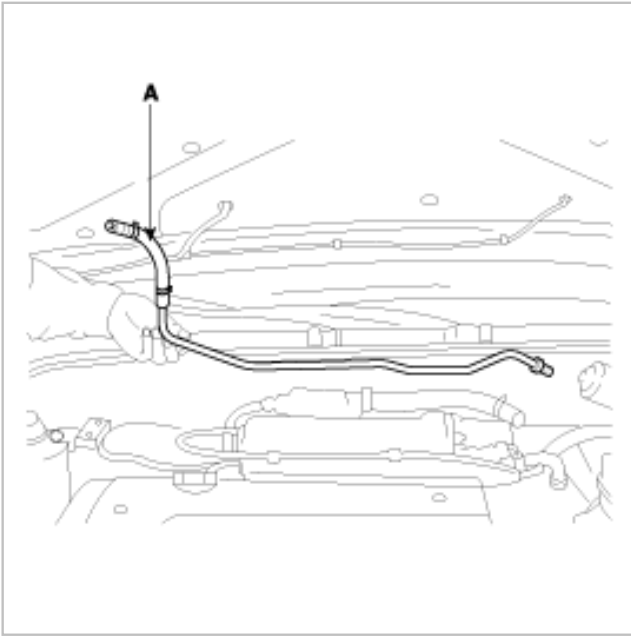

8. Installation is the reverse of removal.

NOTE

1. Install the return tube and hoses so that they are not twisted and it does not come in contact with any other parts.
2. After installation, air bleed the system.

INSPECTION

1. Twisting the hose by hand, check for cracks.
2. Check that the hose does not contact other components

HOW TO FILL WITH POWER STEERING FLUID

1. Fill the power steering reservoir with power steering fluid to the "Max." position.
2. Lift the front wheels with a jack and turn the steering wheel fully to the left and right, at the speed of 13rpm and 5~6times while drivingthe pulley only by operating the start motor.
3. Start the engine, let it idle and turn the steering wheel fully left and right several times until bubbles disappear from the power steering reservoir.
4. If the oil color does not become milk-white and the oil level is constant at the "MAX" position, fluid level is O.K.

CAUTION

If the oil level changes when turning the steering wheel, and the oil overflows when stopping the engine, it shows that air bleeding wasn't performed perfectly. As it can cause noise and early damage, you must repeat the aboveprocedures.

COMPONENTS

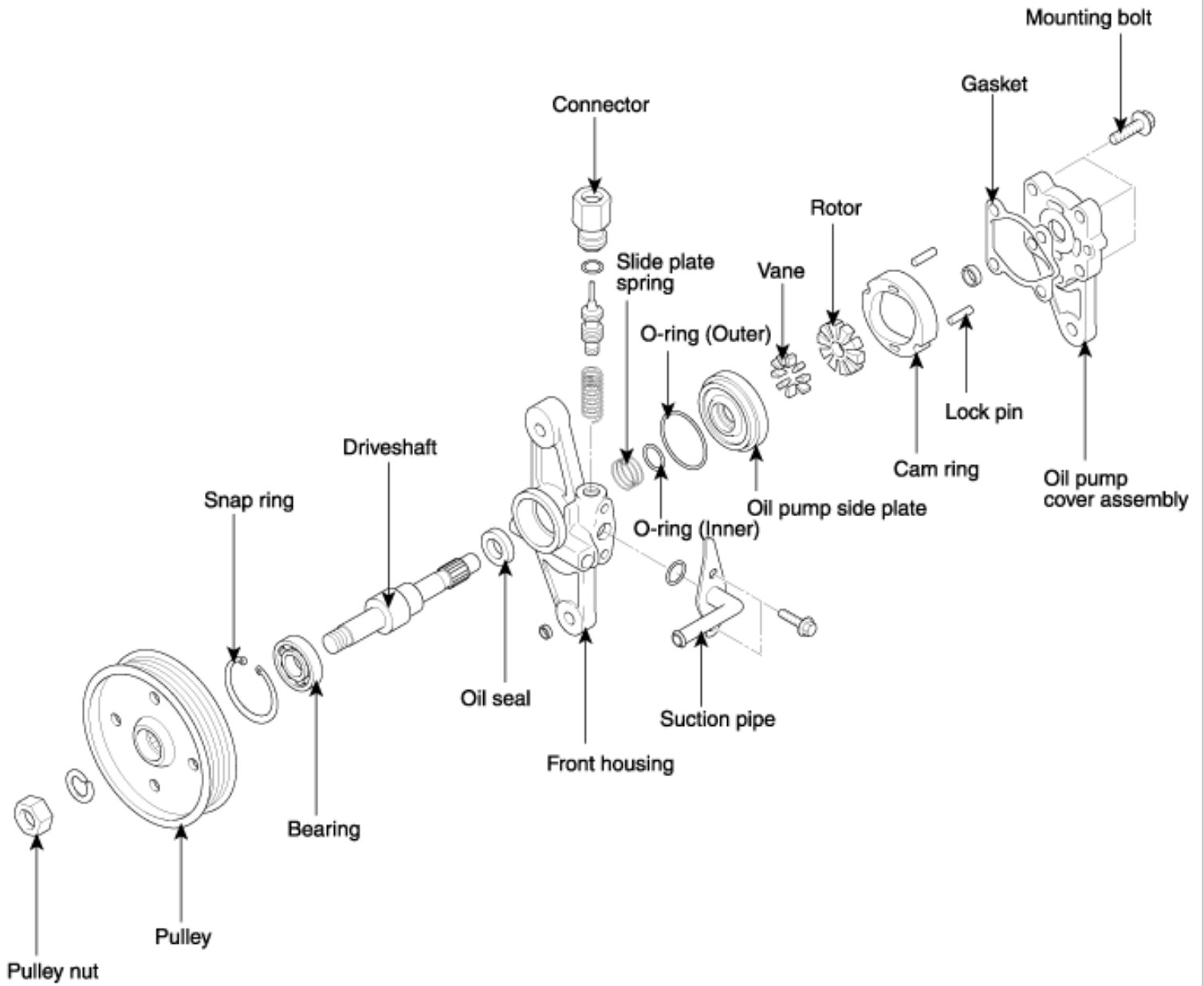

REMOVAL

1. Remove the pressure hose(A) from the oil pump(B).
2. Disconnect the suction hose(C) from the suction connector(D) and drain the fluid into a container.

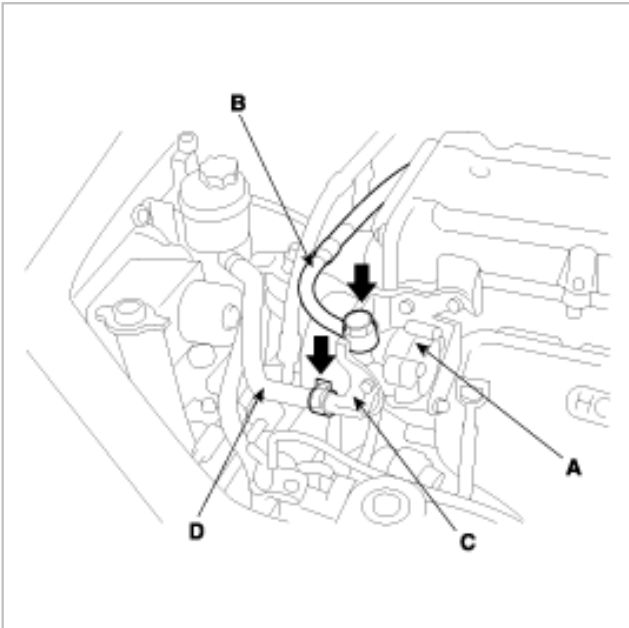

3. Loosen the oil pump mounting bolts to remove the V-belt.
4. Loosen the tension adjusting bolt(A).

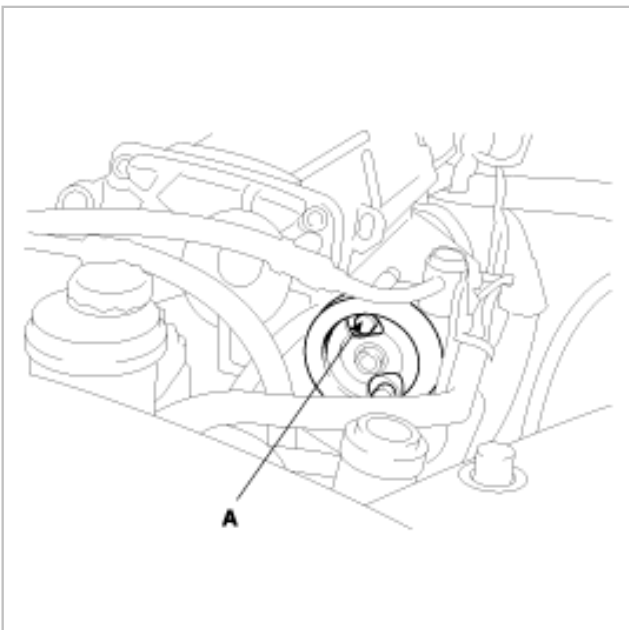

5. Remove the power steering drive belt(A) from the power steering oil pump pulley.

Ebay User ID: reveleus1

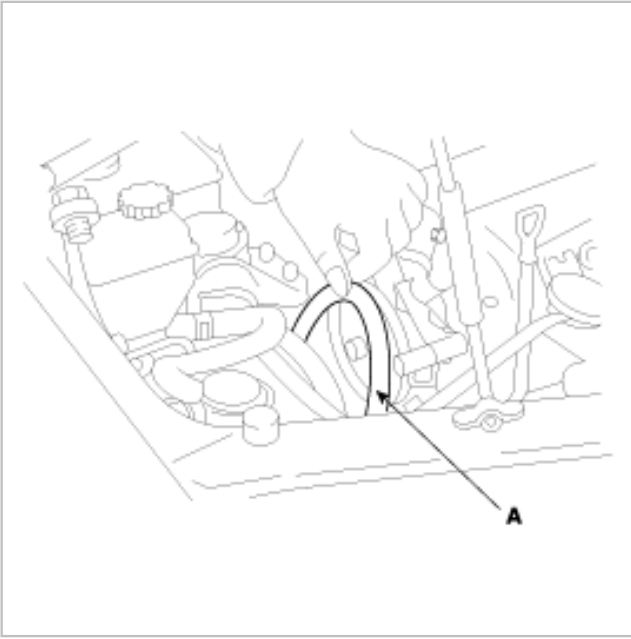

6. Remove the power steering oil pump mounting bolts and the tension adjusting bolt.
7. Remove the power steering oil pump assembly.

NOTE

Be careful not to drip fluid from the power steering oil pump.

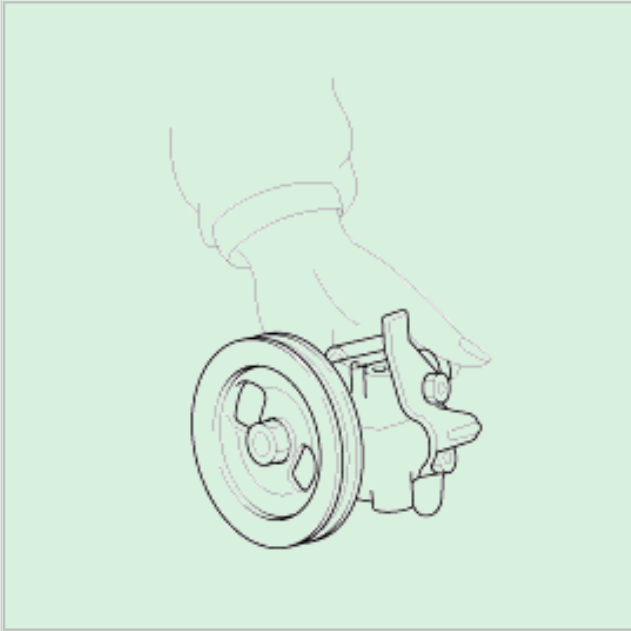

8. Remove the power steering oil pump mounting bracket(A).

Ebay User ID: reveleus1

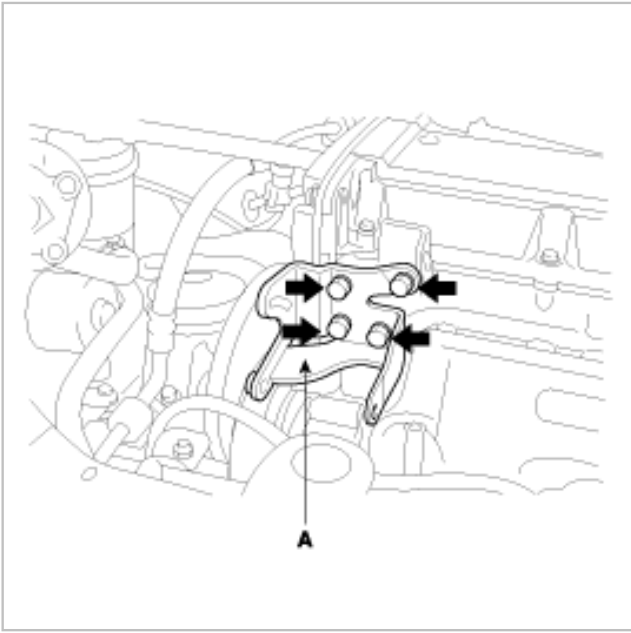

INSTALLATION

1. After installing the oil pump to the oil pump bracket, install the "V" belt and tighten the bolt adjusting tension to the specified torque.

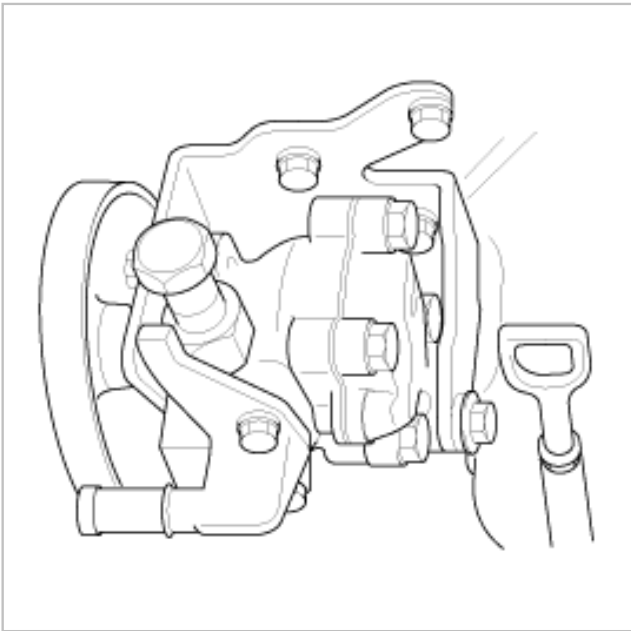

2. Install the suction hose.

CAUTION

Install the pressure hose to the oil pump.

3. Install the pressure hose(A) to the oil pump(B). Ebay User ID: reveleus1

NOTE

Install the pressure hose being careful so that it does not twist and come in contact with other components.

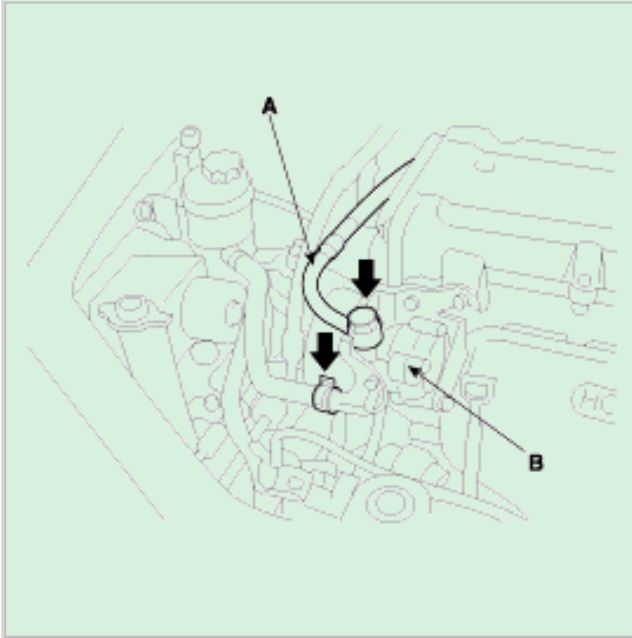

4. Add power steering fluid (PSF-3).
5. Air bleed the system.
6. Check the oil pump pressure.

DISASSEMBLY

1. Remove two bolts(A) from the oil pump body(B), and then remove the suction pipe(C) and O-ring.

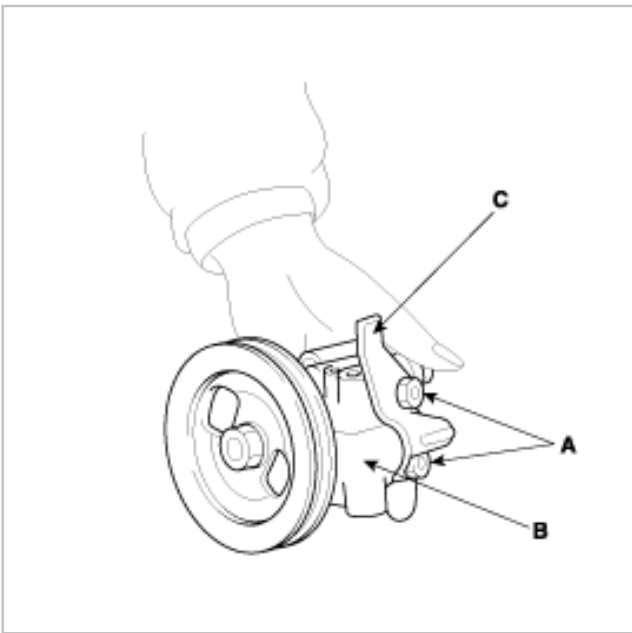

2. Loosen the four bolts and remove the oil pump cover assembly.
3. Remove the cam ring.
4. Remove the rotor and vanes.

5. Remove the oil pump side plate.

Ebay User ID: reveleus1

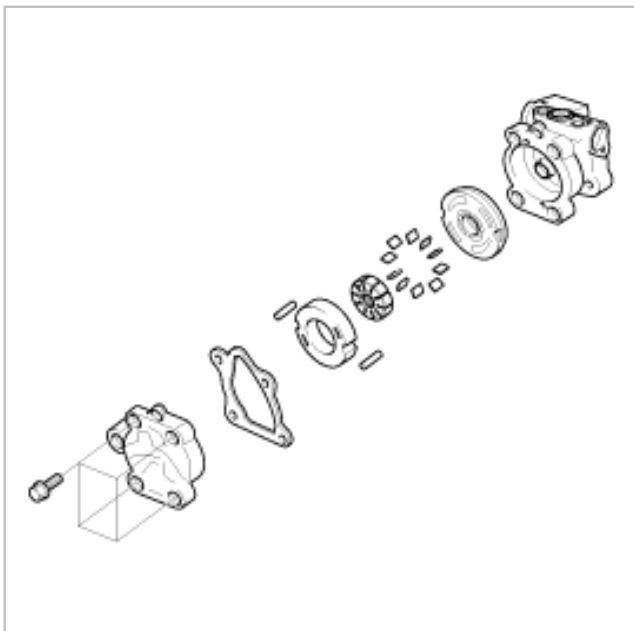

6. Remove the inner(A) and outer O-ring(B).

7. Remove the side plate spring(C).

NOTE

When assembling, use a new gasket and O-ring.

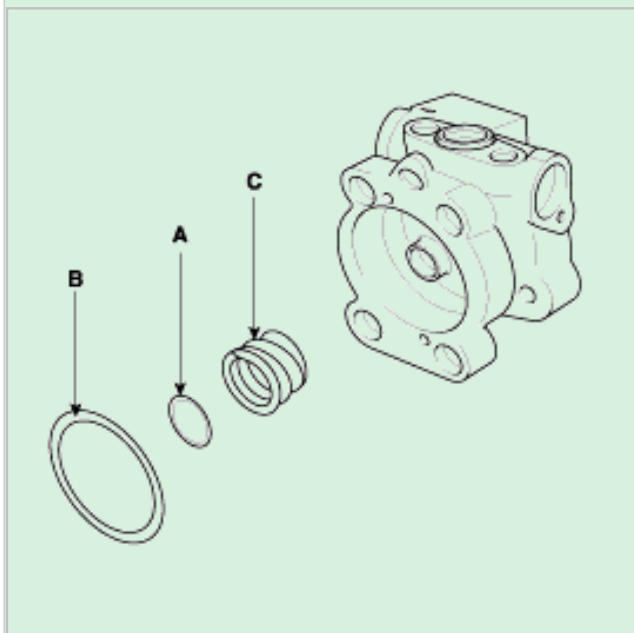

8. Mount the pulley in a vise and remove the pulley nut and the spring washer. Ebay User ID: reveleus1

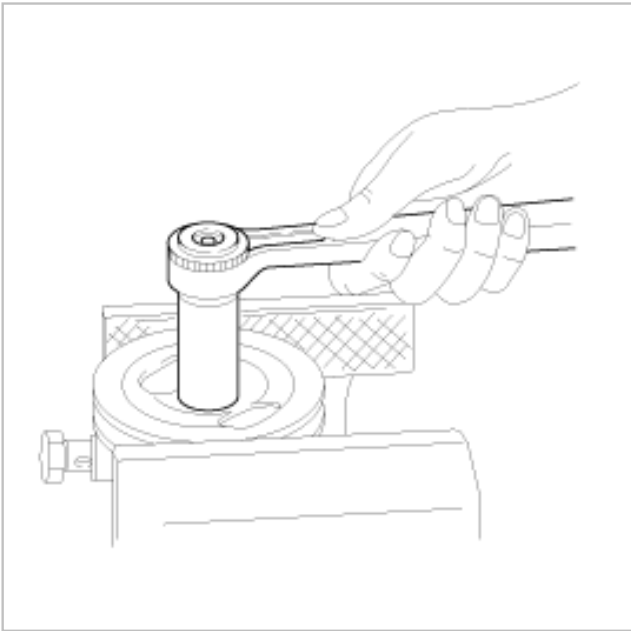

9. Pull the pulley out.

10. After removing the snap ring(A) of the shaft with snap ring pliers, remove the dust spacer(B).

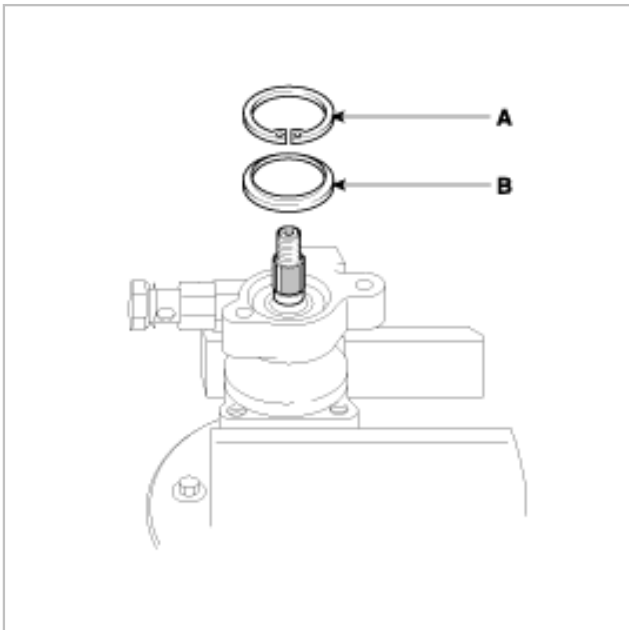

11. Tap the rotor side of the shaft slightly with a plastic hammer(A) to remove the shaft(B).

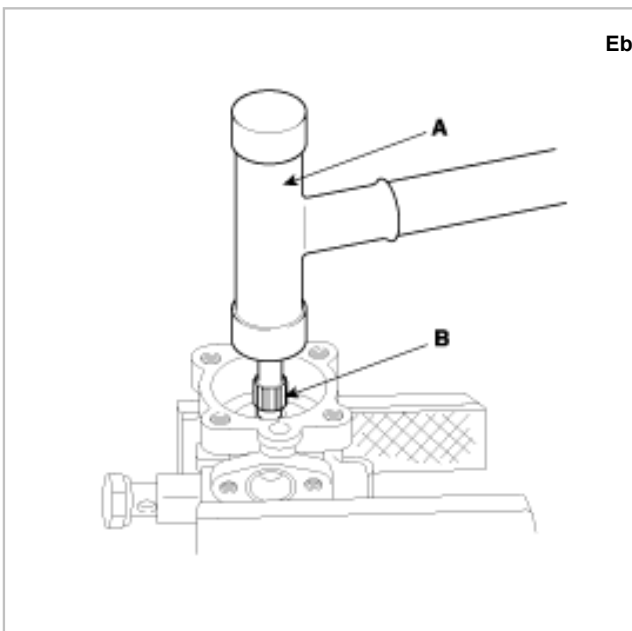

12. Remove the oil seal(A) from the oil pump body(B).

NOTE

When assembling, use a new oil seal.

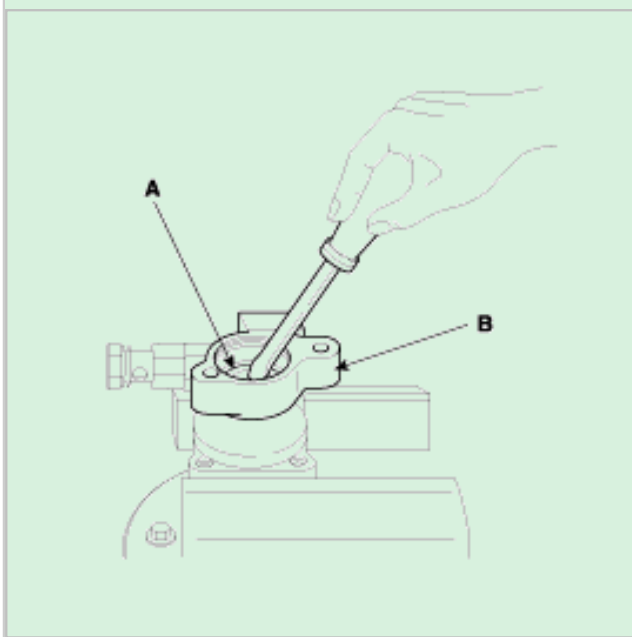

13. Remove the connector from the oil pump body, and take out the flow control valve and the flow control spring.

14. Remove the O-ring from the connector.

Ebay User ID: reveleus1

CAUTION

Do not disassemble the flow control valve.

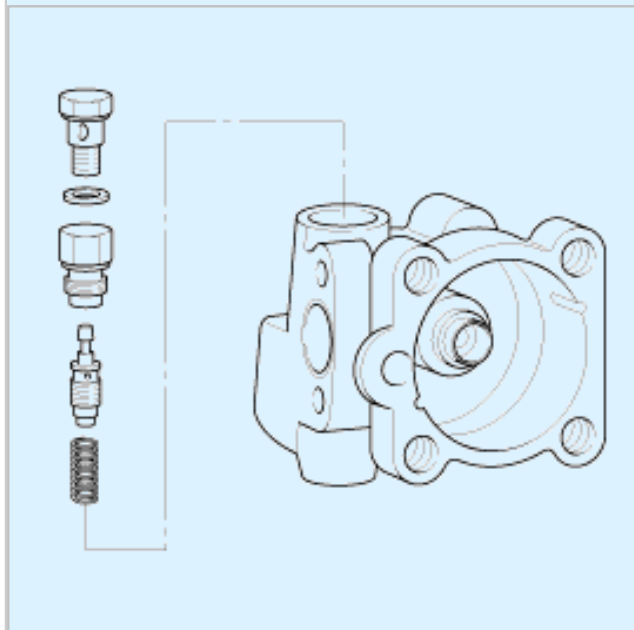

INSPECTION

1. Check the free length of the flow control spring.

Free length of the flow control spring : 36.5mm

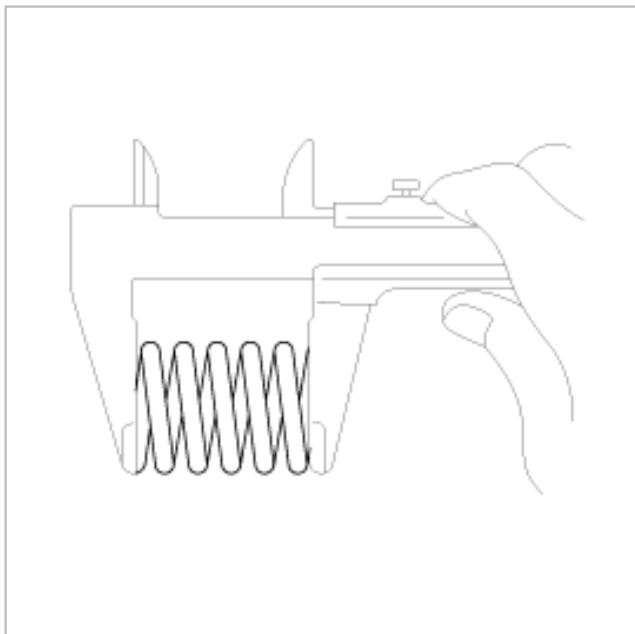

2. Check that the flow control valve is not bent.

3. Check the shaft for wear and damage.

4. Check the V-belt for wear and deterioration.

5. Check the grooves of the rotor and vanes for stratified abrasion.

6. Check the contact surface of the cam ring and vanes for stratified abrasion.

7. Check vanes for damage.

Ebay User ID: reveleus1

8. Check that there is no striped wear in the side plate or contacting part between the shaft and the pump cover surface.

REASSEMBLY

1. Install the flow control spring, the flow control valve and the connector in to the pump body.

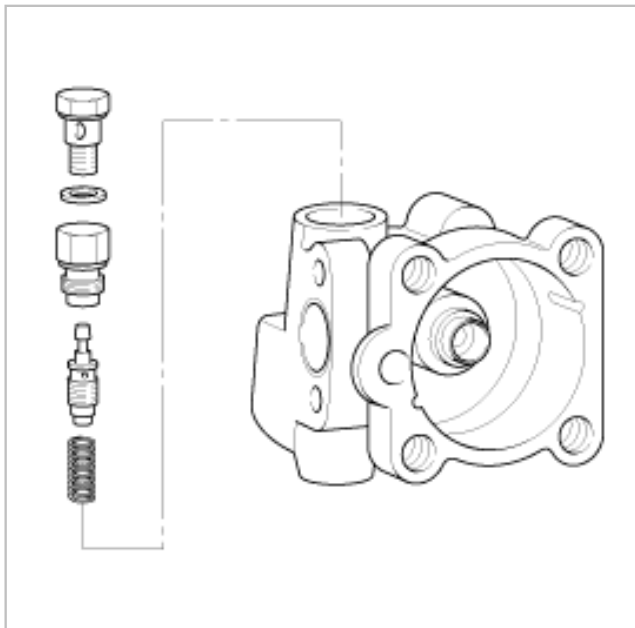

2. Install the oil seal in the pump body by using the special tool(09222-32100).

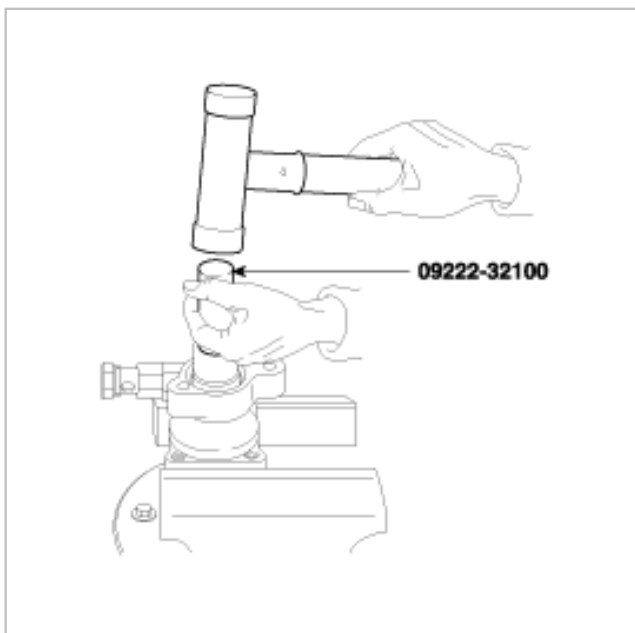

3. After inserting the shaft assembly(A) into the pump body, install the dust spacer (B) and snap ring(C).

Ebay User ID: reveleus1

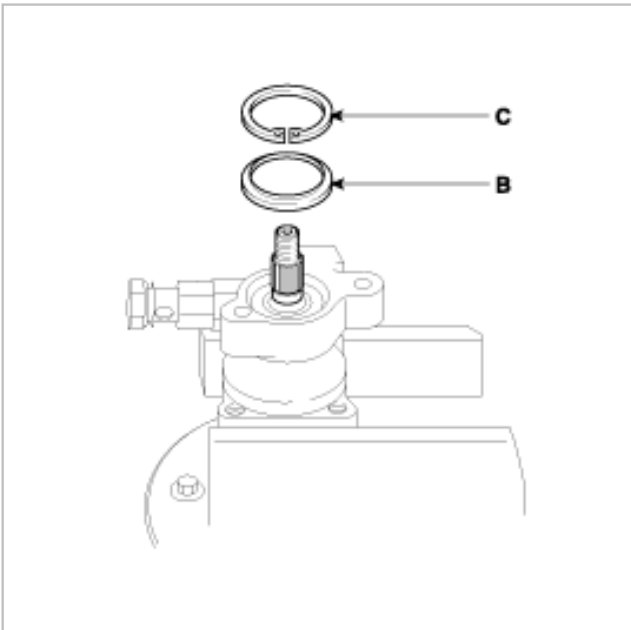
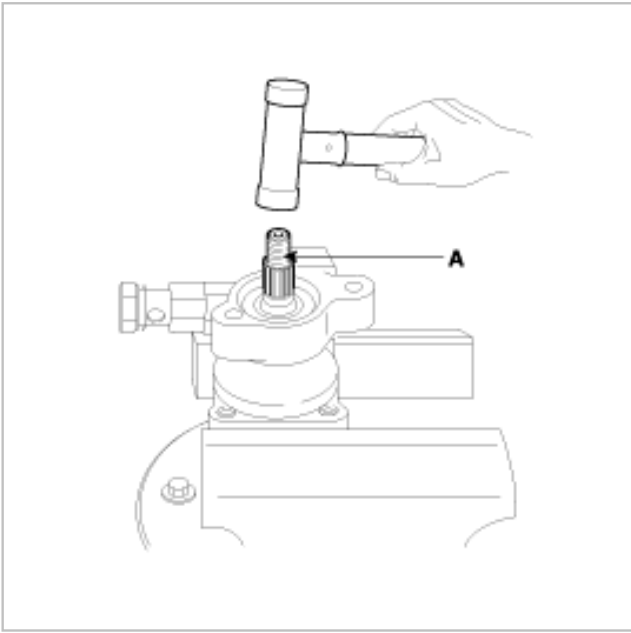

4. Install the pump pulley(A).

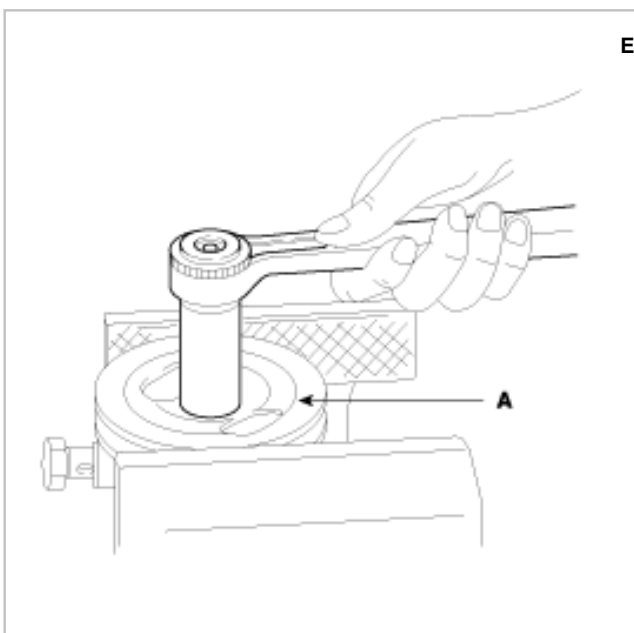

5. Install the spring(A) and inner O-ring(B).

6. Insert the outer O-ring in the oil pump side plate and then install it in the pump body.

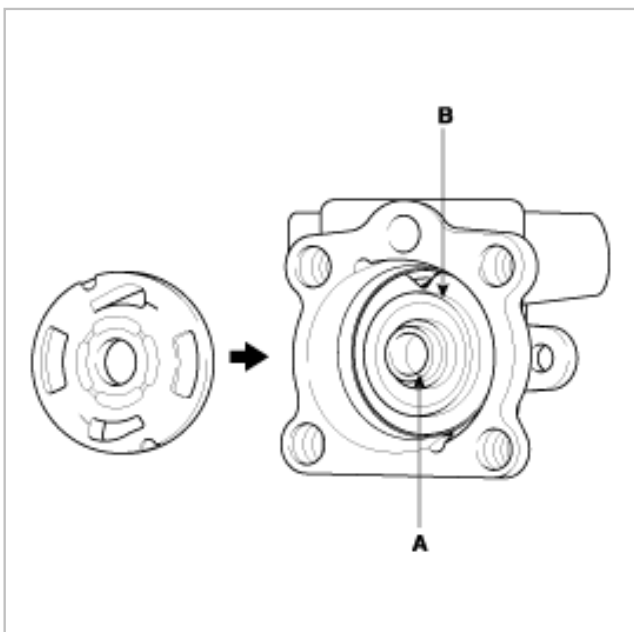

7. After inserting the lock pin into the groove of the front housing, install the cam ring attending to the direction.

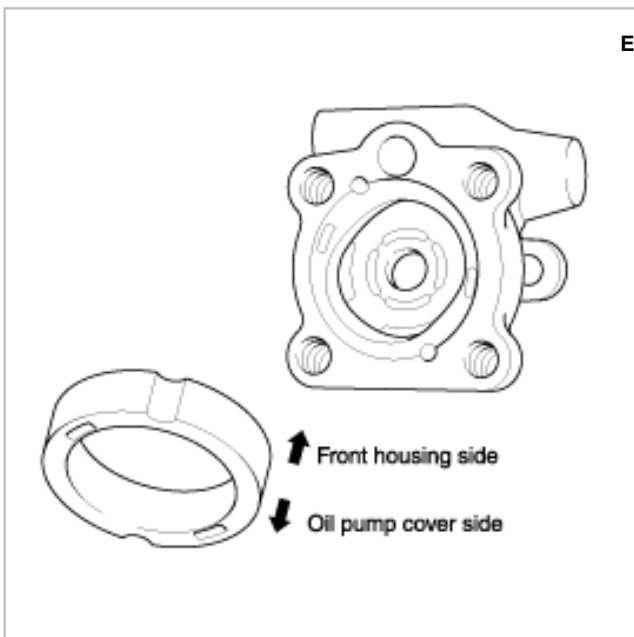

8. Install the rotor.

9. Install vanes(A) so that the rounded edges face outward.

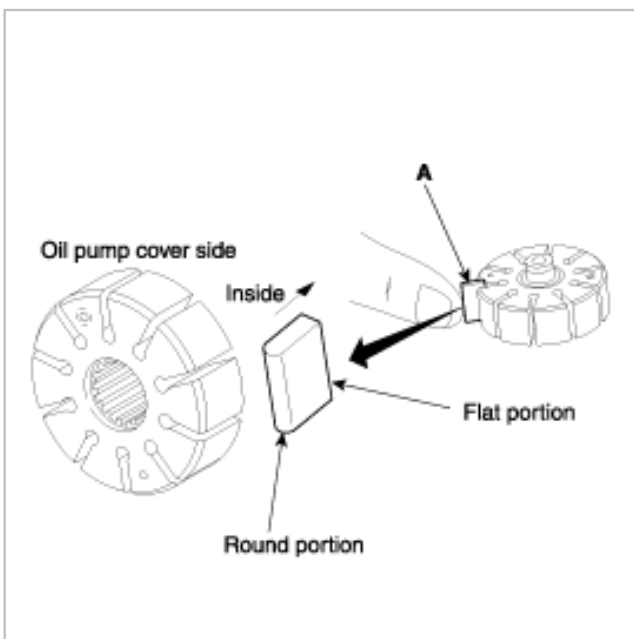



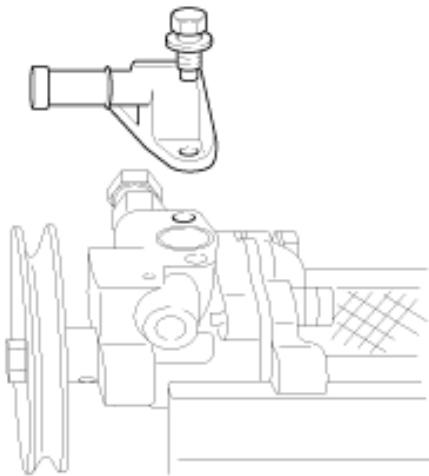

10. Install the gasket and oil pump cover assembly.

11. Install the suction pipe and O-ring.

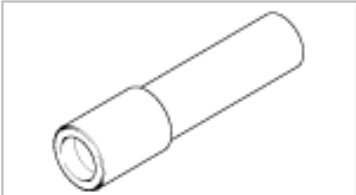
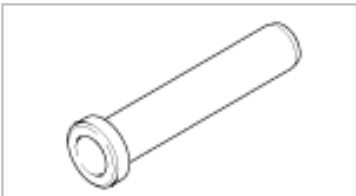
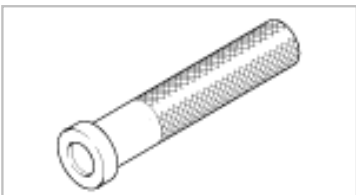
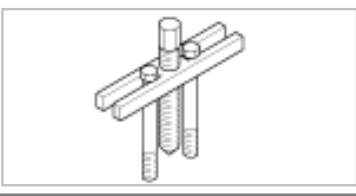

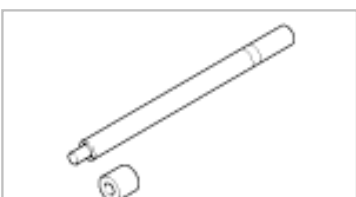
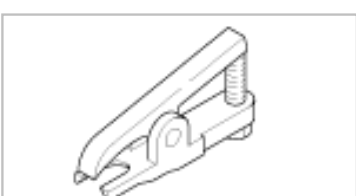
SPECIAL TOOLS

Tool (Number and name)	Illustration	Use
09222-32100 Valve stem oil seal installer		Installing the pinion gear bearing
09432-21600 Bearing installer		Installing the pinion gear bearing
09434-14200 Counter shaft bearing installer		Installing the gear box oil seal.
09561-11002 Steering wheel puller		Removing the steering wheel.
09565-11100 Preload socket		Measuring the mainshaft preload.
09555-21000 Bar		Removing & installing the oil seal.
09568-34000 Ball joint puller		Separating the tie rod end ball joint.

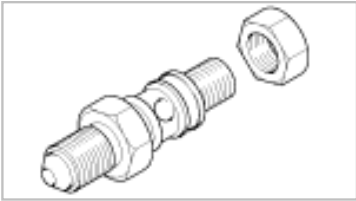
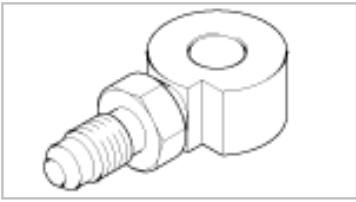
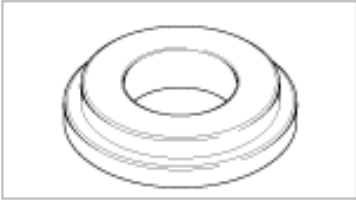
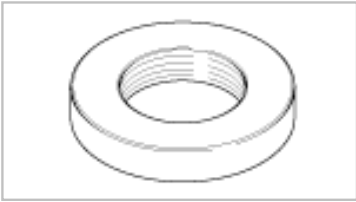
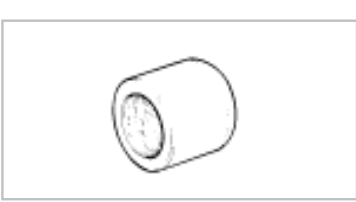
<p>09572-21000 Oil pressure gauge</p>	<p>Ebay User ID: reveleus1</p> 	<p>Measuring the power steering oil pressure (use with 09572-21200, 09572-22100)</p>
<p>09572-21200 Oil pressure gauge adapter</p>		<p>Measuring the power steering oil pressure (use with 09572-21000, 09572-22100)</p>
<p>09572-22100 Oil pressure gauge adapter</p>		<p>Measuring the power steering oil pressure (use with 09572-21000, 09572-21200)</p>
<p>09573-21000 Oil seal installer gauge</p>		<p>Installing the back-up washer and oil seal. (use with 09573-21100, 09573-21200, 09517-11000, 09555-21000)</p>
<p>09573-21100 Oil seal installer</p>		<p>Installing the back-up washer and oil seal. (use with 09573-21000, 09573-21200, 09555-21000)</p>
<p>09573-21200 Oil seal guide</p>		<ol style="list-style-type: none"> 1. Removing the gear box oil seal and back washer (use with 09573-21000) 2. Installing the gear box oil seal and back washer (use with 09555-21000, 09573-21000)



SPECIFICATIONS

POWER STEERING

Items	Specifications
Shaft and joint type	Cross joint, tilt column with pop-up weight
Steering gear type	Rack and pinion
Rack stroke	144 ± 1 mm (lock to lock : 3.15 turns)
Power steering pump type	Vane type
Oil pump displacement	9.6cm ³ /rev. MAX. (0.59 in ³ /rev. MAX.)

SERVICE STANDARD

POWER STEERING

Items	Specifications
Steering wheel free play	0~30mm (0~1.1 in.)
Steering angle	40°1' ± 2°
Inner wheel	33°45'
Outer wheel	2° or less
Difference between LH and RH	29N (3.0kg, 6.5lbs) or less
Stationary steering effort	6~9mm
Belt deflection [under 98N (10kg, 22lb) force]	8.3~8.8 MPa (85~90 kg/cm ² , 1209~1280 psi)
Oil pump relief pressure	0.6~1.3 Nm (6~13 kg.cm, 5.2~11.3 lb.in.)
Total pinion preload	2~5 Nm (20~50 kg.cm, 1.4~3.6 lb.ft)
Tie rod swing resistance	

TIGHTENING TORQUE

Item	Nm	kg·cm	lb·ft
Steering wheel and shaft (with Airbag)	35~45	350~450	26~33
Steering column and shaft assembly mounting bracket	13~18	130~180	9.6~13.3
Steering shaft and joint	15~20	150~200	11~15
Joint to gear box	15~20	150~200	11~15
Dust cover mounting bolt	17~26	170~260	12.5~19.2
Gear box to body	60~80	600~800	44~59
Tie rod end lock nut	50~55	500~550	36.9~40.6
Tie rod end ball joint slotted nut	24~34	240~340	17.7~25
Yoke plug lock nut	50~70	500~700	37~52
Tie rod to rack	80~100	800~1000	59~74
Valve body housing to rack housing assembly	20~30	200~300	14.8~30.7
Pressure and return tube to gear box	12~18	120~180	9~13

Pinion and valve assembly to self-locking nut	Ebay User ID: reveleus1	20~30	200~300	15~22
Feed tube		12~18	120~180	9~13
Oil pump to mounting bracket		35~50	350~500	25.8~36.9
Oil pump bracket to engine		35~50	350~500	25.8~36.9
Pressure hose to oil pump		55~65	550~650	40.6~47.9
Oil reservoir mounting bolt		4~6	40~60	3.0~44

LUBRICANTS

Item	Recommended lubricant	Quantity
Horn contact ring of steering wheel	CENTOPLX278 (KLUBER KOREA)	As required
Bearing of steering shaft	ALVANIA #2 OR #3 (KEUK DONG SHELL, KOREA)	As required
Ball joint of tie rod end	SHOWA SUNLIGHT MB-2 OR equivalent	As required
Steering gear housing	ONE-LUBER RP GREASE (KYODOYUSHI, JAPAN)	As required
Inner ball joint of gear box	LONG TIME PD2 (OPTIMOL, GERMAN)	As required
Contact area of gear box bellows & tie rod	SILICON GREASE (SPEC NO : MS511-41)	As required
Power steering fluid	PSF-3	0.75~0.8 liter (0.79~0.84 qts.)

COMPONENTS

WITH SRS AIRBAG

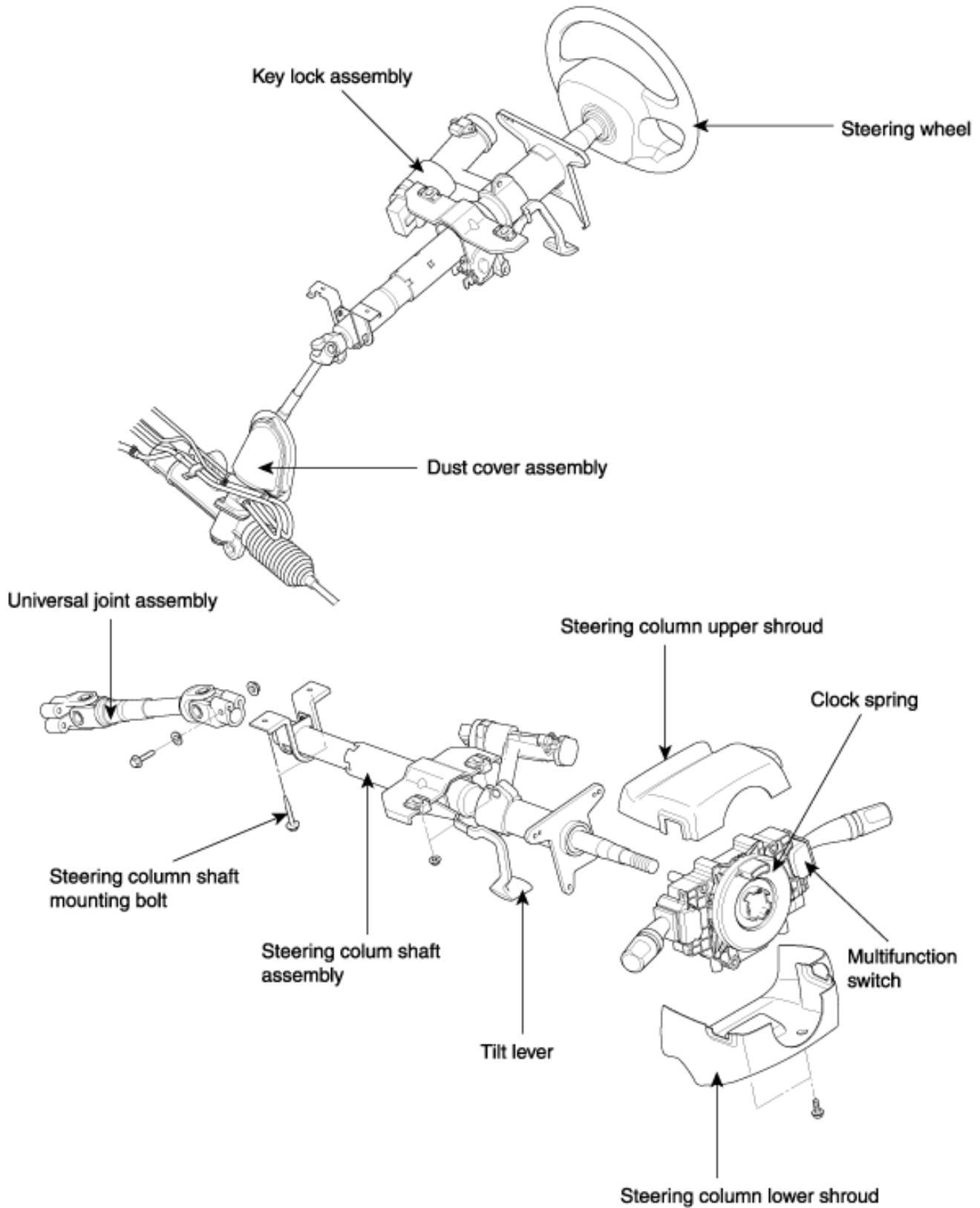

REMOVAL

1. Disconnect the negative (-) terminal(A) from the battery.

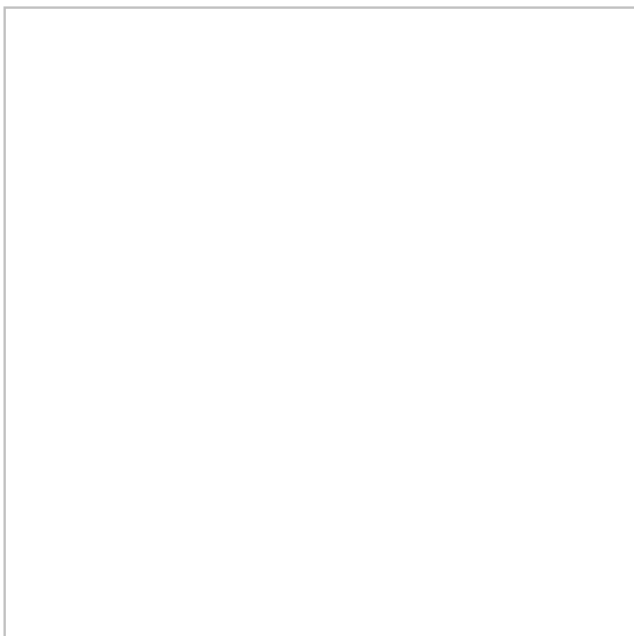

2. Take away the bolts (A) in the illustration, and then remove the driver's airbag module(B).

NOTE

For the vehicles not equipped with SRS airbag, remove the horn cover assembly.

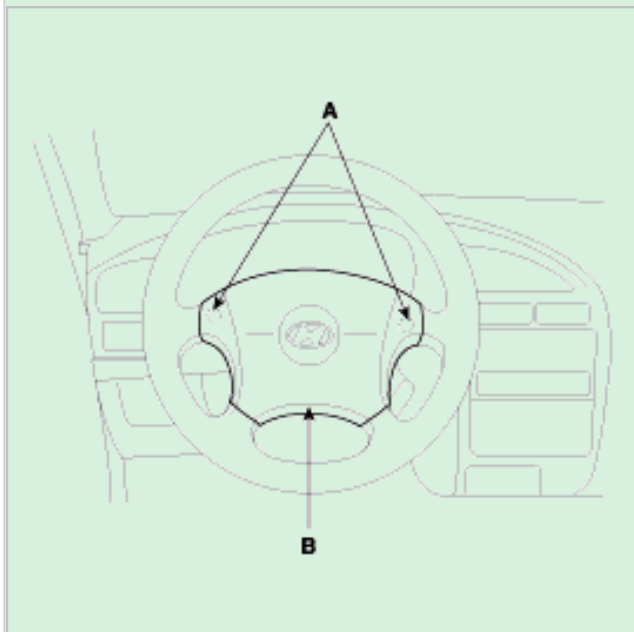

3. Remove the steering wheel lock nut(A).

Ebay User ID: reveleus1

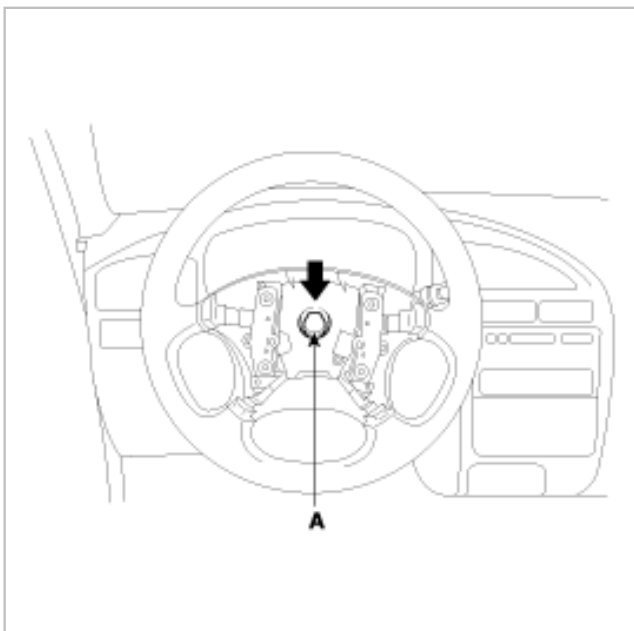

4. After aligning the marks on the steering shaft and wheel(A), remove the steering wheel using the special tool (09561-11002).

NOTE

Do not hammer on the steering wheel to remove it: it may damage the steering column.

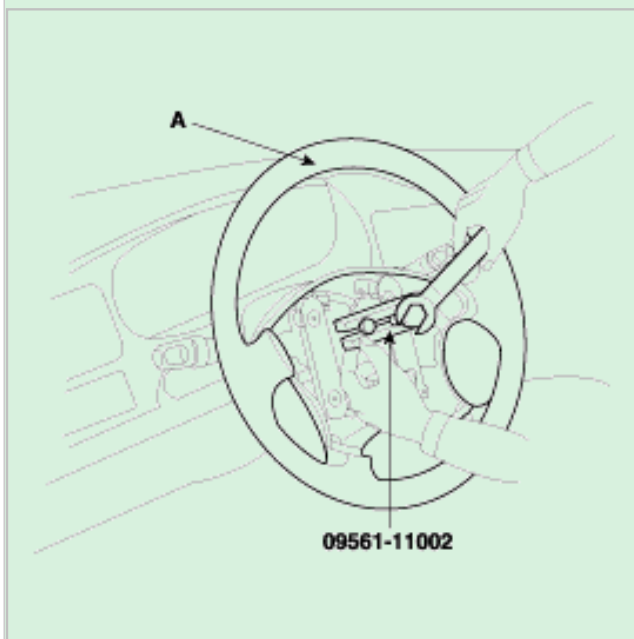

5. Remove the steering column upper(A) and lower shrouds(B).
Ebay User ID: reveleus1

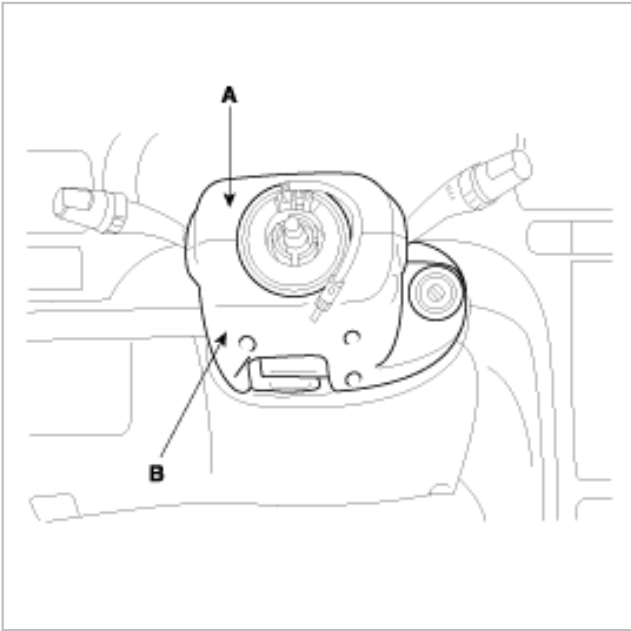

6. Remove the connectors of the multifunction switch(A).

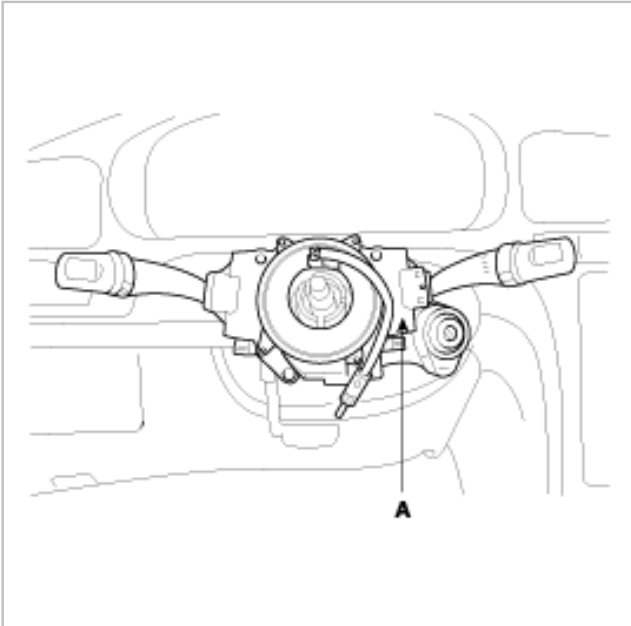

7. After removing three bolts(A) in the illustration, remove the multifunction switch assembly(B).

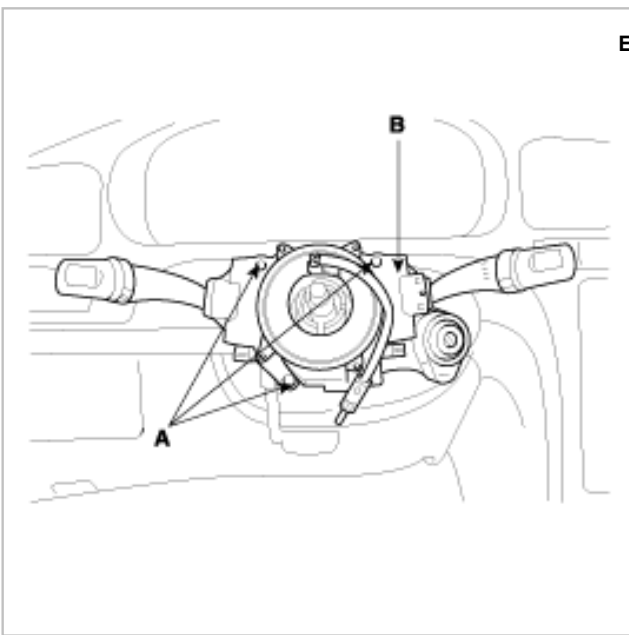

8. Remove the lower crash pad(A) after loosening the four bolts(B) in the illustration.

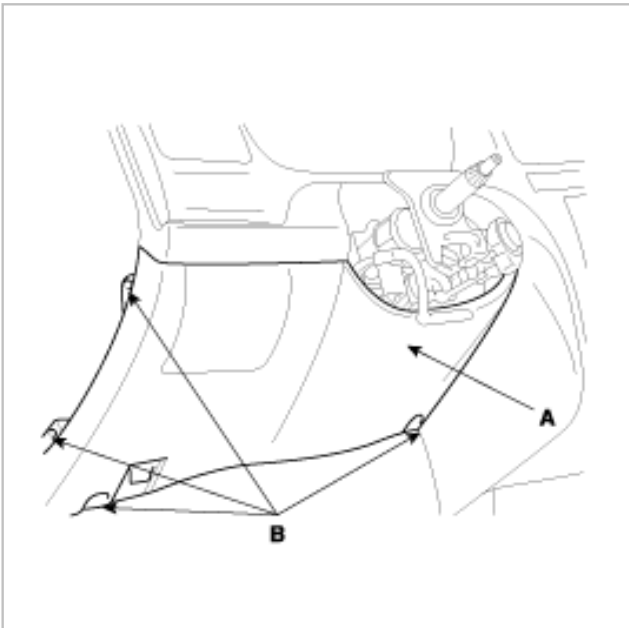

9. Remove the five bolts connecting the steering column shaft(A) and the universal joint(B) as shown in the illustration.

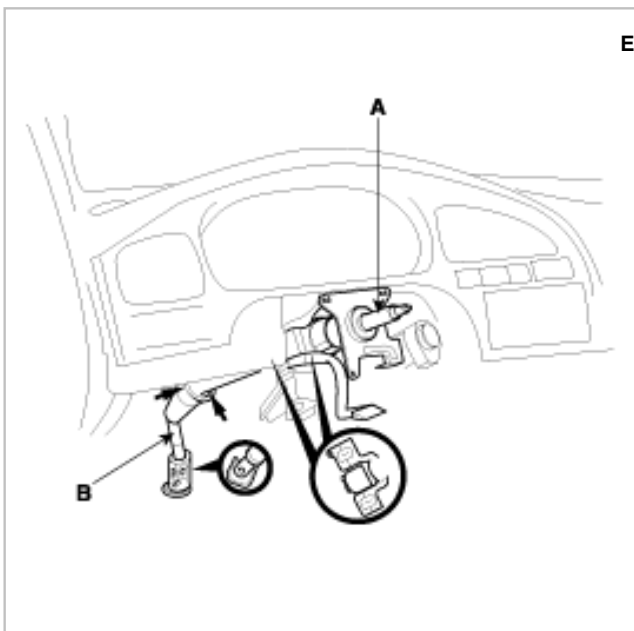

10. After removing the mounting bolts and nuts, remove the steering column and shaft assembly(A).

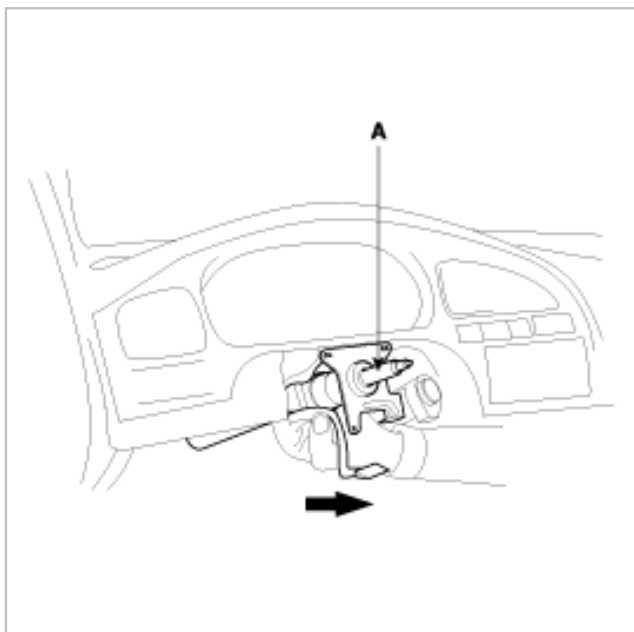

INSTALLATION

Assembly is the reverse of removal.

DISASSEMBLY AND REASSEMBLY

KEY LOCK ASSEMBLY

1. If it is necessary to remove the key lock assembly(A), use a punch to make a groove on the head of the special bolt(B), and then use a screwdriver to remove the key lock assembly mounting bracket(C).

Ebay User ID: reveleus1

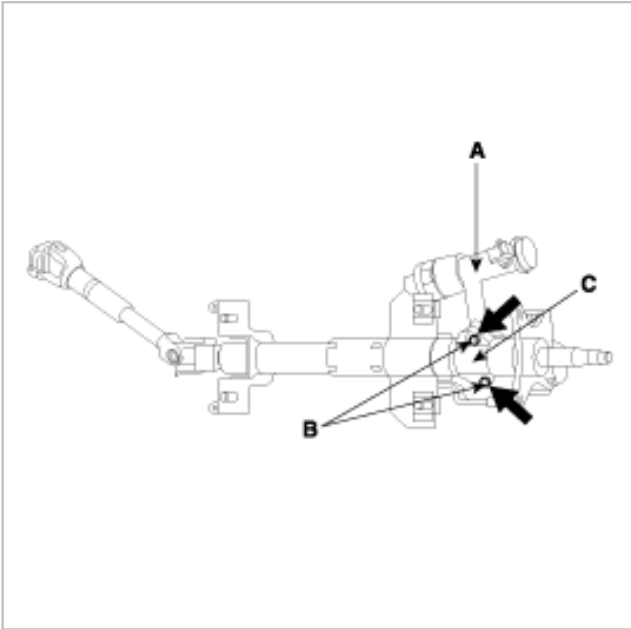

2. Disassemble the key lock assembly(A) from the steering column and shaft assembly(B).

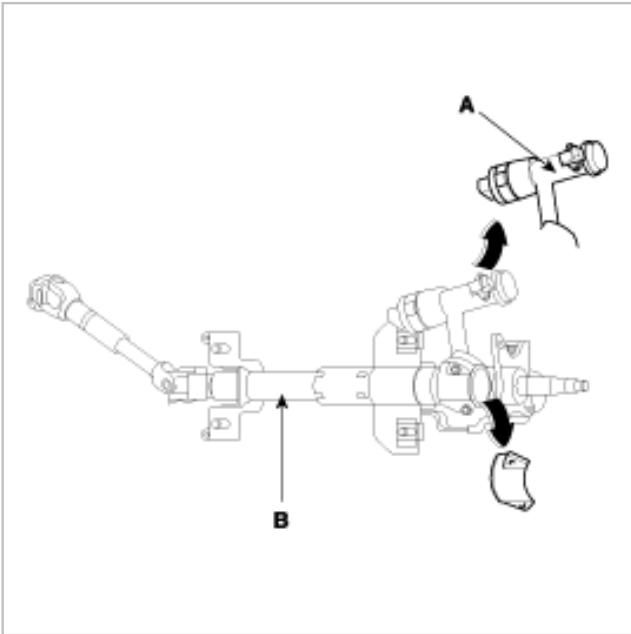

3. Reassembly is the reverse of disassembly.

UNIVERSAL JOINT ASSEMBLY

1. Remove the bolt(A) connecting the universal joint assembly(B) and the steering column and shaft assembly(C).

Ebay User ID: reveleus1

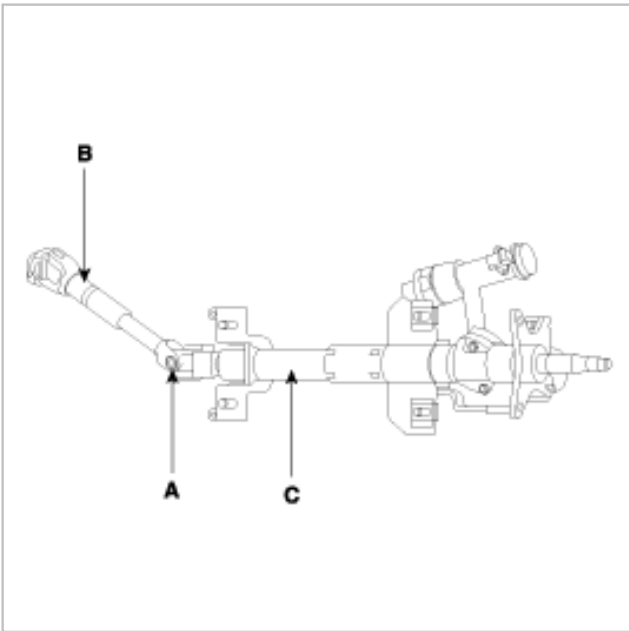

2. Remove the universal joint assembly(A) from the steering column and shaft assembly(B).

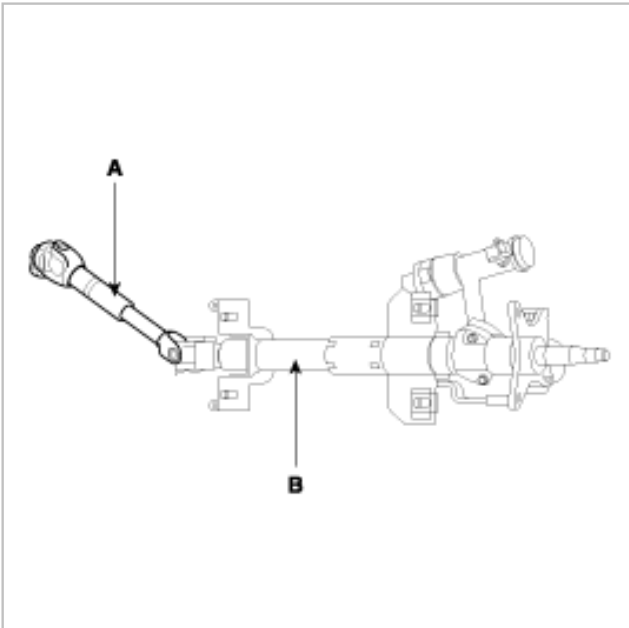

3. Reassembly is the reverse of disassembly.

INSPECTION

1. Check the steering column shaft for damage and deformation.
2. Check connections for play, damage and smooth operation.
3. Check the ball joint bearing for wear and damage.



TROUBLESHOOTING

Symptom	Probable cause	Remedy (see page)
Excessive play in steering	Loose yoke plug Loose steering gear mounting bolts Loose or worn tie rod end	Retighten (See page ST-30) Retighten Retighten or replace as necessary (See page ST-8)
Steering wheel operation is not smooth (Insufficient power assist)	V-belt slippage Damaged V-belt Low fluid level Air in the fluid Twisted or damaged hoses Insufficient oil pump pressure Sticky flow control valve Excessive internal oil pump leakage Excessive oil leaks from rack and pinion in gear box Distorted or damaged gear box or valve body seals	Readjust (See page ST-9) Replace Replenish (See page ST-10) Bleed air (See page ST-10) Correct the routing or replace Repair or replace the oil pump (See page ST-11) Replace Replace the damaged parts Replace the damaged parts Replace
Steering wheel does not return properly	Excessive turning resistance of tierod end Yoke plug excessively tight Tie rod and/or ball joint cannot turn smoothly Loose mounting of gear box mounting bracket Worn steering shaft joint and/or body grommet Distorted rack Damaged pinion bearing Twisted or damaged hoses Damaged oil pressure control valve Damaged oil pump input shaft bearing	Replace (See page ST-21) Adjust (See page ST-30) Replace (See page ST-8) Retighten Correct or replace Replace (See page ST-26) Replace Reposition or replace Replace Replace

Noise	<p>Hissing Noise in Steering Gear</p> <p>There is some noise with all power steering systems. One of the most common is a hissing sound when the steering wheel is turned and the car is not moving. This noise will be most evident when turning the wheel while the brakes are being applied. There is no relationship between this noise and steering performance. Do not replace the valve unless the "hissing" noise becomes extreme. A replaced valve will also make a slight noise, and is not always a solution for the condition</p>	
Rattling or chucking noise in the rack and pinion	<p>Interference with hoses from vehicle body</p> <p>Loose gear box bracket</p> <p>Loose tie rod end and/or ball joint</p> <p>Worn tie rod and/or ball joint</p>	<p>Reposition</p> <p>Retighten</p> <p>Retighten</p> <p>Replace (See page ST-8)</p>
Noise in the oil pump	<p>Low fluid level</p> <p>Air in the fluid</p> <p>Loose pump mounting bolts</p>	<p>Replenish (See page ST-10)</p> <p>Bleed air (See page ST-10)</p> <p>Retighten</p>

NOTE

A slight "grinding noise" may be heard immediately after the engine is started in extremely cold weather conditions (below -20°C). This is due to power steering fluid characteristics in extreme cold conditions and is not an indication of a malfunction.