



HYUNDAI

Elantra



*Workshop Manual*  
*2001 - 2006*



## DESCRIPTION

The front suspension system consists of the following components.

- Front strut assemblies
- Front lower arm assemblies
- Front stabilizer bar and links

The front strut and spring assemblies can be disassembled to install any of the new individual components. New LH or RH front strut and spring assemblies can be installed independently.

The front suspension system can also be disassembled in order to install new.

- Front lower arms
- Front lower arm mounting bolt bushings

New front stabilizer bar components can be installed individually.

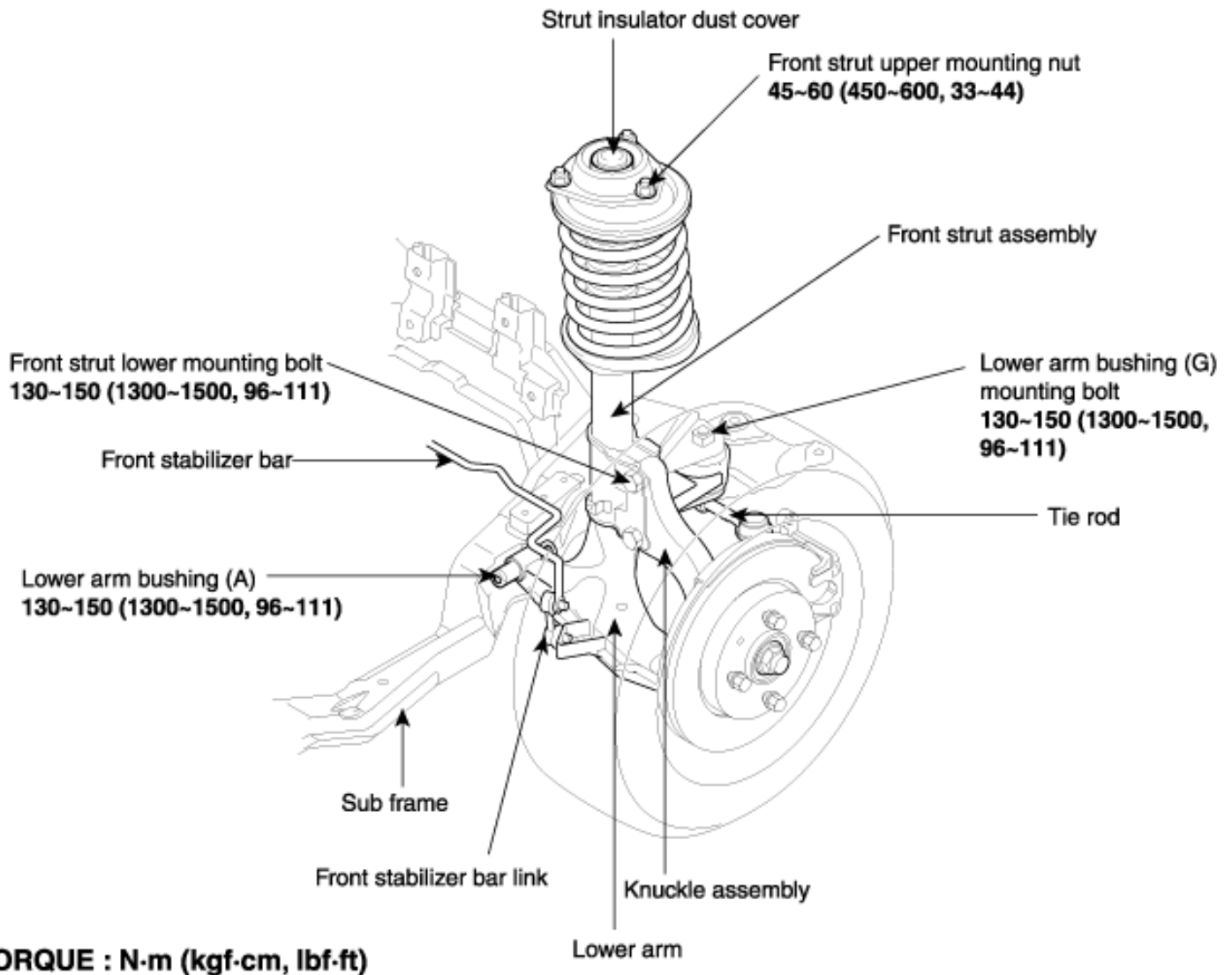

# COMPONENTS

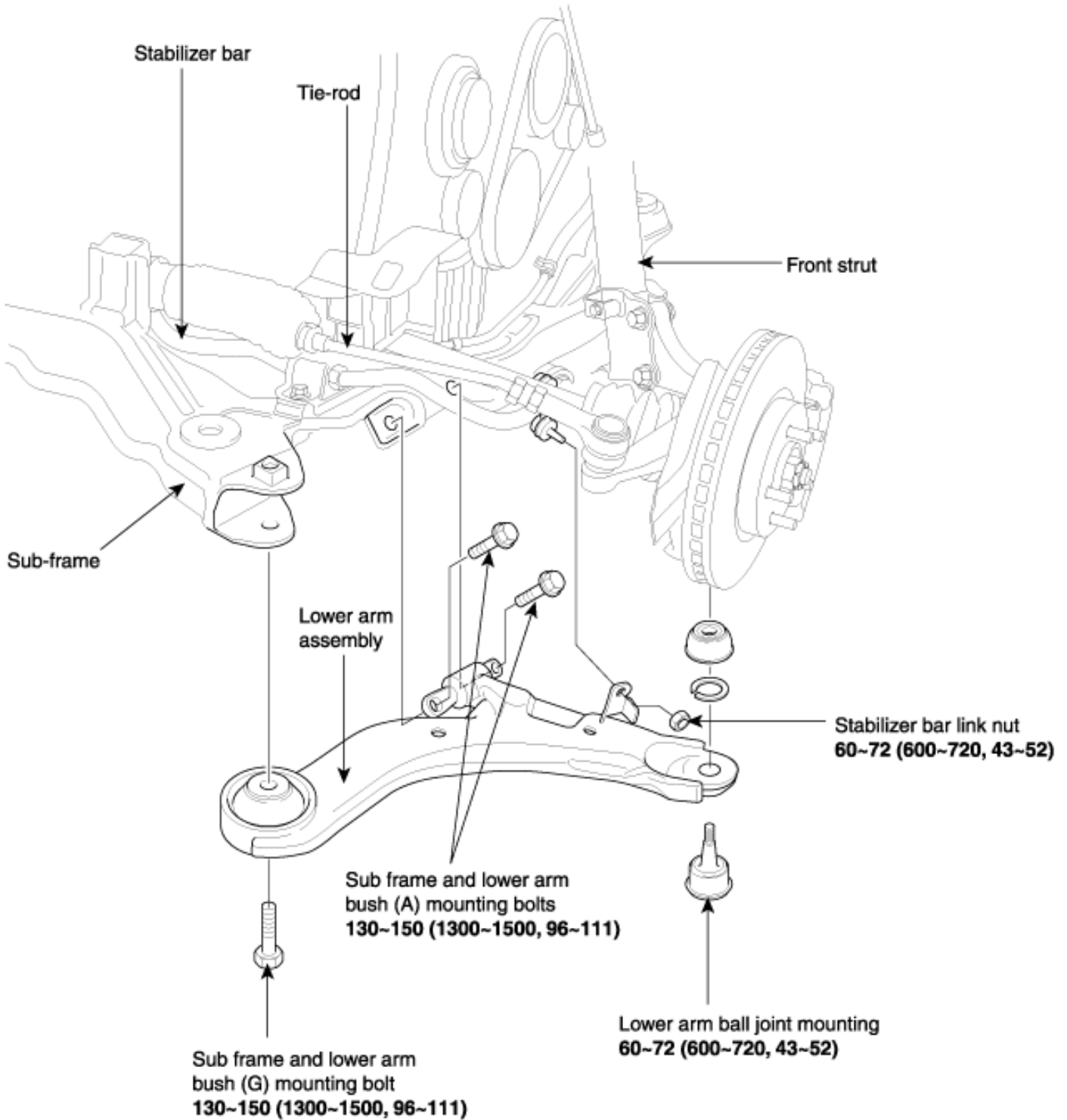

**TORQUE : N·m (kgf·cm, lbf·ft)**

## INSPECTION

1. Check the bushing for wear and deterioration.
2. Check the lower arm for bending or breakage.
3. Check the ball joint dust cover for cracks and damage.
4. Check all bolts for damage and deformation.
5. Measure the ball joint rotating torque.

---

### Standard value

2~3.5 Nm (20~35 kgf.cm, 1.4~2.5 lbf.ft)

---

- A. If the rotating torque is exceeds the limit of the standard value, replace the ball joint assembly.
- B. Even if the rotating torque is below the lower limit of the standard value, the ball joint may be reused unless it has drag and excessive play.

## NOTE

Measure torque using the special tool (09532-11600) and torque wrench(C) at the range of 0.5~2 rpm after moving the ball joint stud(A) 3° several times at room temperature.

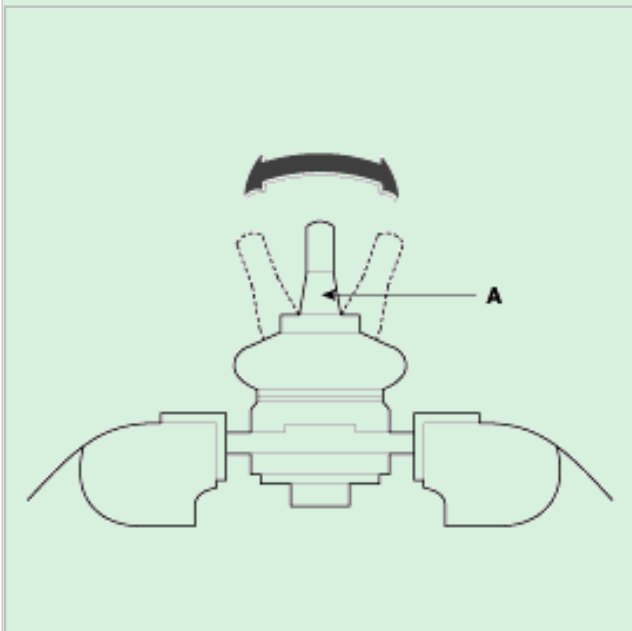

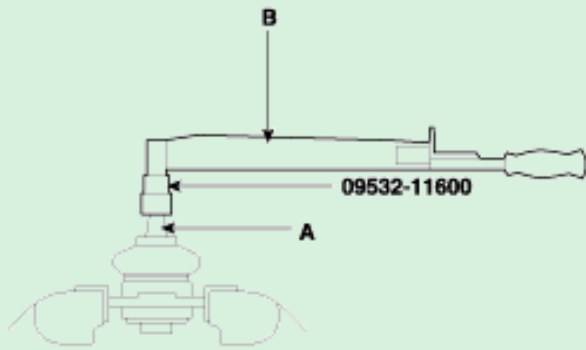

## REMOVAL

1. Remove the front wheel and tire.
2. Remove the split pin, the castle nut and the washer.
3. Loosen the lower arm ball joint nut(A), but do not remove it.

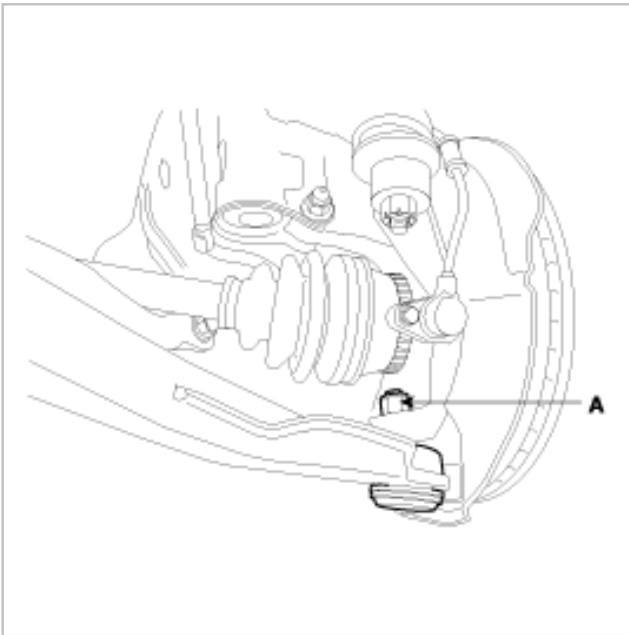

4. Remove the front strut lower mounting bolts(A) from the strut assembly(B).

Ebay User ID: reveleus1

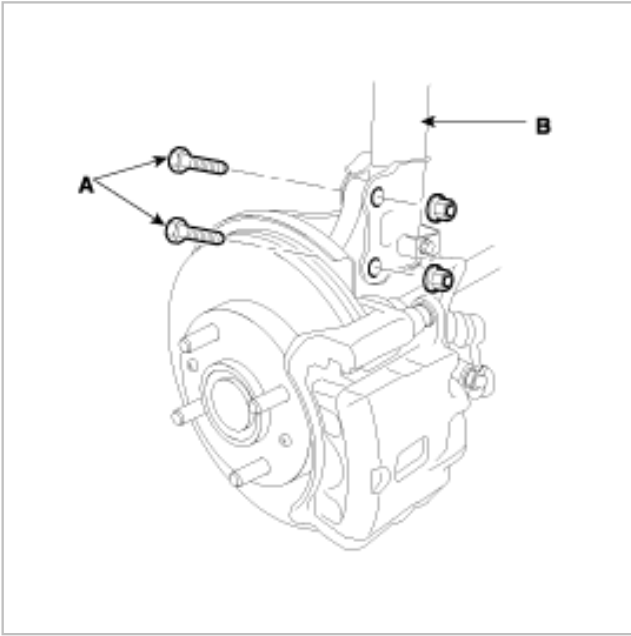

5. Push the axle hub(A) outward to install the Special tool (09568-34000) easily.

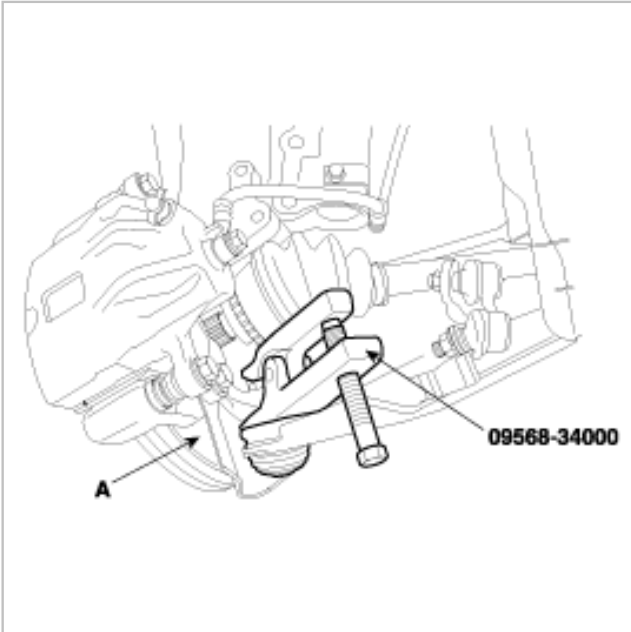

6. Using the Special Tool (09568 - 34000), disconnect the lower arm ball joint(C) from the lower arm(B).

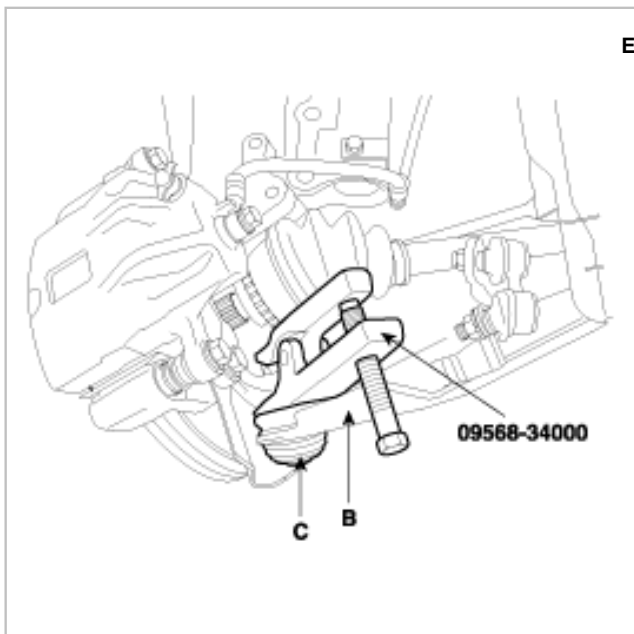

7. Remove the stabilizer link nut(A).

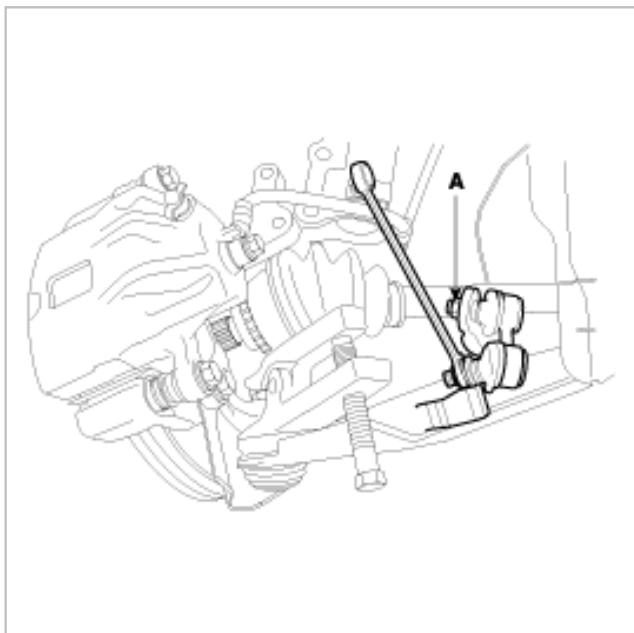

8. Temporarily install the strut lower mounting bolt.

9. To the lower arm mounting bolt, remove the passenger seat side cover(A).

**NOTE**

It can be easily removed by loosening the mounting bolts(B).

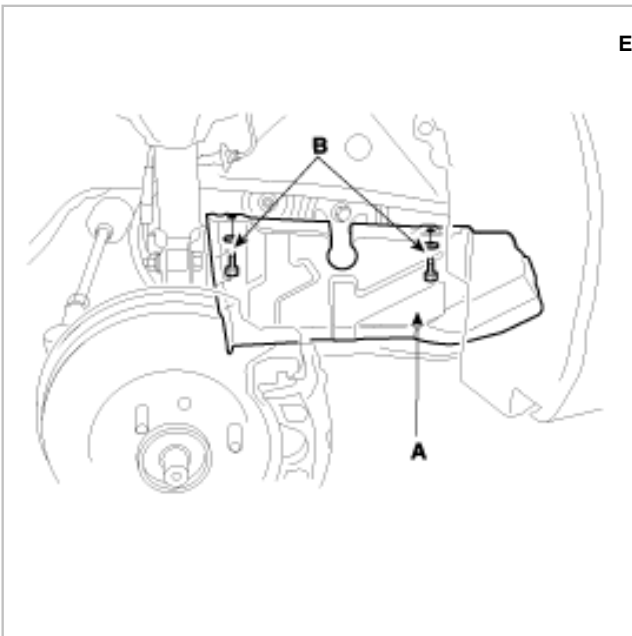

10. Remove the lower arm mounting bolts(A,B,C).

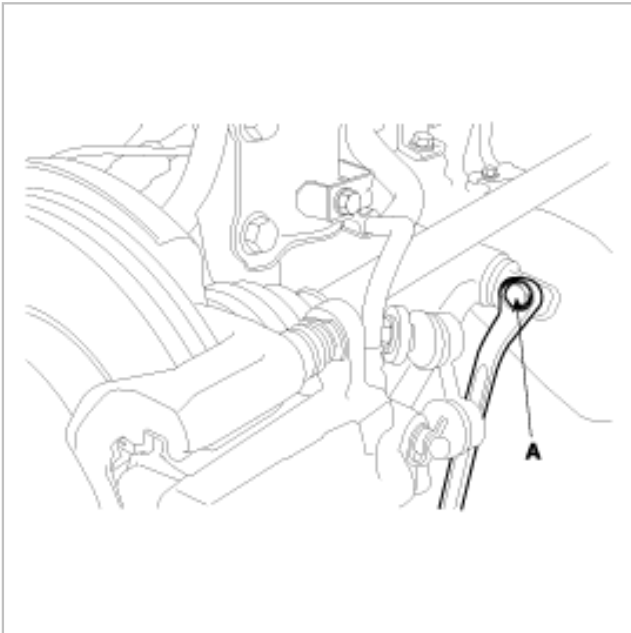



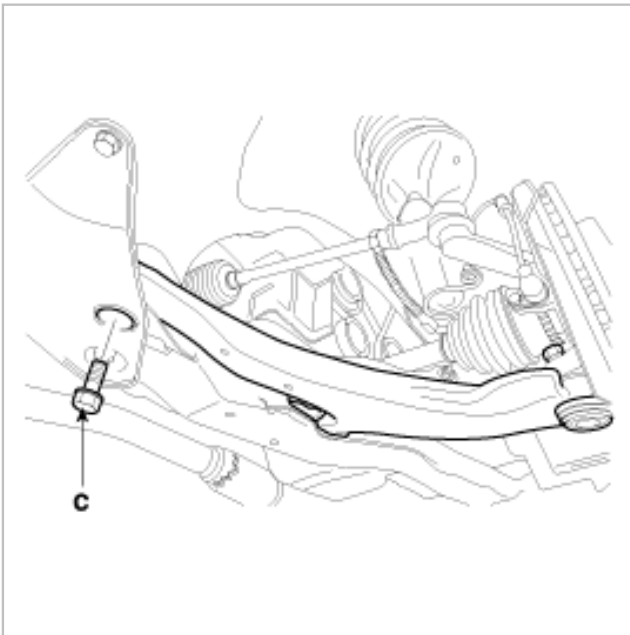
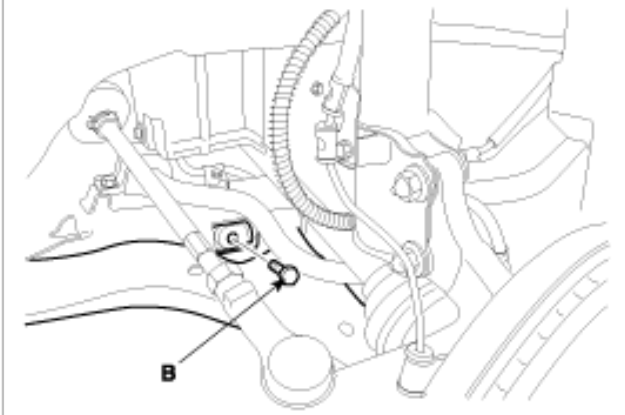

11. Remove the lower arm assembly after completely unfastening the nut of lower arm ball joint which was loosened temporarily in step 3.

## INSTALLATION

Installation is the reverse of the removal procedure.

## REPLACEMENT

### BALL JOINT AND DUST COVER

1. Using a flat-tipped (-) screwdriver(A), remove the dust cover(C) from the lower arm ball joint(B).  
Ebay User ID: reveleus1

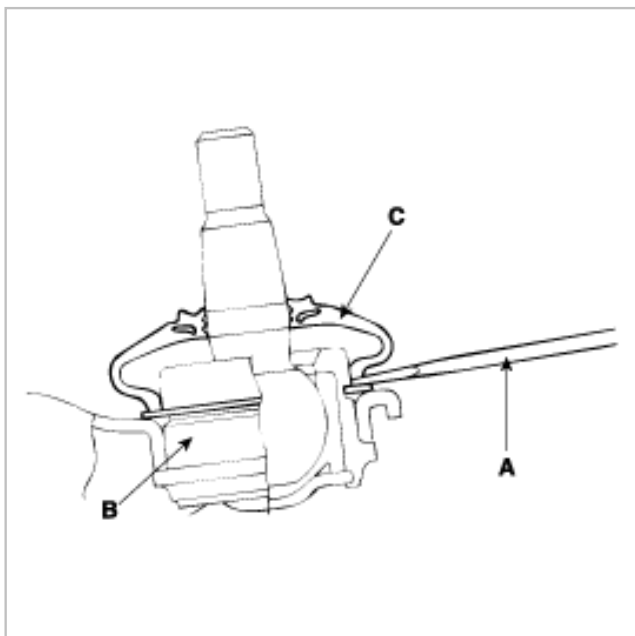

2. Remove the snap ring(A).

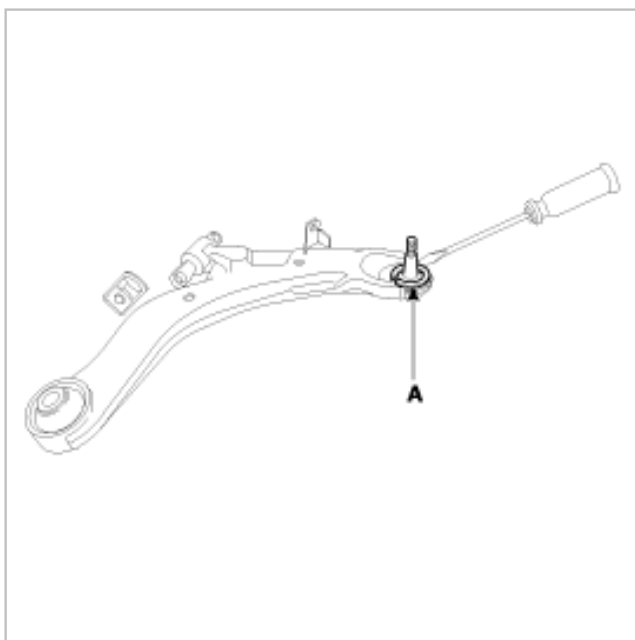

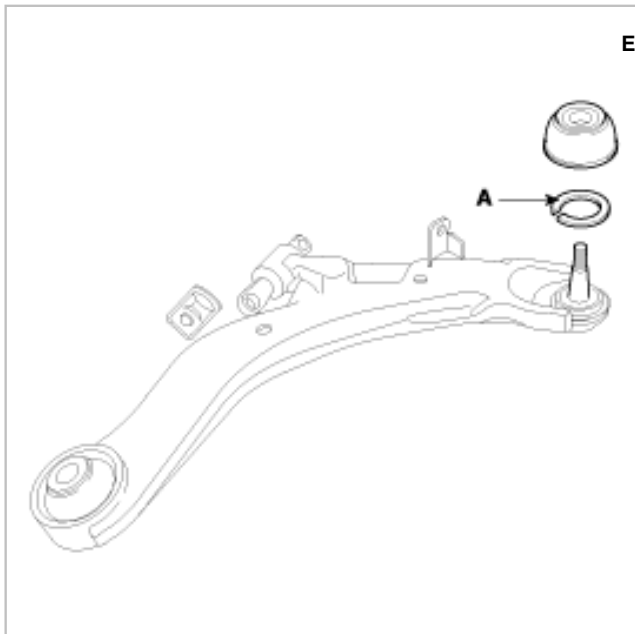

3. Using a plastic hammer or the Special tool(09545-3A000), separate the ball joint(B) from the lower arm(A).

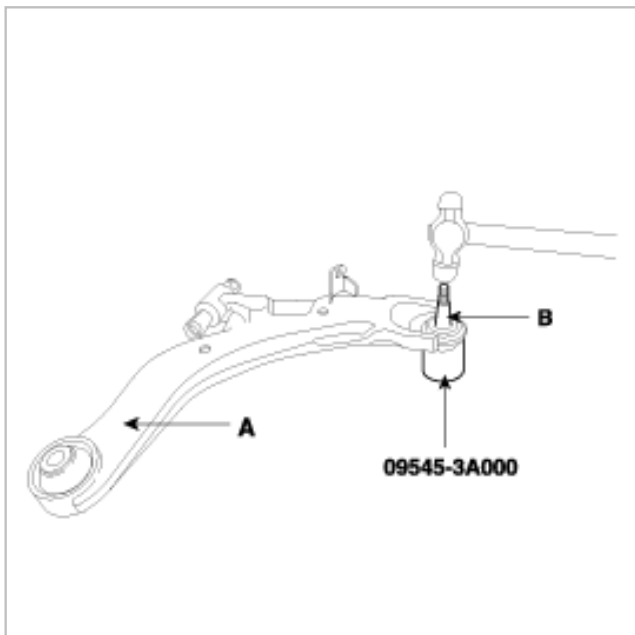

4. Using the Special tool (09545 - 11000A/B), press-fit the ball joint into the lower arm assembly(A).

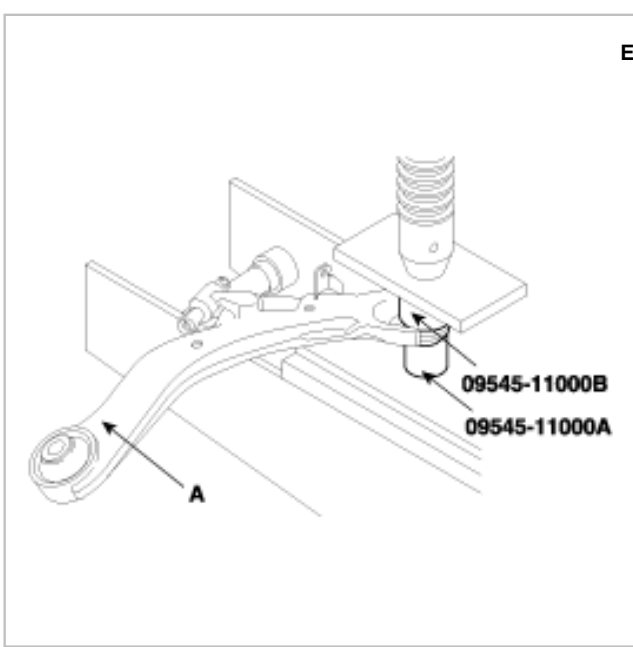

5. Install the snap ring.
6. Using the Special tool (09545 - 21100), install the dust cover.

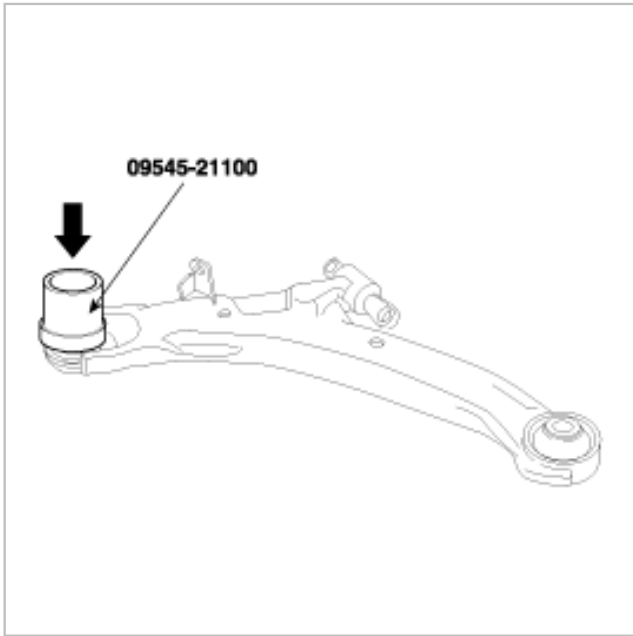

### **LOWER ARM BUSHING (G)**

1. Install the Special tools (09545 - 02000, 09216 - 21200, 09216 - 21200) on the lower arm.
2. Press out the bushing.

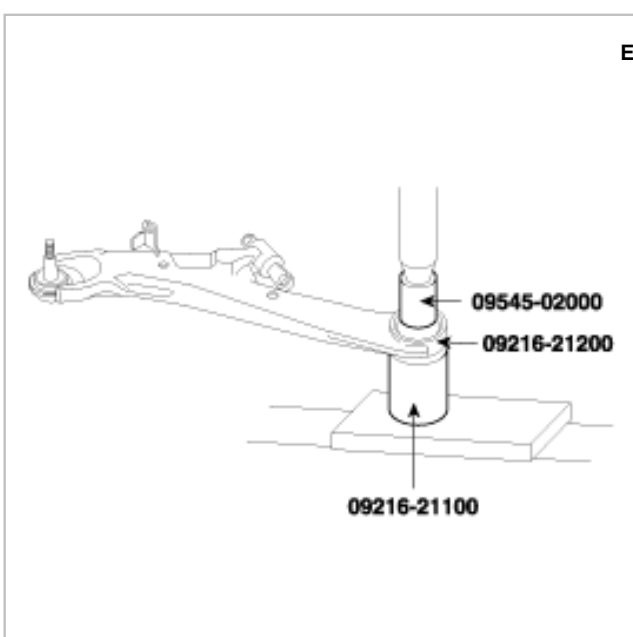

3. Apply soap solution to the following parts.

A. Outer surface of the bushing.

B. Inner surface of the lower arm bushing mounting part.

4. Install the new bushing on the lower arm using the Special Tools (09216 - 21100, 09624 - 34000).

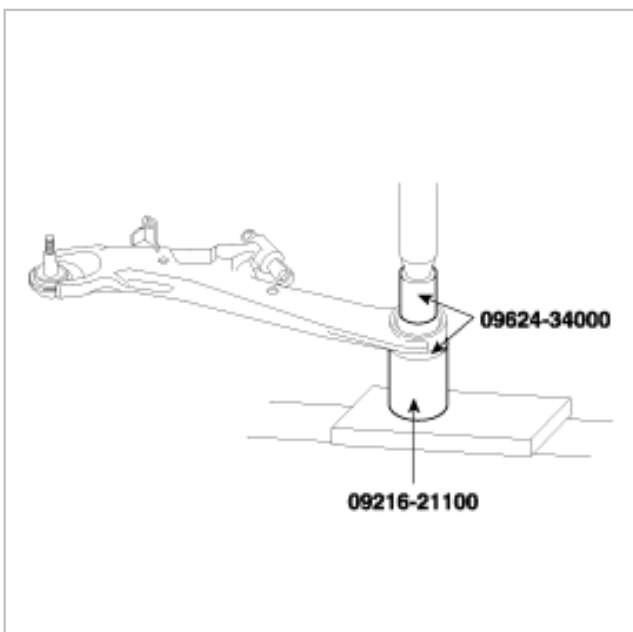

#### NOTE

Press-in the lower arm bushing (G) in the same direction as shown in illustration.

Pull out force for the bushing :

80 N [800 kg(f), 11.9 lb(f)] or more

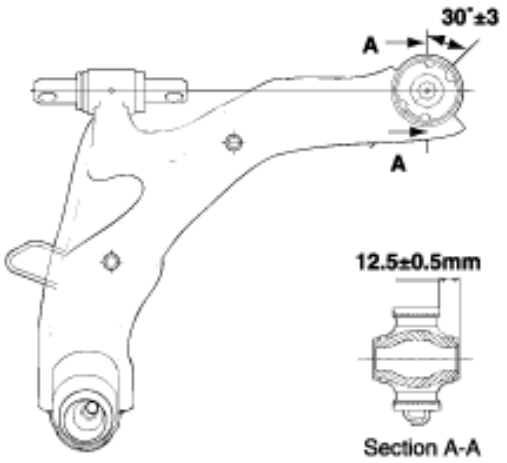

# COMPONENTS

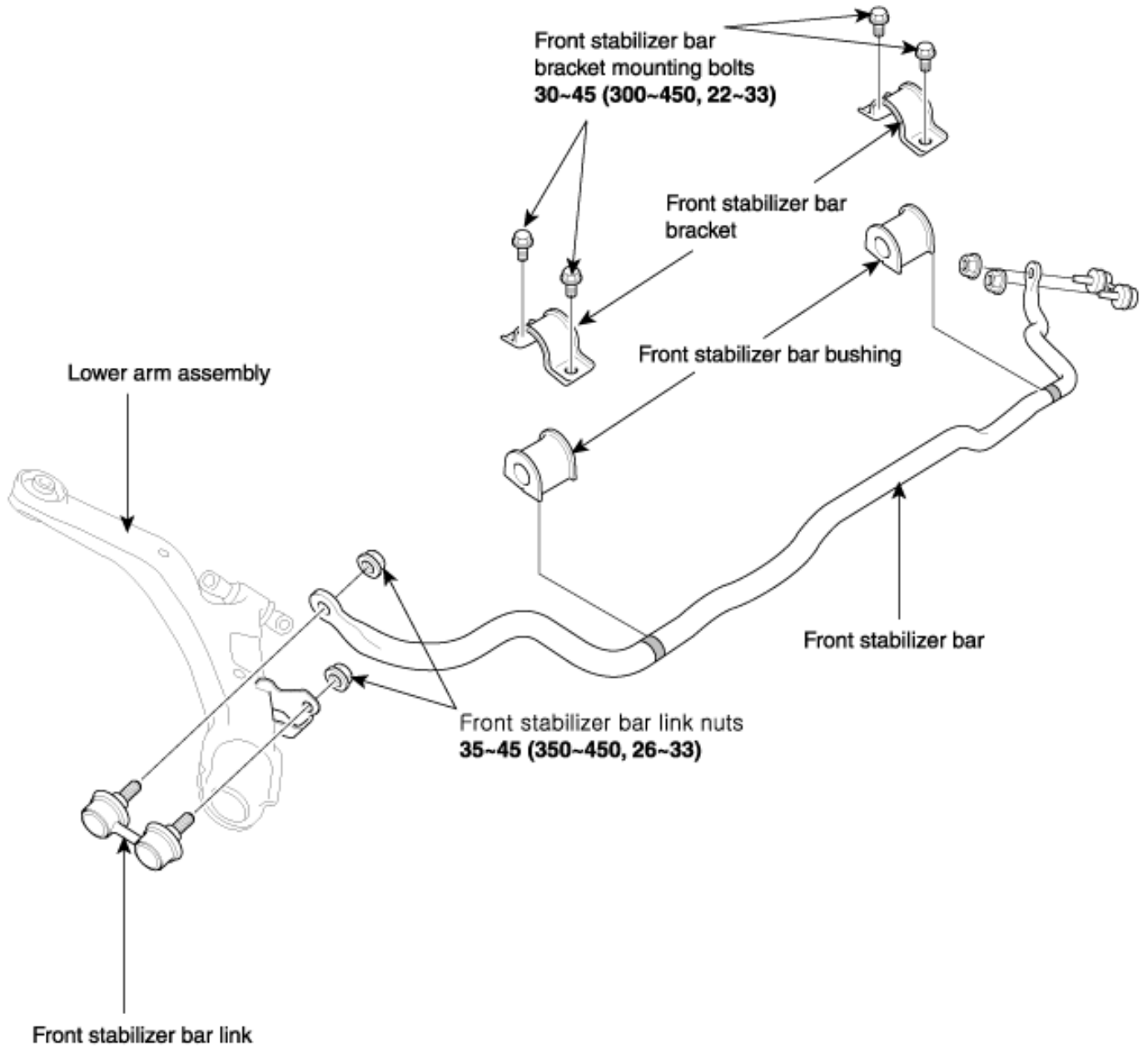

**TORQUE : N·m (kgf·cm, lbf·ft)**

## REMOVAL

1. Remove the front wheel and tire.
2. Remove the stabilizer bar link assembly (A).

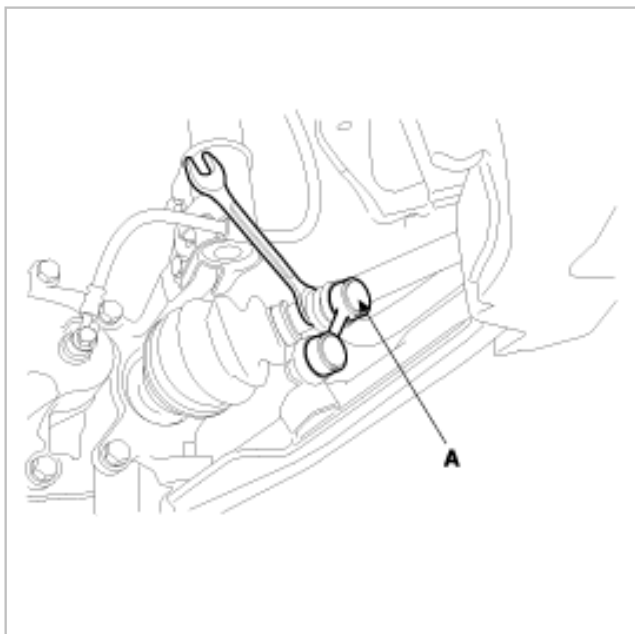

A. Remove the bolts(B) and stabilizer bar link(A).

### NOTE

If the stabilizer bar link ball joint(C) and nuts(B) turn altogether, use the pentagonal wrench to hold the stud.

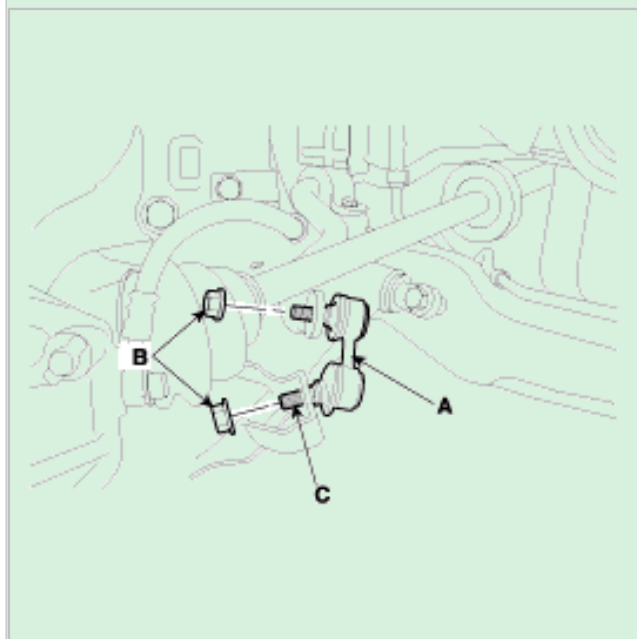



B. Remove the stabilizer bar link on the opposite side in the same way.

Ebay User ID: reveleus1

### CAUTION

Be careful not to damage the ball joint boot.

3. Remove the stabilizer bracket(A) and bushing(B)

A. After loosen the bolts(C-in case of LH, separate pad by loosening the fixing bolts of the stabilizer bar bracket), then remove the bracket(A) and bushing(B)

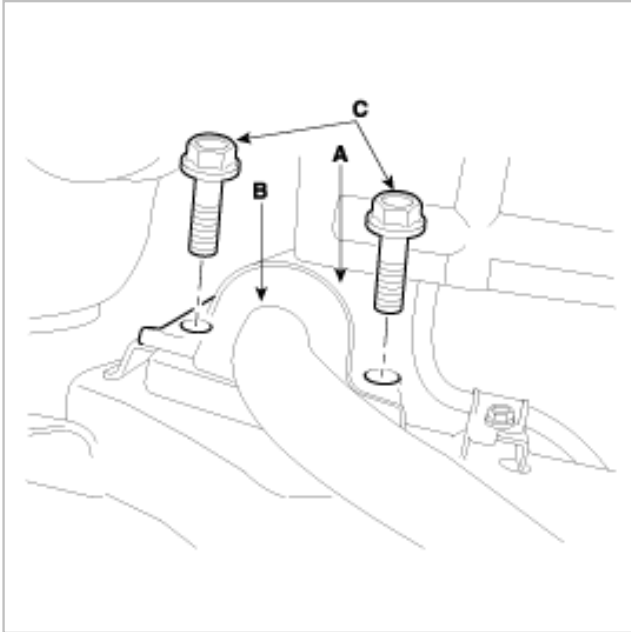

B. Remove the stabilizer bar link on the opposite side in the same way.

C. Remove the stabilizer out of the vehicle's right side.

## INSTALLATION

1. Install the bushing on the stabilizer bar.

### NOTE

The distance between the bushing, and the part to which white paint is applied, must continue 10mm outside the vehicle.

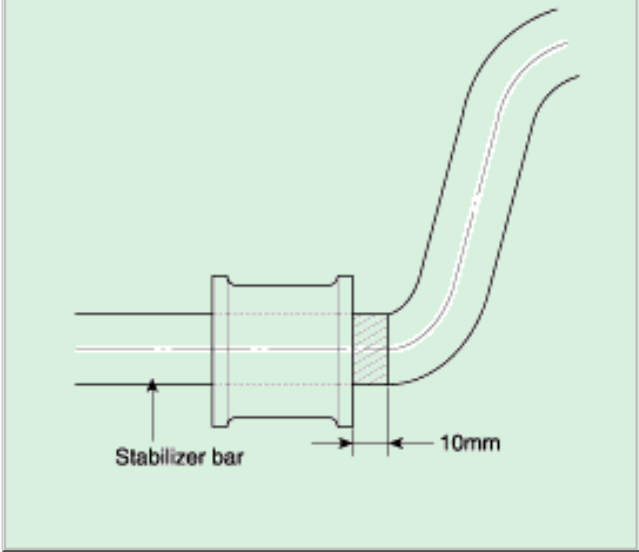

2. Install the bracket on the bushing
3. Align and install the bushing with the white paint on the stabilizer bar. After tightening the bolts of the bushing bracket temporarily, install the bushing bracket on the opposite side.

## INSPECTION

1. Check the stabilizer bar for deterioration and damage.
2. Check all bolts for damage and deformation.
3. Check the stabilizer link dust cover for cracks or damage.
4. Check the stabilizer link ball joint(A) for rotating torque.

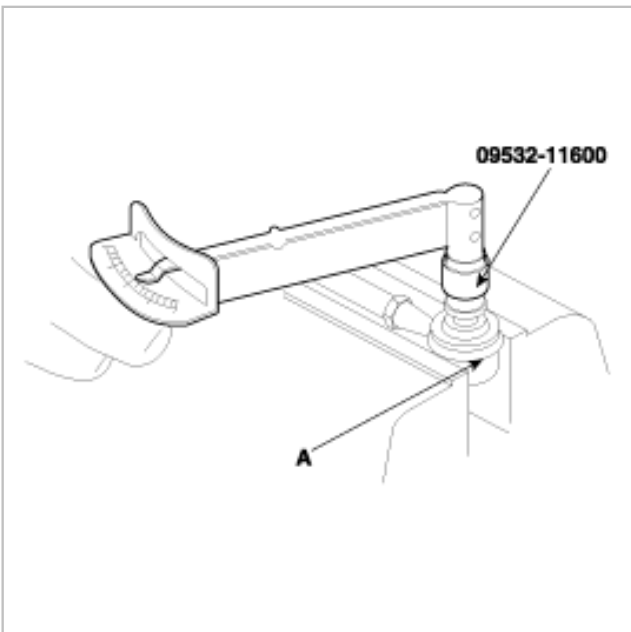

- A. If there is a crack in the dust cover, replace it and add grease.
- B. Shake the stabilizer link ball joint stud several times.

C. Mount the self-locking nut on the ball joint, and then measure the ball joint rotating torque.

Ebay User ID: reveleus1

---

**Standard value**

1.7~3.2 Nm (17~32 kgf·cm, 15~27 lbf·in)

---

D. If the rotating torque is higher than the upper limit of the standard value, replace the stabilizer link.

E. If the rotating torque is below the lower limit of the standard value, the ball joint may be reused unless it has drag and excessive play.

# COMPONENTS

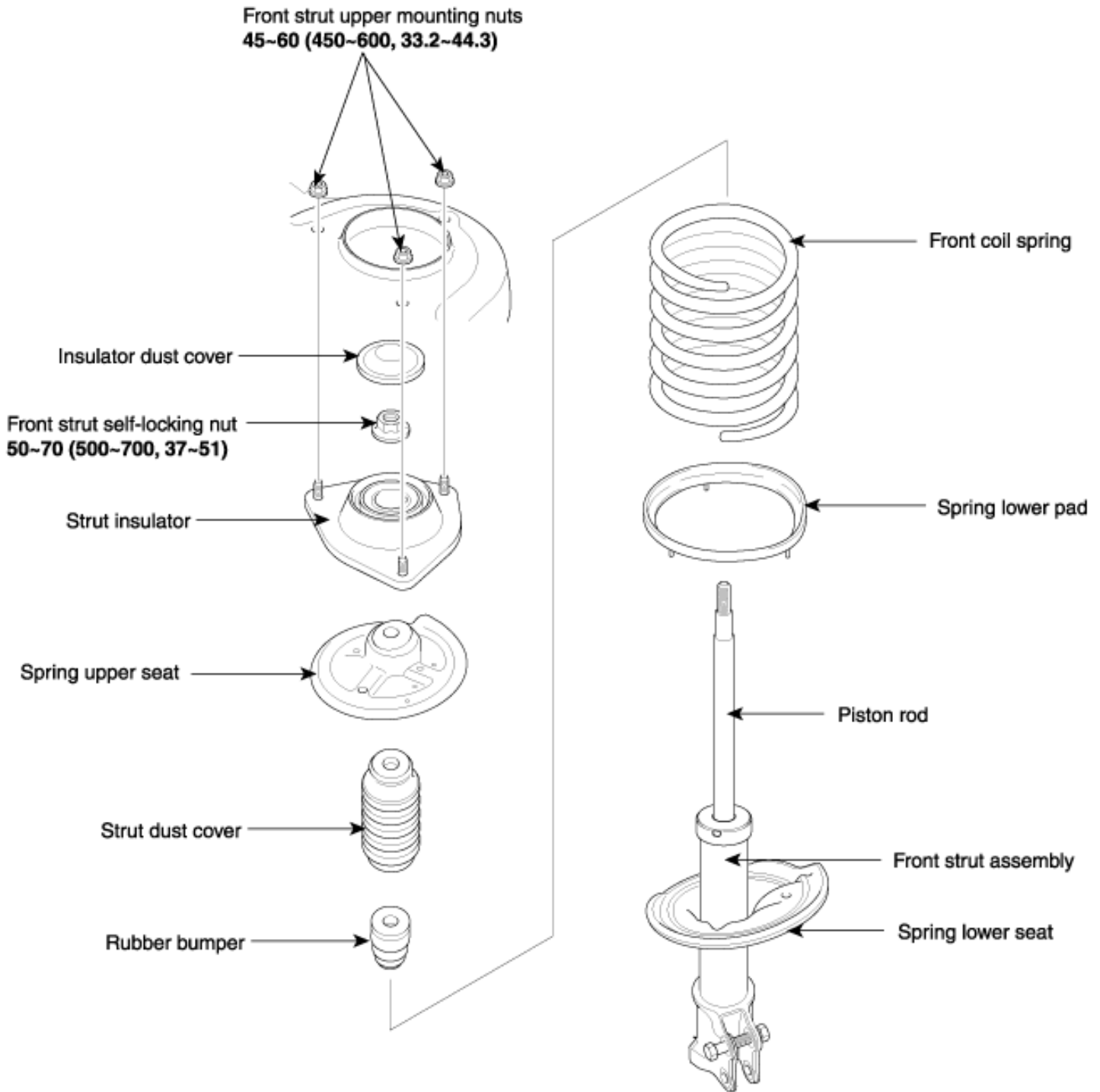

**TORQUE : N·m (kgf·cm, lbf·ft)**

## INSPECTION

1. Check the strut insulator bearing for wear or damage.
2. Check rubber parts for damage or deterioration.
3. Compress and extend the piston rod(A) and check that there is no abnormal resistance or unusual sound during operation.

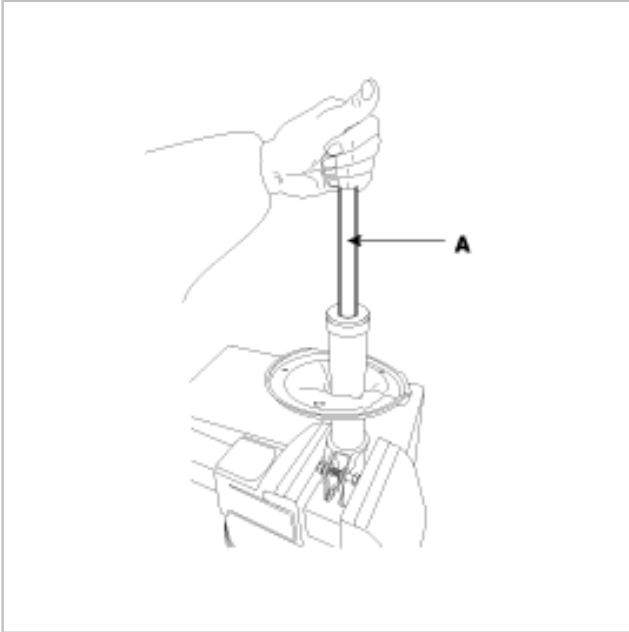

## DISASSEMBLY

1. Remove the dust cover(A) with a flat-tipped (-) screwdriver(B).

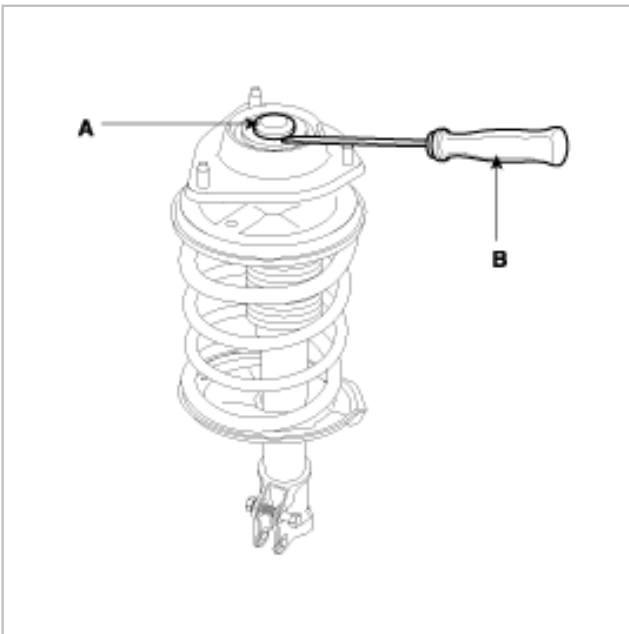

2. Open the dust cover and wipe off grease in the insulator(A).  
Ebay User ID: reveleus1

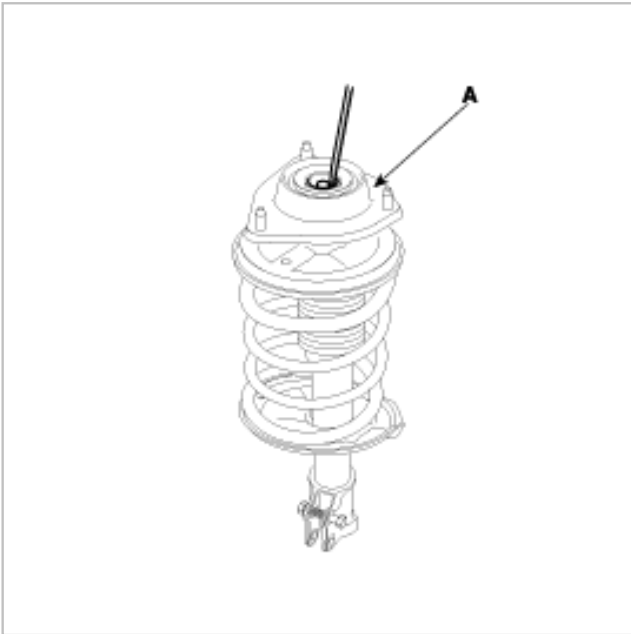

3. Using the Special Tool (J38402, A-50), compress the coil spring(A) until there is only a little tension of the spring on the strut.

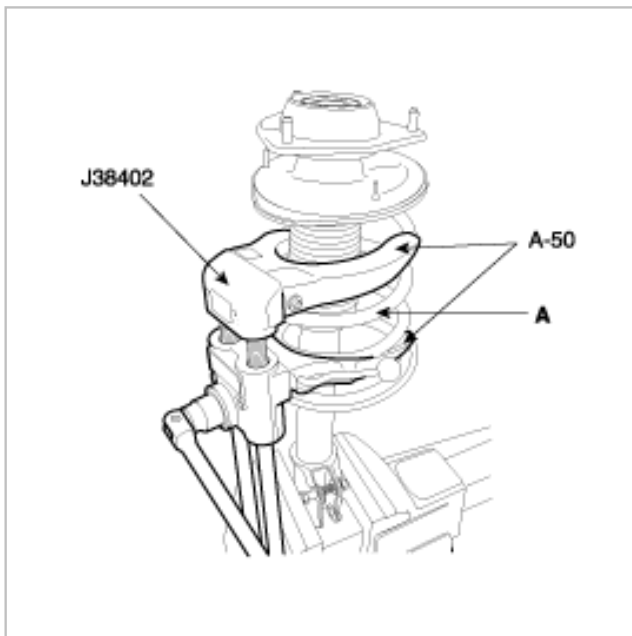

#### NOTE

- When compress the coil spring, do not use an impact gun.

4. Under the condition of fixed strut(A) on the vise(B), remove the front strut self-locking nut(C).  
Ebay User ID: reveleus1

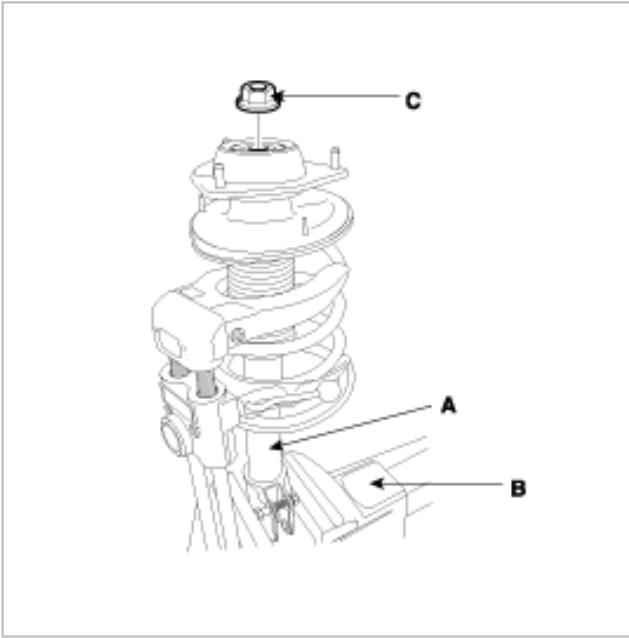

5. Remove the insulator, spring seat, coil spring and dust cover from the strut assembly

## REASSEMBLY

1. Install lower spring pad so that the protrusions fit in the holes of the spring lower seat.
2. Install the strut dust cover(A) and rubber bump(B) to piston rod.

### CAUTION

Compress the piston rod until engaging two grooves(A,B).

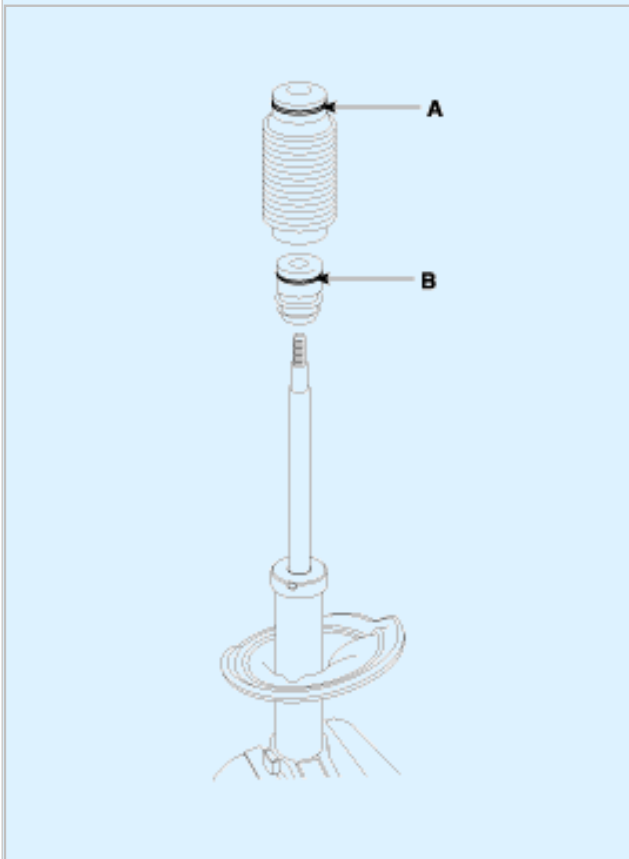

3. Compress coil spring using Special tool (J38402, A-50).  
Install compressed coil spring into shock absorber.

Ebay User ID: reveleus1

## NOTE

1. Indicated two identification color marks on the coil spring; one follows model option (see page SS-2) the other follows load classification according to the below.

Pay attention to distinguish between the two marks and then install them.

Left wheel side(LH)		Right wheel side(RH)
WHITE	← →	WHITE
YELLOW	← →	YELLOW
RED	← →	RED

2. Install the coil spring with the identification mark directed toward the knuckle.

4. After fully extending the piston rod, install the spring upper seat and insulator assembly.
5. After seating the upper and lower ends of the coil spring(A) in the upper and lower spring seat grooves(B) correctly, tighten new self-locking nut temporarily.



6. Remove the Special Tool(J38402, A-50).
7. Tighten the self-locking nut to the specified torque.

### Tightening torque

50~70 Nm (500~700 kgf.cm, 37~51 lbf.ft)

8. Apply grease to the strut upper bearing and install the insulator cap.

## CAUTION

When applying the grease, be careful so that it isn't smeared on the insulator rubber.

## REMOVAL

1. Remove the front wheel and tire.



2. Detach the brake hose bracket(B) from the front strut assembly(A).  
Ebay User ID: reveleus1

**NOTE**

Do not apply excessive force to the components.

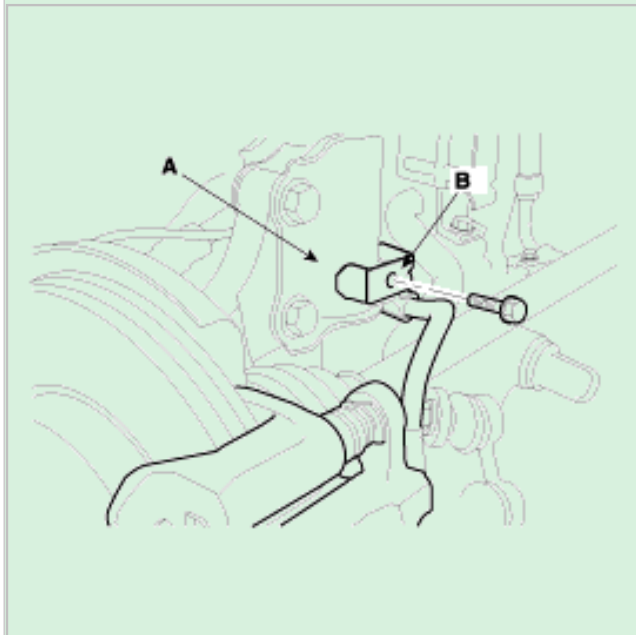

3. In case of the vehicles equipped with Anti-lock Brake system, remove the wheel speed sensor(A) from the knuckle(B).

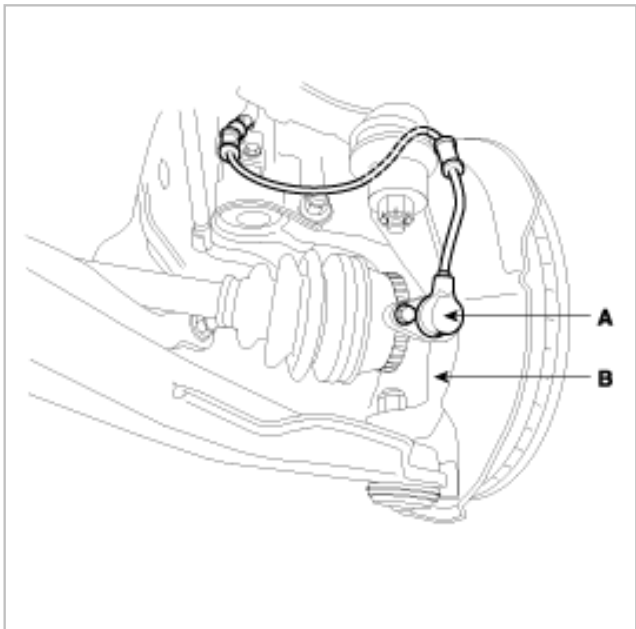

4. Remove the strut upper mounting nuts (A).

Ebay User ID: reveleus1

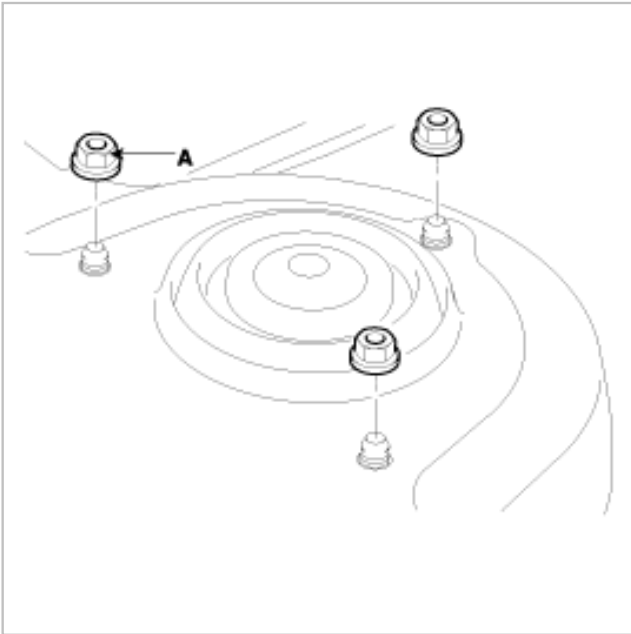

5. Remove the strut lower mounting bolts(A) and then remove the strut assembly(B).

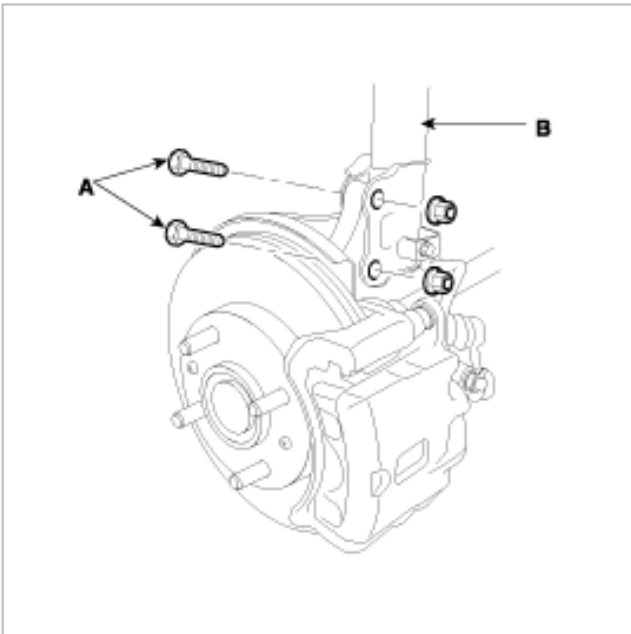

## INSTALLATION

1. Installation is the reverse of the removal procedure.

### NOTE

After installation, check the front wheel alignment.

## DISPOSAL

1. Fully extend the piston rod.

2. Drill a hole on the A section to remove gas from the cylinder.  
Ebay User ID: reveleus1

**CAUTION**

The gas coming out is harmless, but be careful of chips that may fly when drilling.

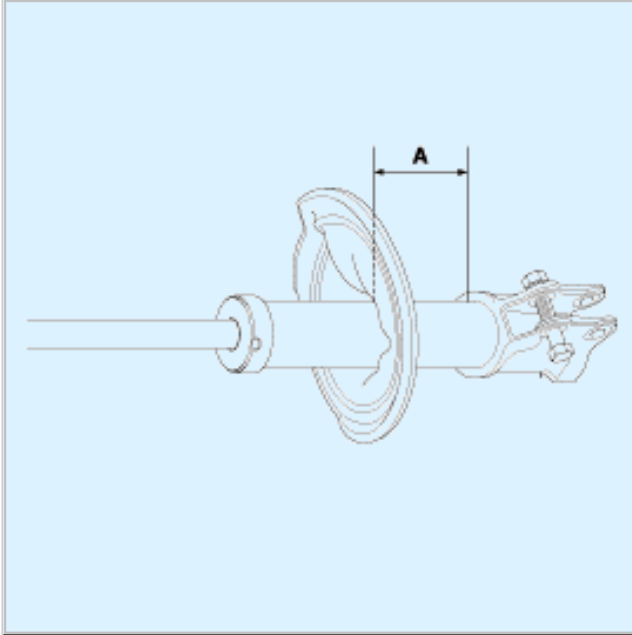

# COMPONENTS

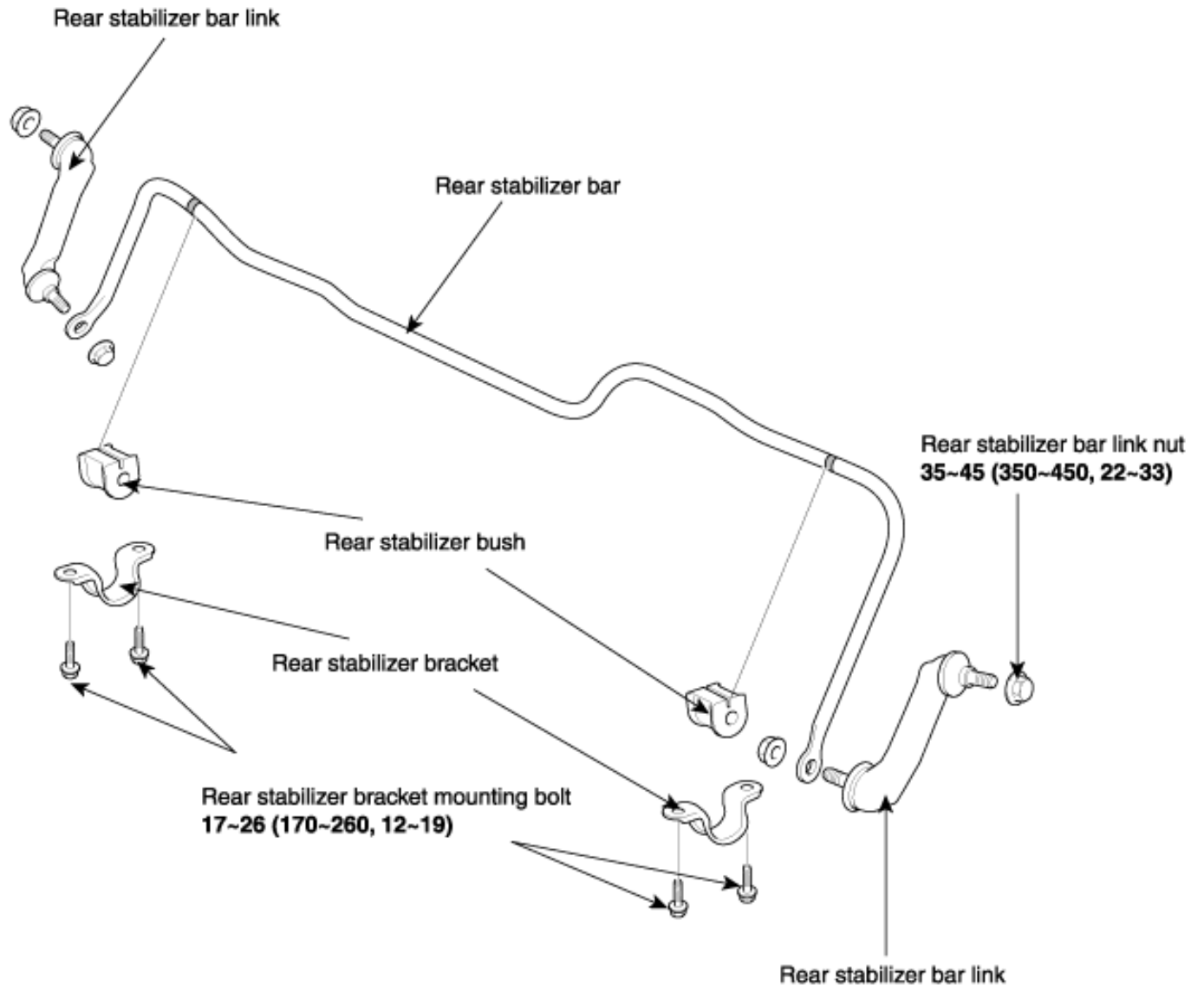

**TORQUE : N·m (kgf·cm, lbf·ft)**

## REMOVAL

1. Remove the stabilizer bar link(A) from the rear strut assembly(B).

### NOTE

If the ball joint(C) and nuts(D) turn altogether, use the pentagonal wrench to hold the stud(E).

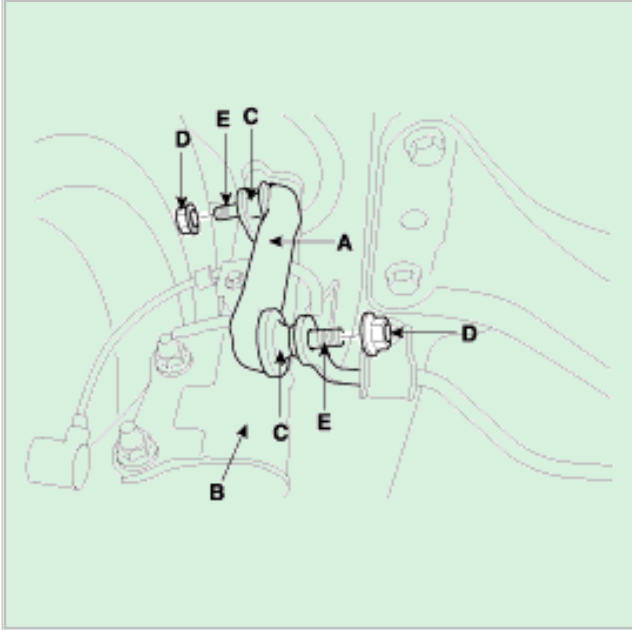

2. Remove the rear stabilizer bar mounting brackets.
3. Remove the stabilizer bar link on the opposite side in the same way.
4. Remove the mounting nuts(B,C) of the exhaust pipe assembly(A).

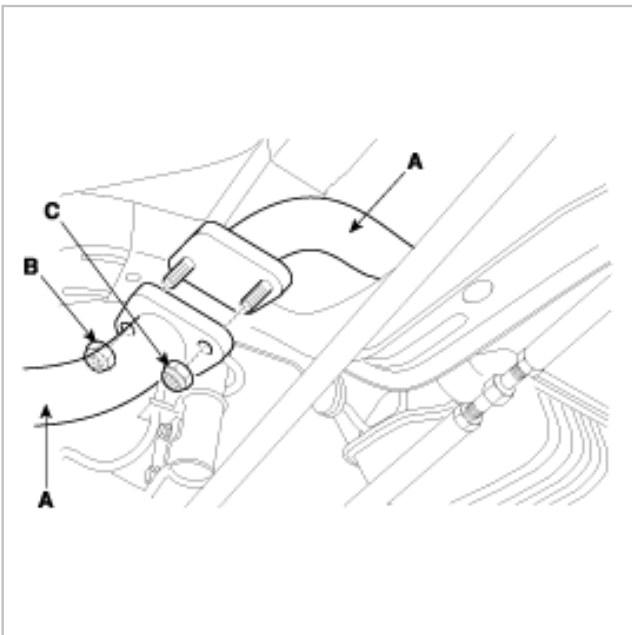

5. Remove the stabilizer bar assembly.

## INSTALLATION

1. Install the bushing on the stabilizer bar.

Ebay User ID: reveleus1

**NOTE**

After matching the bushing(D) in the inside of the white painted part(A) on the stabilizer bar(C), install the assembly.

2. Install the bracket(B) on the bushing(D).

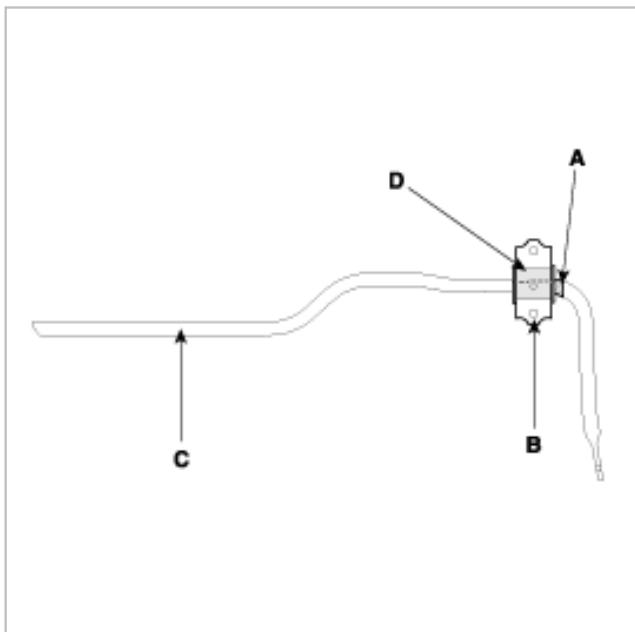

3. Tighten the components below to the specified torque as follows.

Rear stabilizer bar mounting bracket bolts (A) :

17~26 Nm (170~260 kgf-cm, 13~19 lbf-ft)

Rear stabilizer bar link mounting nut (B) :

35~45 Nm (350~450 kgf-cm, 26~33 lbf-ft)

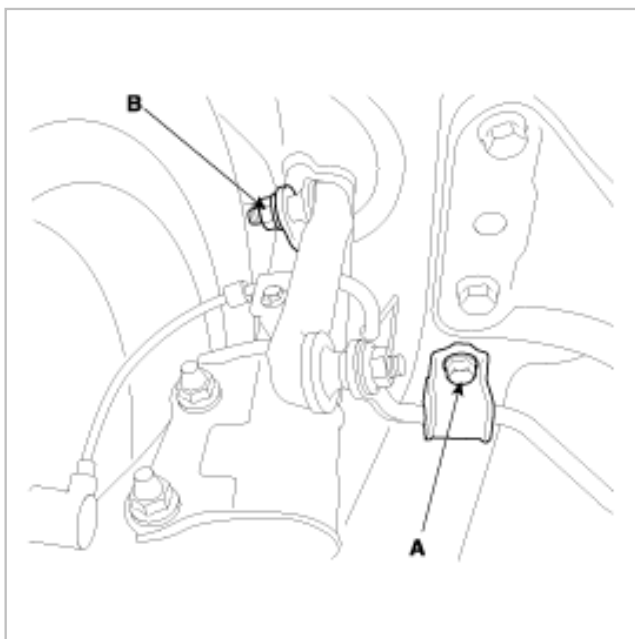

**INSPECTION**

Check the stabilizer link ball joint(A) rotating torque.

Ebay User ID: reveleus1

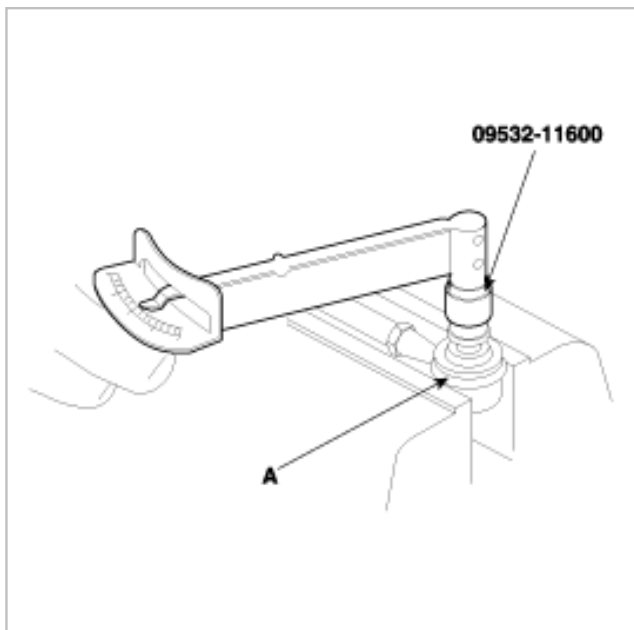

1. If there is a crack in the dust cover, replace it and add grease.
2. Shake the stabilizer link ball joint stud several times.
3. Mount the self-locking nut on the ball joint, and then measure the ball joint rotating torque.

---

**Standard value**

1.7~3.2 Nm (17~32 kgf·cm, 1.25~2.36 lbf·ft)

---

4. If the rotating torque is above the upper limit of the standard value, replace the stabilizer link.
5. If the rotating torque is below the lower limit of the standard value, the ball joint may be reused unless it has drag and excessive play.

# COMPONENTS

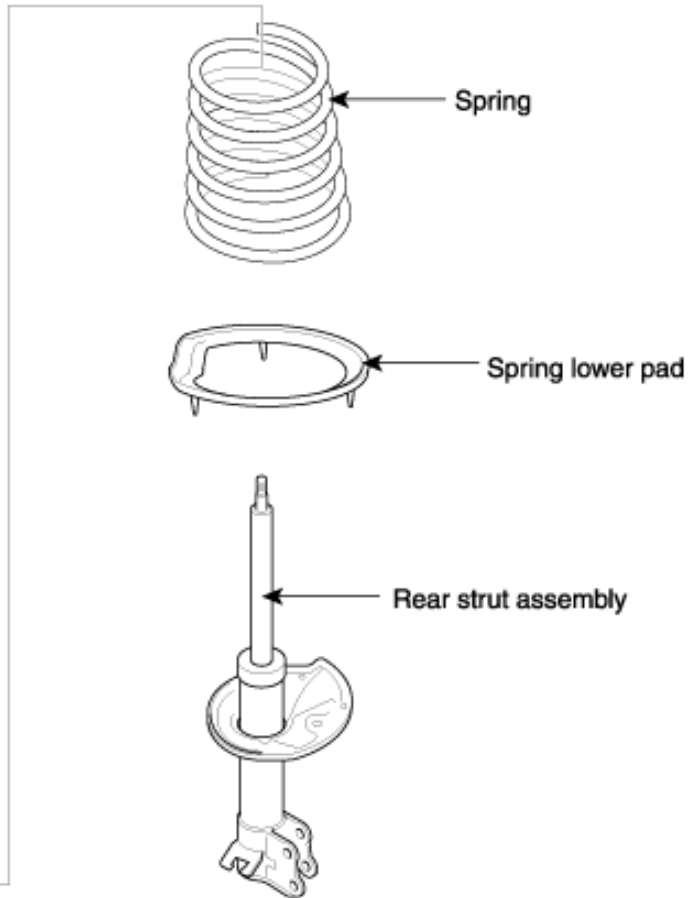
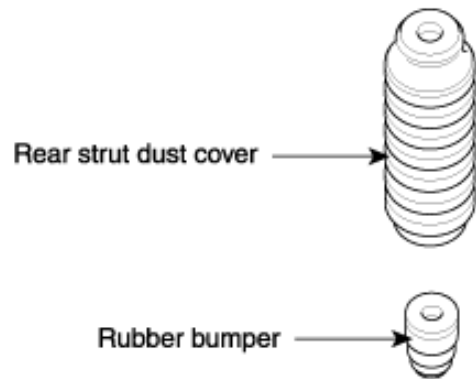
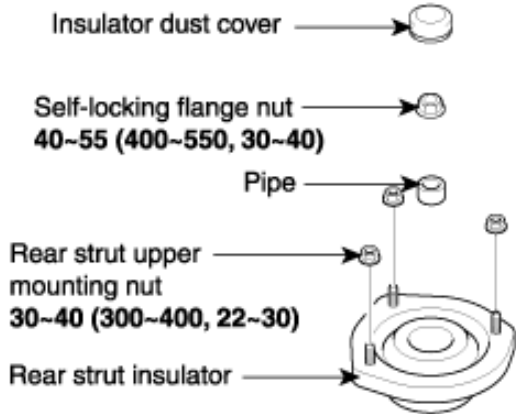
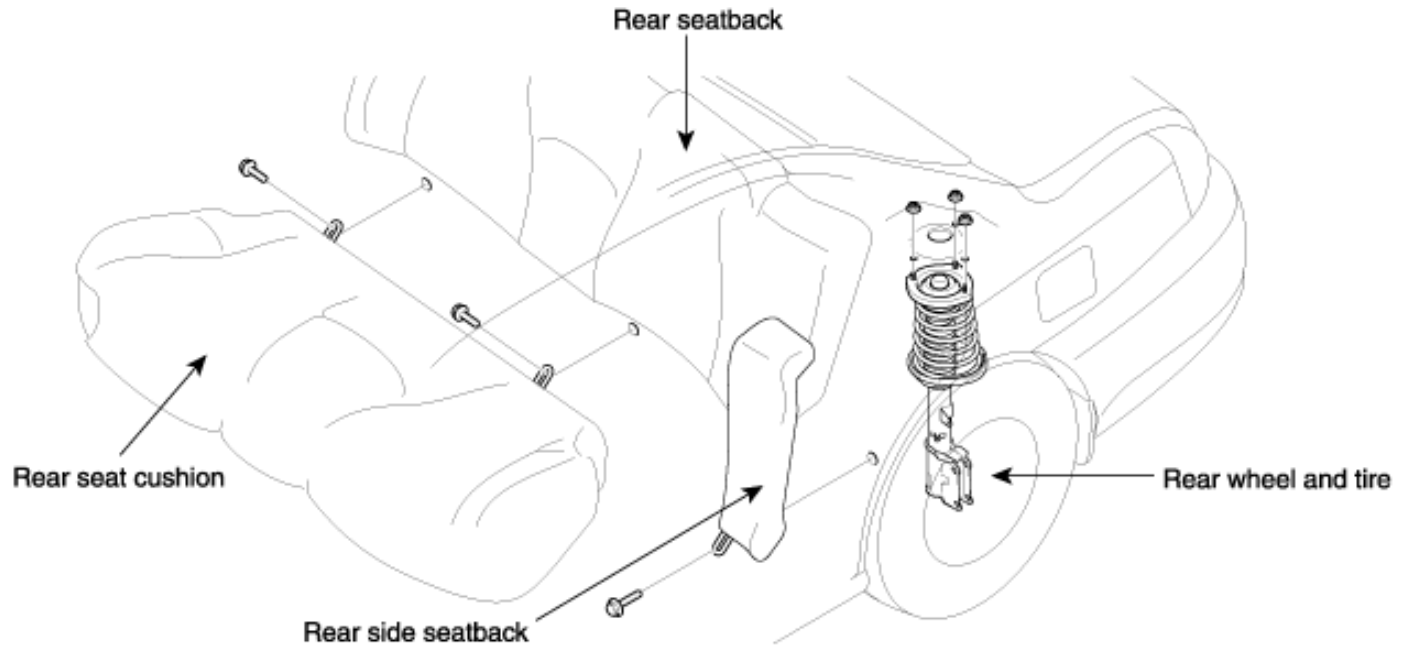

**TORQUE : N-m (kgf-cm, lbf-ft)**





## INSPECTION

1. Check the strut insulator for wear or damage.
2. Check rubber parts for damage or deterioration.
3. Check the coil spring and strut assembly for sagging and deformation.
4. Compress and extend the piston rod(A) and check that there is no abnormal resistance or unusual sound during operating.

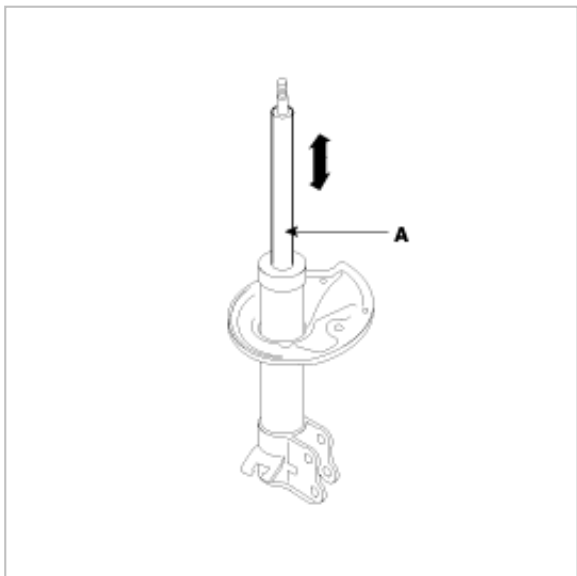

## DISASSEMBLY

1. Using the Special Tools (J38402, A-20 and A-50), compress the coil spring(A) until there is only a little tension on the strut (B).

### CAUTION

Do not use an impact gun.

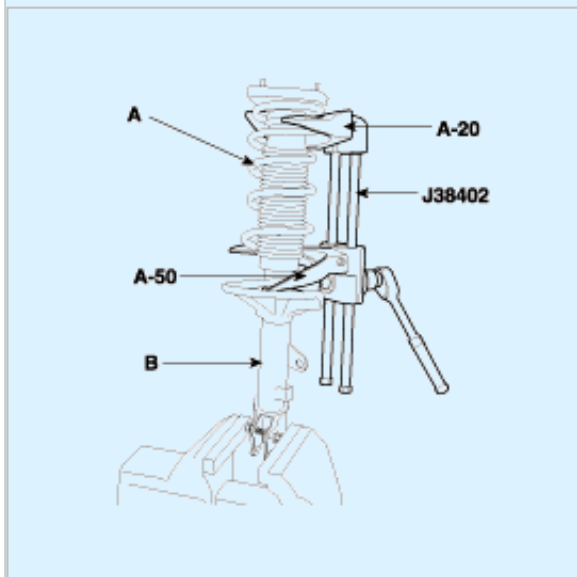

2. Open the insulator dust cover and then remove the self-locking nut at the top end of the upper strut.
3. Remove the spring upper seat, coil spring, spring lower pad, rubber bumper and dust cover.

## REASSEMBLY

1. Install the spring lower pad(D) so that the protrusions(A) fit in the holes(C) in the spring lower seat(B).

Ebay User ID: reveleus1

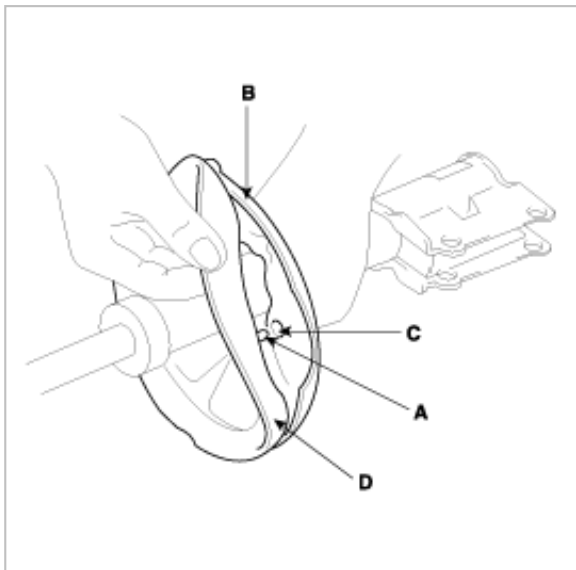

2. Install the dust cover and rubber bump at the strut.
3. Using the Special Tools (J38402, A - 20 and A - 50), compress the coil spring(A).

#### CAUTION

Do not use an impact gun.

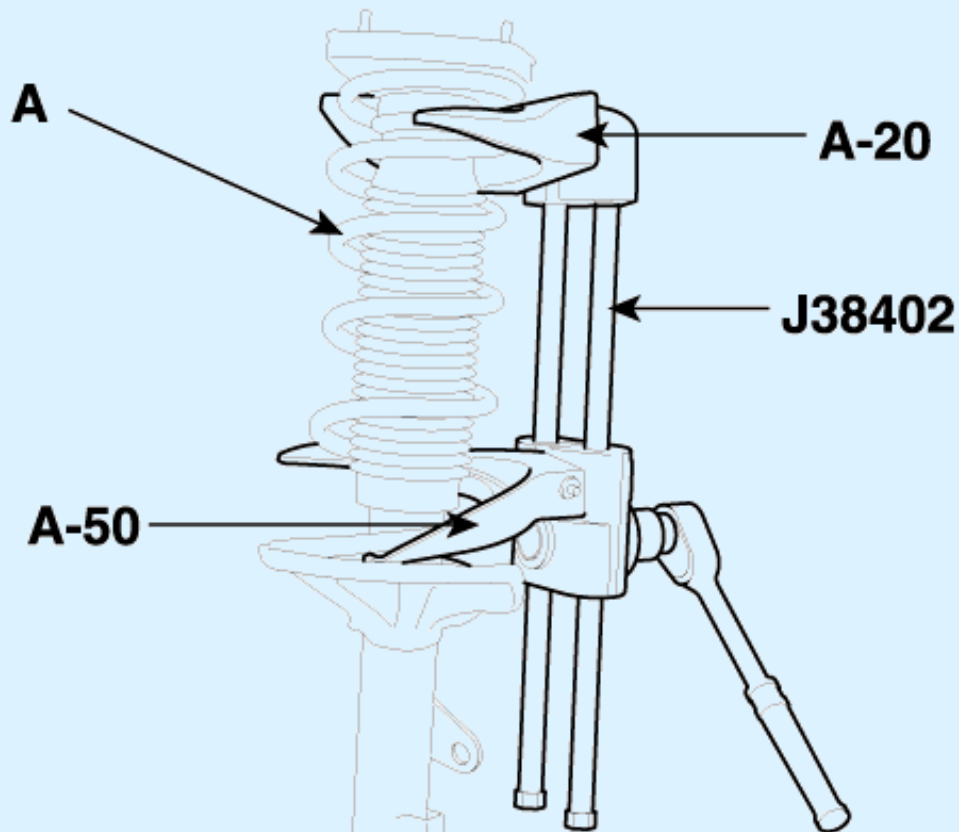



4. After extending the piston rod fully, install the compressed coil spring.
5. After seating the upper and lower ends of the coil spring in the upper and lower spring seat grooves correctly, tighten the new self-locking nut temporarily.

#### CAUTION

Replace the self-locking nut with new ones after removal.

6. After aligning the hole(A) of the lower spring seat with projection part(B) of the rear insulator, assemble them.

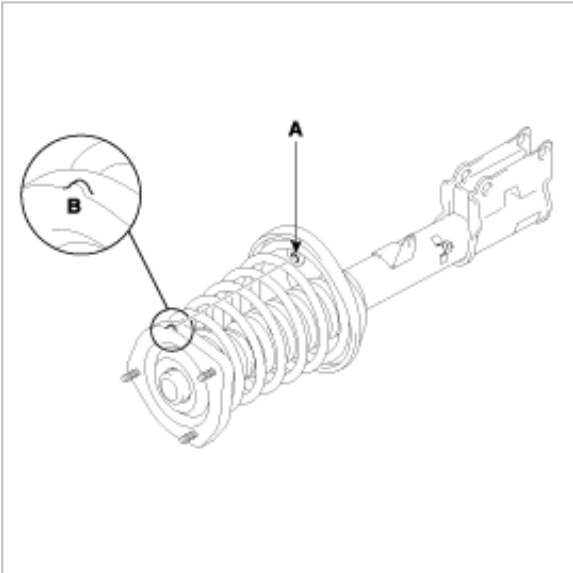

#### NOTE

The spring identification color mark should face down.

7. Remove the Special tool (J38402, A-20 and A-50).
8. Tighten the self-locking nut to the specified torque.

#### Tightening torque

40~55 Nm (400~550 kgf.cm, 29.6~40.7 lbf.ft)

## REMOVAL

1. Remove the rear seat (See BD group - rear seat).
  - (1) Raise the rear cushion.
  - (2) Remove the mounting bolts between rear cushion and rear seatback.
  - (3) Remove the mounting bolts to both end part of rear seatback.

Purchased  
from Ebay seller  
Reveleus1

Thank-you for purchasing from me, it  
is much appreciated.

To contact me please email  
[suzlever@gmail.com](mailto:suzlever@gmail.com)

2. Remove the rear strut upper mounting nuts(A).

Ebay User ID: reveleus1

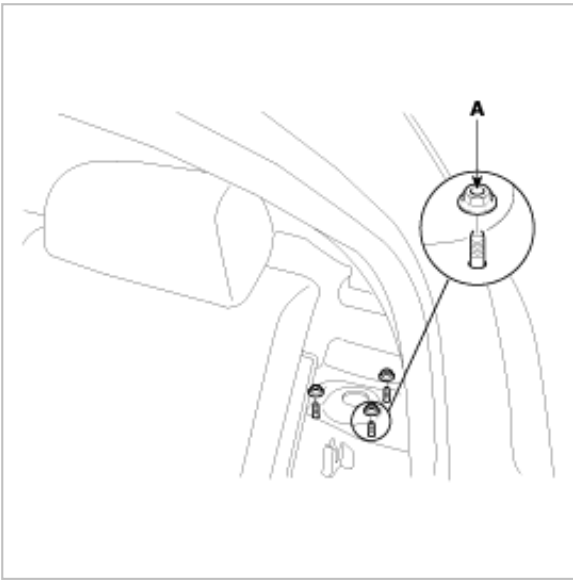

3. Remove the rear wheel and tire.

4. Disconnect the brake hose(B) and wheel speed sensor wiring(C) from the rear strut(A).

(1) Disconnect the brake hose(B) by removing the clip(D)

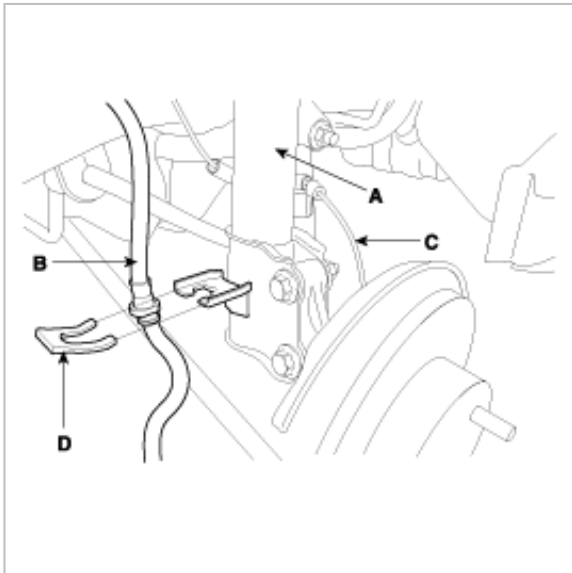

(2) Disconnect the wheel speed sensor wiring(A).

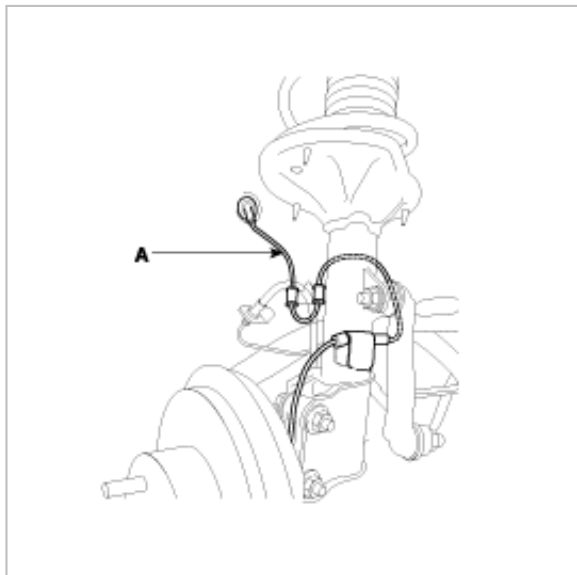

5. After unfastening stabilizer bar link nut(C), remove the stabilizer bar link(B) from the strut(A).

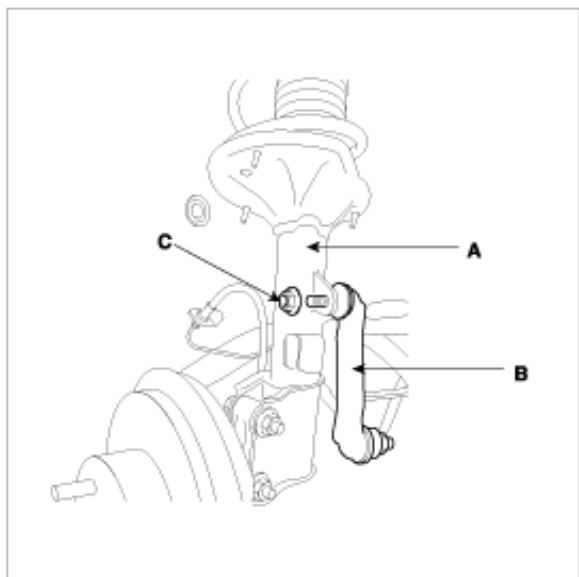

6. Remove the lower strut mounting bolts(A).

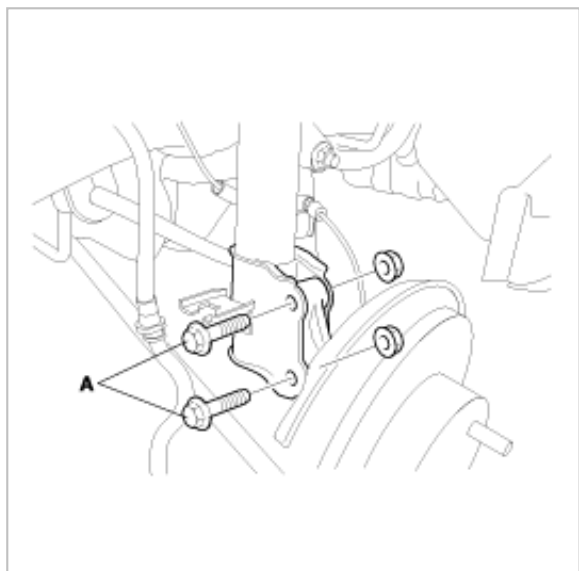

**CAUTION**

Be careful not to drop the rear strut.

7. Remove the rear strut assembly.

Ebay User ID: reveleus1

## COMPONENTS

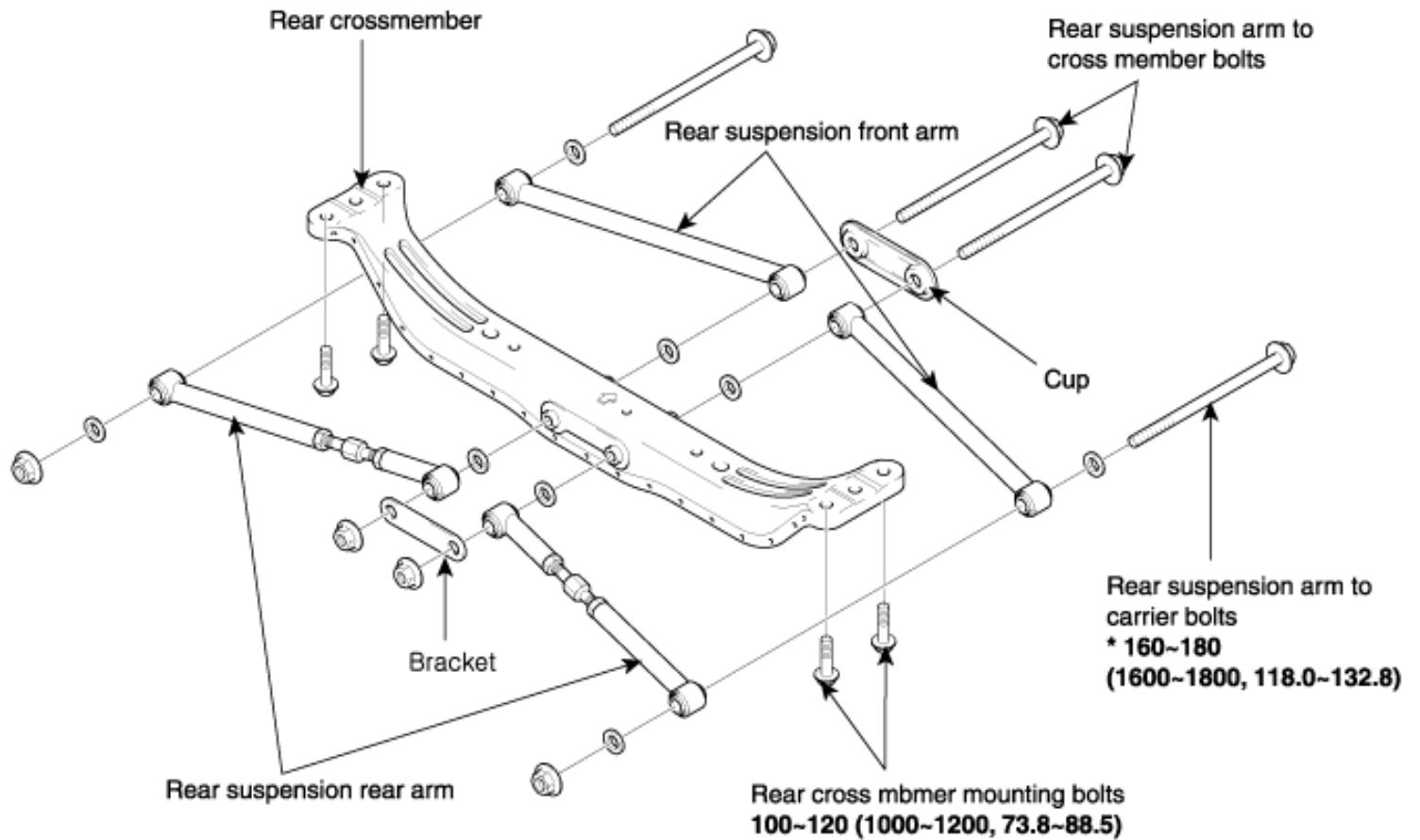

### CAUTION

The parts marked "\*" should be temporarily tightened, and then fully tightened with the vehicle on the ground in unloaded condition.

**TORQUE : N·m (kgf·cm, lbf·ft)**



## REMOVAL

1. Remove the bolt (C) fixing the trailing arm (A) to the rear carrier (B).

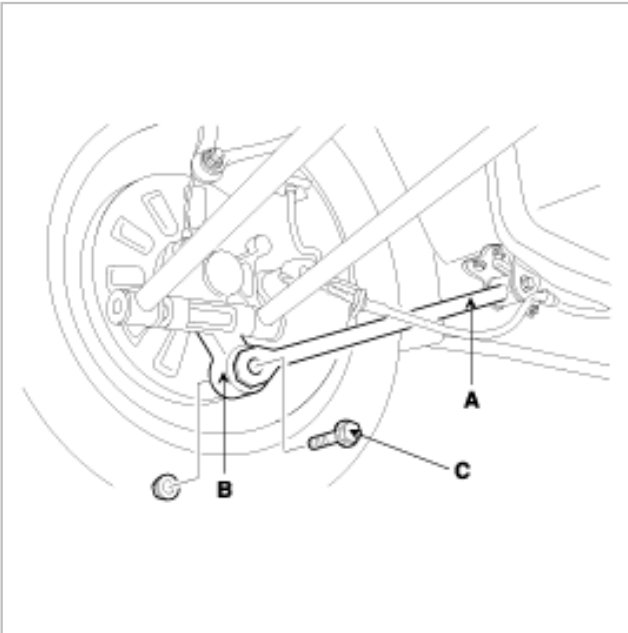

2. Remove the bolt (C) fixing the rear suspension arm (A) to the rear carrier (B).

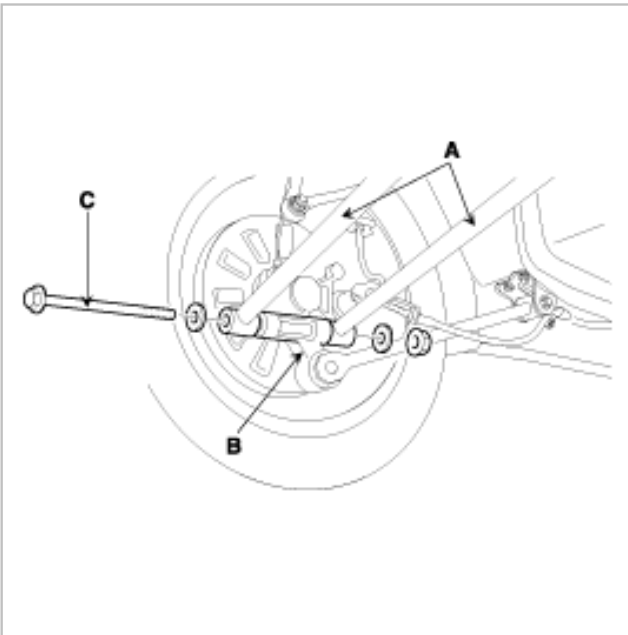

3. Employ the same manner described above step 1 and step 2 to the other side.

4. After supporting the rear cross member assembly (B) with a jack (A), remove the two cross member fixing bolts (C). Employ the same manner described above to the other side.

### CAUTION

The rear cross member assembly (B) is unstable on the jack(A); be careful not to allow it to fall.

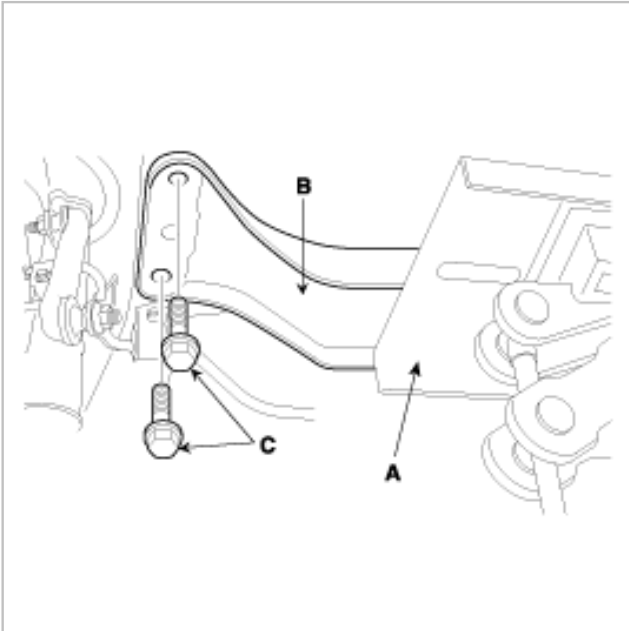

5. Lowering the jack, remove the rear cross member and rear suspension arms as an assembly.  
6. Remove the two rear suspension arm-to-cross member bolts (A, B).

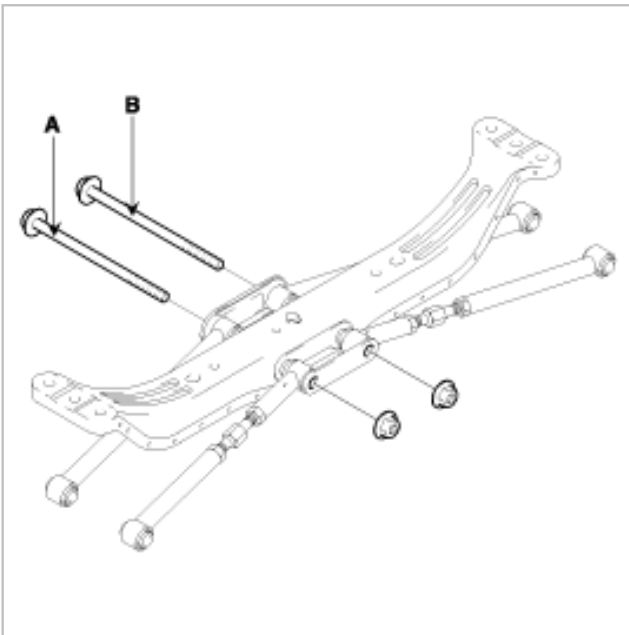

7. Remove the rear suspension arms.

## INSTALLATION

1. Installation is in the reverse order of removal (See page SS-52).



2. Reassemble the rear suspension arms (C) and the rear cross member (A) as shown below. Make sure that the arrow mark (B) on the rear cross member (A) should place the front face of the vehicle.



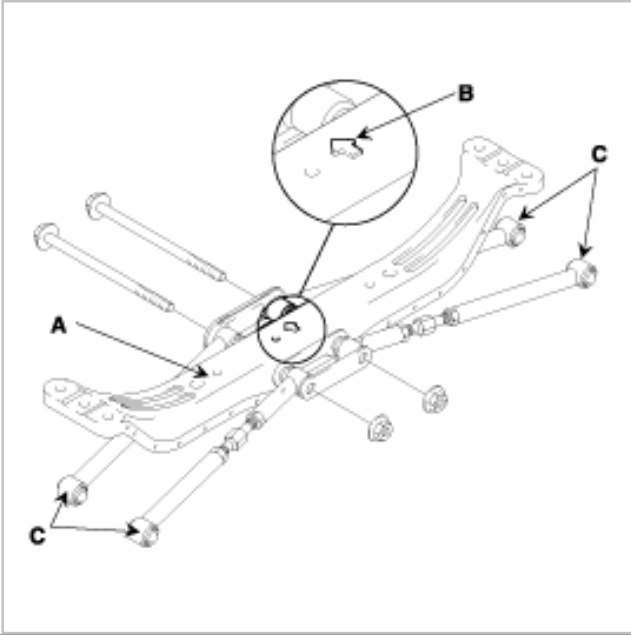

Ebay User ID: reveleus1

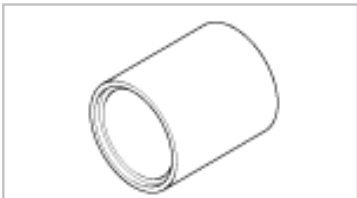
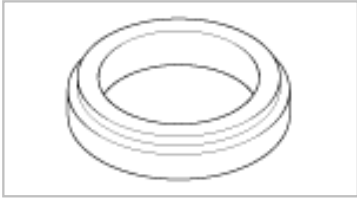
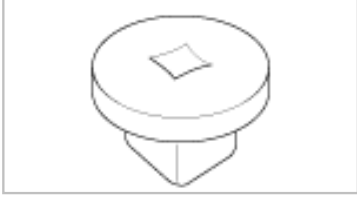
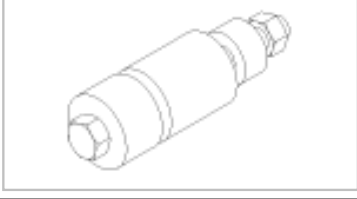
Rear suspension arm (C) -to-rear carrier bolts should be temporarily tightened, and then fully tightened with the vehicle on the ground in unloaded condition.

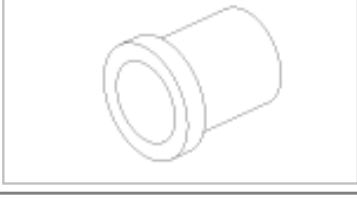

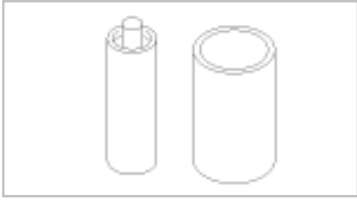
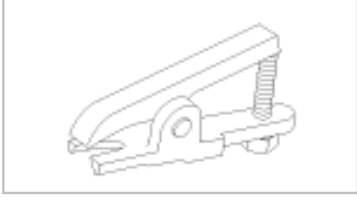
## SPECIAL TOOLS

Tool (Number and Name)	Use	Illustration
09216-21000 Mount bushing remover and installer		Removal & installation of lower arm bushing (G) (Use with 09216-21200, 09545-02000)
09216-21200 Mount bushing remover and installer base		Removal & installation of the lower arm bushing (G) (Use with 09216-21100, 09545-02000)
09532-11600 Preload socket		Measurement of the lower arm ball joint & stabilizer link starting torque
09545-02000 Lower arm bushing remover and installer		Removal & installation of the lower arm bushing (G) (Use with 09216-21100, 09216-21200)
09545-11000 Ball joint remover and installer		Installation of the lower arm ball joint
09545-21100 Ball joint dust cover installer		Installation of the lower arm ball joint dust cover

<p>09551-25000 Trailing arm bushing remover and installer</p>	<p>Ebay User ID: reveleus1</p> 	<p>Removal &amp; installation of the trailing arm bushing</p>
<p>09551-25000 Rear suspension arm remover and installer</p>		<p>Removal &amp; installation of the rear suspension arm bushing (Use with 09545-28100)</p>
<p>09568-34000 Ball joint puller</p>		<p>Separation of the lower arm ball joint</p>
<p>A-20 Strut compressor adapter</p>		<p>Compression of the rear coil spring (Use with J38402)</p>
<p>A-50 Strut compressor adapter</p>		<p>Compression of the front coil spring (Use with J38402)</p>
<p>J38402 Strut spring compressor</p>		<p>Compression of the front &amp; rear coil spring (Use with A-50 or A-20)</p>



## SPECIFICATIONS

### Front suspension system

### Macpherson strut type

#### Shock absorber

Type	Gas type
Stroke mm (in)	163.8 (6.45)
Damping force at 0.3 m/s	
Expansion N(kg)	1120 ± 170 (112 ± 17)
Compression N(kg)	260 ± 60 (26 ± 6)
I.D color	White

#### Coil spring free height and identification color

Model	Free height mm (in.)	I.D color
2.0 GL M/T (N-A/CON) 2.0 GLS M/T (N-A/CON)	335.0 (13.19)	Blue - 1
2.0 GL M/T (A/CON) 2.0 GL A/T (N-A/CON) 2.0 GLS M/T (A/CON)	344.4 (13.56)	Green - 1
2.0 GL A/T (A/CON) 2.0 GLS A/T (ALL)	354.0 (13.94)	Violet - 1

- \* GL, GLS : Trim level
- \* M/T : With manual T/A
- \* A/T : With automatic T/A
- \* A/CON : With air conditioning
- \* N-A/CON : Non-air conditioning
- \* CBS : With conventional brake system

**Rear suspension system**Ebay User ID: 1076166154 **Dual link****Shock absorber**

Type	Gas type
Stroke mm (in)	203.7 (8.02)
Damping force at 0.3 m/s	
Expansion N(kg)	510 ± 90 (21 ± 9)
Compression N(kg)	210 ± 50 (21 ± 5)
I.D color	White

**Coil spring free height and identification color**

Model	Free height mm (in.)	I.D color
4DR (ALL)	349.5 (13.76)	Blue - 1

**SERVICE STANDARD****FRONT WHEEL ALIGNMENT**

Items	Standard value
Camber angle	0° ± 30'
Caster angle (To ground)	2°49' ± 30'
Toe in	4 +3/-1mm
Kingpin angle	12°10' ± 30'
Kingpin offset	-1.0 mm
Side slip (when going forward 1m)	IN : 3mm(0.12 in.), OUT : 3mm(0.12 in.)
Tread	1485mm (58.46 in.)

**NOTE**

Difference between left and right camber angle is within 0°30'.

Difference between left and right caster angle is also within 0°30'.

**REAR WHEEL ALIGNMENT**

Items	Standard value
Camber angle	-55' ± 30'
Toe in (Tire outer diameter 602mm)	LH/RH(each) : 2.5±1mm (0.1±0.04 in.) TOTOAL : 3~7mm (0.12 in.)
Thrust angle	0° ± 0.15°
Side slip (When going forward 1m)	2~9 mm (0.08~0.35 in.)
Tread	1475 mm (58.07 in.)

Difference between left and right camber angle is within 0° 30'.

**TIRE**

Items	Standard value
Size	195/60 R15, T125/70 D15 (Temporary tire)
Inflation pressure kg·cm <sup>2</sup> (psi)	2.1 <sup>+0.07</sup> <sub>0</sub> (30 <sup>+1</sup> <sub>0</sub> ), 4.2(60) : Temporary tire
Runout	
Radial mm(in)	1.5 (0.059)
Lateral mm (in)	1.5 (0.059)

**WHEEL**

Items	Standard value	
Size	5.5J x 15	
Runout	Radial	Lateral
Steel wheel mm(in.)	0.5 (0.02)	0.8 (0.03)
Aluminum mm(in.)	0.3 (0.01)	0.3 (0.01)

**TIGHTENING TORQUE**

Items	Nm	kgf·cm	lbf·ft
Wheel nut	90 ~ 110	900 ~ 1100	67 ~ 82
Castle nut	200 ~ 260	2000 ~ 2600	159 ~ 192
Front strut upper mounting nut	45 ~ 60	450 ~ 600	33 ~ 44
Front strut assembly to knuckle	130 ~ 150	1300 ~ 1500	96 ~ 111
Front strut mounting self-locking nut	50 ~ 70	500 ~ 700	37 ~ 51
Lower arm ball joint to knuckle	60 ~ 72	600 ~ 720	43 ~ 52
Lower arm bush (A) mounting bolt	130 ~ 150	1300 ~ 1500	96 ~ 111
Lower arm bush (G) mounting bolt	130 ~ 150	1300 ~ 1500	96 ~ 111
Stabilizer bar bracket mounting bolt	30 ~ 45	300 ~ 450	22 ~ 33
Stabilizer link nut	35 ~ 45	350 ~ 450	26 ~ 33
Tie rod end ball joint to knuckle	24 ~ 34	240 ~ 340	18 ~ 25
Tie rod end lock nut	50 ~ 55	500 ~ 550	37 ~ 41
Rear strut upper mounting nut	30 ~ 40	300 ~ 400	22 ~ 30
Rear strut lower mounting nut	110 ~ 130	1100 ~ 1300	81 ~ 96
Rear strut mounting self locking nut	40 ~ 55	400 ~ 550	29.6 ~ 40.7
Rear stabilizer link to stabilizer bar	35 ~ 45	350 ~ 450	26 ~ 33
Rear stabilizer bar bracket bolt	17 ~ 26	170 ~ 260	13 ~ 19
Rear suspension arm tie rod nut	50 ~ 60	500 ~ 600	37 ~ 43
Rear suspension arm mounting bolt	160 ~ 180	1600 ~ 1800	118 ~ 133
Rear cross member mounting bolt	100 ~ 120	1000 ~ 1200	74 ~ 88
Trailing arm to bracket nut	100 ~ 120	1000 ~ 1200	74 ~ 88
Trailing arm bracket to body frame	40 ~ 50	400 ~ 500	30 ~ 37
Trailing arm to rear carrier mounting nut	100 ~ 120	1000 ~ 1200	74 ~ 89



**CAUTION**

Ebay User ID: reveleus1

Replace the self-locking nuts with new ones after removal.

**LUBRICANTS**

Item	Recommended lubricant	Quantity
In ball joint of lower arm	Variant R-2 grease or poly lub gly 801K	As required
In insulator bearing of strut	SAE J310a, Chassis grease (NLGI No.0 or equivalent)	As required

# COMPONENTS

[ Trailing arm location ]

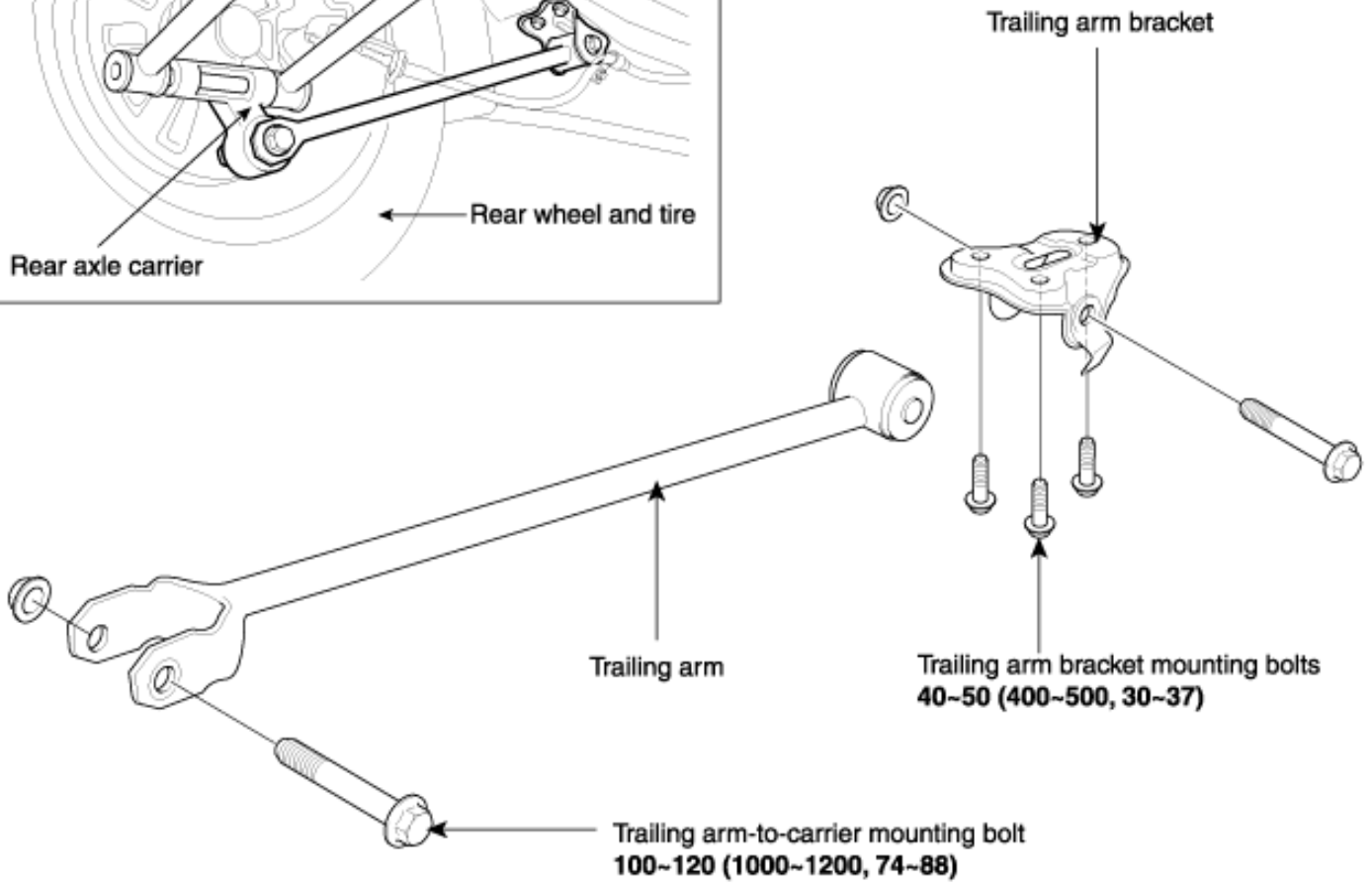
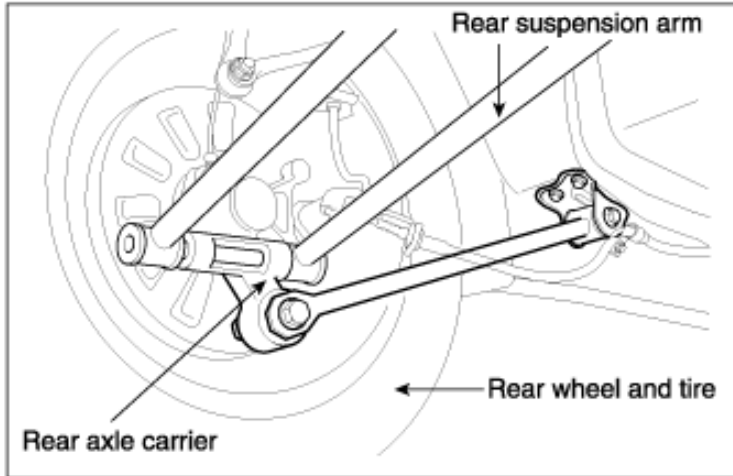

**TORQUE : N·m (kgf·cm, lbf·ft)**

## REMOVAL

1. After removing the bolt (C), detach the parking brake cable(B) which is fixed on the rear trailing arm bracket(A).

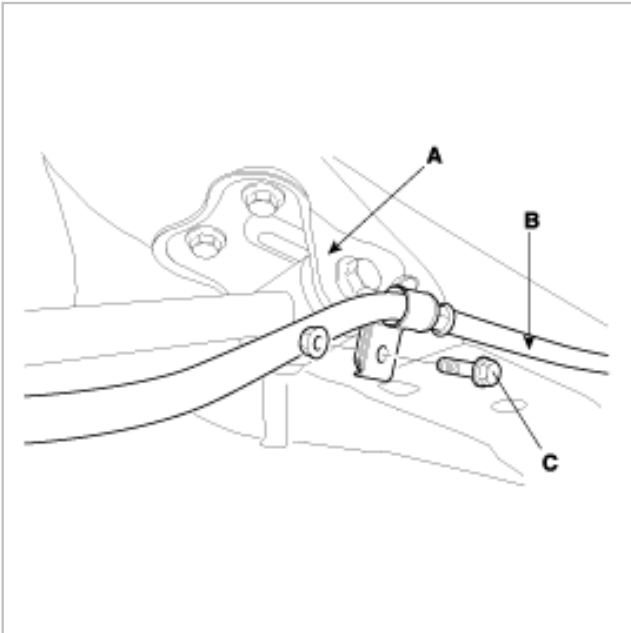

2. Remove the trailing arm mounting bolts(A,B) and the trailing arm bracket mounting bolts(C,D,E).

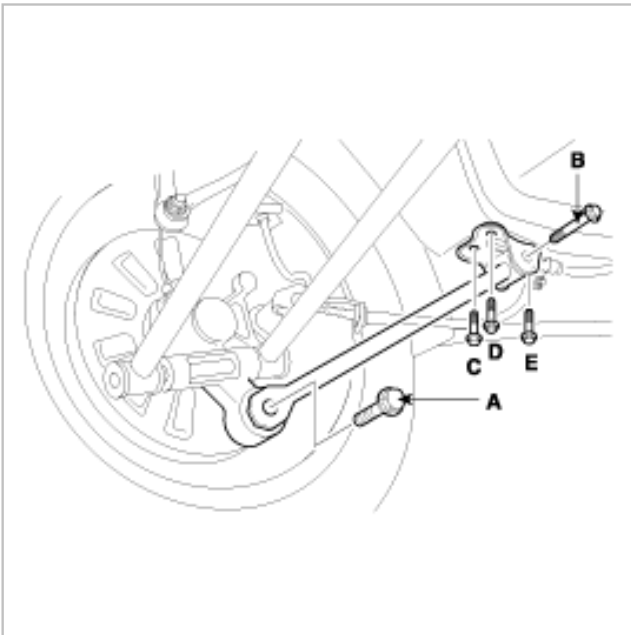

3. Remove the trailing arm.

## REPLACEMENT

### TRAILING ARM BUSHING

1. Install the special tool (09551 - 25000) on the trailing arm(A).  
Ebay User ID: reveleus1

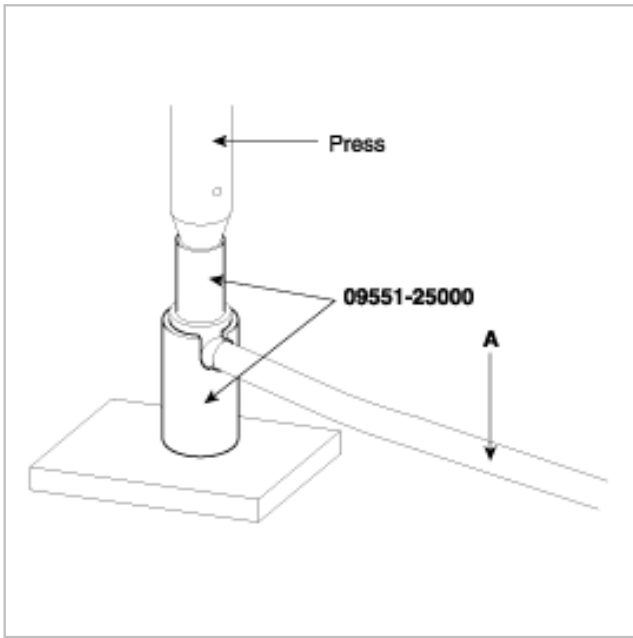

2. Remove the trailing arm bushing.  
3. Using the special tool (09551 - 25000), press-fit the rear trailing arm bushing.

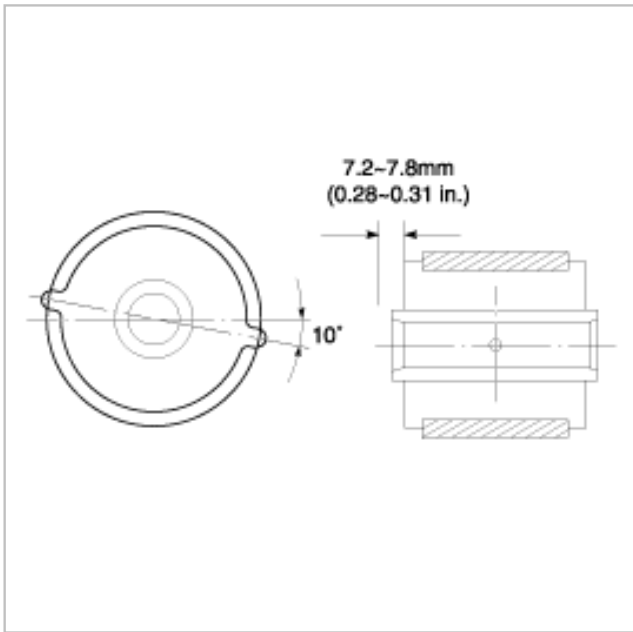

#### NOTE

Press-fit the bushing in the same way as shown in the illustration.

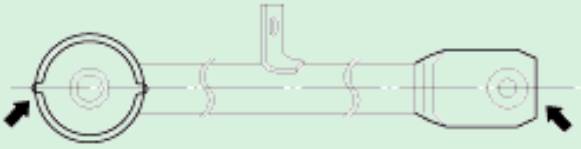

## INSTALLATION

1. Installation is the reverse of the removal procedures.
2. Fully tighten the trailing arm mounting bolts to the specified torque under the unloaded vehicle on the ground.



## TROUBLESHOOTING

### Vehicle inspection

To assist the service advisor and the technician, check the suspension and wheel/tire condition with the questions listed below by filling them. It serves as a place to record information as well as data from the testing to be carried out. To begin a successful diagnosis, fill out the questions.

#### WHEEL/TIRE/CHECK :

Balance Check **Yes / No**

Maximum Runout Allowed :

Wheel : Radial \_\_\_\_\_ Lateral \_\_\_\_\_

Tire : Radial \_\_\_\_\_ Lateral \_\_\_\_\_

Measured Runout :

Tire/Wheel Radial : LF \_\_\_\_\_ LR \_\_\_\_\_ RF \_\_\_\_\_ RR \_\_\_\_\_

Lateral : LF \_\_\_\_\_ LR \_\_\_\_\_ RF \_\_\_\_\_ RR \_\_\_\_\_

Wheel Only Radial : LF \_\_\_\_\_ LR \_\_\_\_\_ RF \_\_\_\_\_ RR \_\_\_\_\_

Lateral : LF \_\_\_\_\_ LR \_\_\_\_\_ RF \_\_\_\_\_ RR \_\_\_\_\_

#### SUSPENSION INSPECTION :

Can Cause Shimmy  Clunk  Squeak  Harshness

Suspension Bushing : Loose  Worn  Missing  OK

Front stabilizer  Rear stabilizer (sway bar)  Rear trailing arm

Front lower arm  Rear suspension front  Rear suspension rear arm

Other \_\_\_\_\_

Suspension/Components : Loose Worm Missing OK

Ball Joint  Shock absorbers F/R  Springs F/R  The rod ends/sleeve

### SYMPTOM CHART

Symptom	Suspect Area	Remedy (See page)
Squeak or grunt-noise from the front suspension, occurs more in cold ambient temperatures-more noticeable over rough roads or when turning	Front stabilizer bar	Under these conditions, the noise is acceptable.
Clunk-noise from the front suspension, occurs in and out of turns	Loose front struts or shocks	Inspect for loose nuts or bolts. Tighten to specifications. See page SS-27.

Clunk-noise from the rear suspension, occurs when shifting from reverse to drive	Loose rear suspension components Ebay User ID: revereus1	Inspect for loose or damaged rear suspension components. Repair or install new components as necessary. See page SS-44.
Click or pop-noise from the front suspension-more noticeable over rough roads or over bumps	Worn or damaged ball joints	Install new lower arm as necessary. See page SS-34.
Click or pop-noise occurs when vehicle is turning	Worn or damaged ball joints	Install new lower arm as necessary. See page SS-35.
Click or snap-occurs when accelerating around a corner	Damaged or worn Birfield joint	Repair or install a new Birfield joint as necessary. See DS group - driveshaft.
Front suspension noise-a squeak, creak or rattle noise-occurs mostly over bumps or rough roads	Steering components Loose or bent front struts or shock absorbers Damaged spring or spring mounts Damaged or worn arm bushings Worn or damaged stabilizer bar bushing or links	Go to detailed test A. See page SS-12.
Groaning or grinding-noise from the front strut, occurs when driving on bumpy roads or turning the vehicle	Uneven seating surface between the insulator and panel by the burrs around the strut insulator mounting bolts and the insulator boltes mounting holes	Repair or install a new parts as necessary. See page SS-28.
Rear suspension noise - a squeak, creak or rattle noise - occurs mostly over bumps or rough roads	Loose or bent rear shock absorbers Damaged spring or spring mounts Damaged or worn control arm bushings	Go to detailed test B. See page SS-13.
Shudder-occurs during acceleration from a slow speed or stop	Rear axle assembly mispositioned Damaged or worn front suspension components	Check the axle mounts and Rear suspension the rear suspension for damage or wear. Repair as necessary. Check for a loose stabilizer bar, damaged or loose strut/strut bushings or loose or worn ball joints. Inspect the steering linkage for wear or damage. Repair or Install new components as necessary.
Shimmy-most noticeable on coast/ deceleration-also hard steering condition	Excessive positive caster	Check the caster alignment angle. Correct as necessary. See page SS-58.

Tire noise-hum/moan at constant speeds	Abnormal wear patterns Ebay User ID: reveleus1	Spin the tire and Check for tire wear. Install a new tire as necessary. Inspect for damaged/worn suspension components. Carry out wheel alignment. See page SS-58, SS-62.
Tire noise-noise tone lowers as the vehicle speed is lowered	Out-of-balance tire	Balance the tire and road test. Install a new tire as necessary. See page SS-62.
Tire noise - ticking noise, change with speed	Nail puncture or stone in tire tread	Inspect the tire. Repair as necessary. See page SS-62.
Wheel and tire-vibration and noise concern is directly related to vehicle speed and is not affected by acceleration, coasting or decelerating	Damaged or worn tire	Go to detailed test C. See page SS-14.
Tire wobble or shudder - occurs at lower speeds	Damaged wheel bearings	Spin the tire and check for abnormal wheel bearing play or roughness. Adjust or Install new wheel bearings as necessary. See DS group - front/rear axle.
	Damaged wheel	Inspect the wheel for damage. Install a new wheel as necessary. See page SS-60.
	Damaged or worn suspension components	Inspect the suspension components for wear or damage. Repair as necessary. See page SS-27, SS-44.
	Loose wheel nuts	Check the wheel nuts. Tighten to specification. See page SS-60.
	Damaged or uneven tire wear	Spin the tire and Check for abnormal tire wear or damage. Install a new tire as necessary. See page SS-62
Tire shimmy or shake - occurs at lower speeds	Wheel/tire out of balance	See page SS-58.
	Uneven tire wear	Check for abnormal tire wear. Install a new tire as necessary. See page SS-62.



	Excessive radial runout of wheel or tire <small>Ebay User ID: reveleus1</small>	Carry out a radial runout test of the wheel and tire. Install a new tire as necessary. See page SS-60.
	Worn or damaged wheel studs or elongated stud holes	Inspect the wheel studs and wheels. Install new components as necessary. See page SS-60.
	Excessive lateral runout of the wheel or tire	Carry out a lateral runout test of the wheel and tire. Check the wheel, tire and hub. Repair or Install new components as necessary. See page SS-60.
	Foreign material between the brake disc and hub.	Clean the mounting surfaces of the brake disc and hub. See DS group - front/rear axle.
High speed shake or shimmy-occurs at high speeds	Excessive wheel hub runout Damaged or worn tires Damaged or worn wheel bearings Worn or damaged suspension or steering linkage Brake disc or drum imbalance	Go to detailed test D. See page SS-17.
Drift left or right	Tires Steering linkage Alignment Base brake system	Go to detailed test E. See page SS-19.
Steering wheel	Alignment Steering linkage Front lower arm ball joint	Go to detailed test F. See page SS-20.
Tracks incorrectly	Rear suspension Caster	Go to detailed test G. See page SS-21.
Rough ride	Front strut and spring assembly Rear shock absorber and spring assembly	Go to detailed test H. See page SS-22.
Excessive noise	Front or rear stabilizer bar components Springs Suspension components Shock absorbers	Go to detailed test I. See page SS-22.

Incorrect tire wear	Tire or unbalanced wheels Tire inflation Strut Alignment	Go to detailed test J. See page SS-23.
Vibration	Wheel/tire Front wheel drivshaft(s) Steering system Strut and spring assembly Spring and strut mounting Front lower arm ball joint Front lower arm mounting bolt bushing Stabilizer bar bushings Wheel hubs and bearing Rear suspension arms and bushings	Go to detailed test K. See page SS-24.
Vehicle leans	Tire/wheel Vehicle load Suspension components Incorrect ride height	Inflate tires to specification. See page SS-62. Redistribute the load as necessary. Visually inspect the suspension system Correct the ride height as necessary
Poor returnability	High knuckle rotating torque Alignment	Go to detailed test E. See page SS-19.

#### DETAILED TEST A : FRONT SUSPENSION NOISE

CONDITIONS	DETAILS/RESULTS/ACTIONS
ROAD TEST THE VEHICLE	
	1. Test drive the vehicle. 2. During the road test, drive the vehicle over a rough road. Determine from which area/component the noise is originating. ● Is there a squeak, creak or rattle noise ? → <b>YES</b> . → <b>NO</b> The suspension system is OK. Conduct a diagnosis on other suspect systems.
INSPECT THE STEERING SYSTEM	

1. Check the steering system for wear or damage.  
 Carry out a steering linkage test.

2. Inspect the tire wear pattern. See page SS-26.

● Are the steering components worn or damaged ?  
 → **YES**  
 Repair the steering system. Install new components as necessary. Test the system for normal operation

→ **NO**  
 Go to

**FRONT SHOCK ABSORBER/STRUT CHECK**

1. Check the front shock absorbers/strut mounts for loose bolts or nuts.

2. Check the front shock absorbers/struts for damage. Carry out a shock absorber check.

● Are the front shock absorbers/struts loose or damaged ?  
 → **YES**  
 Tighten to specifications if loose.  
 Install new front shock absorbers/struts if damaged. Test the system for normal operation.

→ **NO**  
 Go to

**CHECK THE FRONT SPRINGS**

Check the front spring and front spring mounts/brackets for wear or damage

● Are the front springs or spring mounts/brackets worn or damaged ?  
 → **YES**  
 Repair or Install new components as necessary. Test the system for normal operation.

→ **NO**  
 Go to **A5**.

**CHECK THE STABILIZER BAR**

1. Check the stabilizer bar bushing and links for damage or wear.

2. Check the stabilizer bar for damage.

3. Check for loose or damaged stabilizer brackets.

● Are the stabilizer bar/track bar components loose, worn or damaged ?  
 → **YES**  
 Repair or Install new components as necessary. Test the system for normal operation.

→ **NO**  
 Suspension system is OK. Conduct diagnosis on other suspect systems.

CONDITIONS	DETAILS/RESULTS/ACTIONS
ROAD TEST THE VEHICLE	<p>1. Test drive the vehicle.</p> <p>2. During the road test, drive the vehicle over a rough road. Determine from which area/component the noise is originating.</p> <p>● Is there a squeak, creak or rattle noise ?</p> <p>→ <b>YES</b></p> <p>Go to</p> <p>→ <b>NO</b></p> <p>The suspension system is OK. Conduct a diagnosis on other suspect systems.</p>
REAR SHOCK ABSORBER/STRUT CHECK	<p>1. Raise and support the vehicle. See GI group - lift support point.</p> <p>2. Check the rear shock absorber/strut mounts for loose bolts or nuts.</p> <p>3. Check the rear shock absorbers/strut for damage. Carry out a shock absorber check.</p> <p>● Are the rear shock absorbers/struts loose or damaged ?</p> <p>→ <b>YES</b></p> <p>Tighten to specifications if loose.</p> <p>Install new rear shock absorbers/struts if damaged. Test the system for normal operation.</p> <p>→ <b>NO</b></p> <p>Go to</p>
CHECK THE REAR SPRINGS	<p>Check the rear springs and rear spring mounts/brackets for wear or damage.</p> <p>● Are the rear springs or spring mounts/brackets worn or damaged ?</p> <p>→ <b>YES</b></p> <p>Repair or Install new components as necessary. Test the system for normal operation.</p> <p>→ <b>NO</b></p> <p>Go to <b>B4</b>.</p>
CHECK THE TRAILING ARMS	

1. Inspect the trailing arm bushings for wear or damage. Check for loose trailing arm bolts.
2. Inspect for twisted or bent trailing arms.
  - Are the trailing arms loose, damaged or worn ?
  - **YES**
  - Repair or Install new components as necessary. Test the system for normal operation.
  - **NO**
  - Suspension system is OK. Conduct diagnosis on other suspect systems.

**DETAILED TEST C : WHEEL AND TIRE**

CONDITIONS	DETAILS/RESULTS/ACTIONS
ROAD TEST THE VEHICLE	
	<div style="background-color: #e0ffe0; padding: 5px; border: 1px solid #ccc;"> <p style="text-align: center; margin: 0;"><b>NOTE</b></p> <p>Wheel or tire vibrations felt in the steering wheel are most likely related to the front wheel or tire. Vibration felt through the seat are most likely related to the rear wheel or tire. This may not always be true, but it can help to isolate the problem to the front or rear of the vehicle.</p> <p>Test drive the vehicle at different speed ranges.</p> </div> <p>During the road test, if the vibration can be eliminated by placing the vehicle in neutral or is affected by the speed of the engine, the cause is not the wheels or tires.</p> <ul style="list-style-type: none"> <li>● Is there a vibration and noise ?</li> <li>→ <b>YES</b></li> <li>Go to<b>C2</b>.</li> <li>→ <b>NO</b></li> <li>The wheel and tires are OK. Conduct a diagnosis on other suspect systems.</li> </ul>
CHECK THE FRONT WHEEL BEARINGS	
	<p>Check the front wheel bearings.</p> <p>Refer to Wheel Bearing Check (See DS group - front axle).</p> <ul style="list-style-type: none"> <li>● Are the wheel bearing OK ?</li> <li>→ <b>YES</b></li> <li>Go to<b>C3</b>.</li> <li>→ <b>NO</b></li> <li>Inspect the wheel bearings. Adjust or Repair as necessary. Test the system for normal operation.</li> </ul>
INSPECT THE TIRES	

1. Check the tires for missing weights.
2. Check the wheels for damage.
3.
  - Do the tires have an abnormal wear pattern ?
    - **YES**
    - Correct the condition that caused the abnormal wear. Install new tire(s).
    - Test the system for normal operation.
  - **NO**
  - Go to

**TIRE ROTATION DIAGNOSIS**

1. Spin the tires slowly and watch for signs of lateral runout.
2. Spin the tires slowly and watch for signs of radial runout.
  - Are there signs of visual runout ?
    - **YES**
    - Go To
  - **NO**
  - Check the wheel and tire balance.
  - Correct as necessary. Test the system for normal operation.

**RADIAL RUNOUT CHECK ON THE TIRE**

Measure the radial runout of the wheel and tire assembly. A typical specification for total radial runout is 1.15mm (0.059 inch).

- Is the radial runout within specifications ?
  - **YES**
  - Go to **C8**.
- **NO**
- Go to **C6**.

**RADIAL RUNOUT CHECK ON THE WHEEL**

Measure the radial runout of the wheel. A typical specification for total radial runout is 1.14mm (0.045 inch.).

- Is the radial runout within specifications ?
  - **YES**
  - Install a new tire. Test the system for normal operation.
- **NO**
- Go to **C7**.

**CHECK THE HUB/BRAKE DISC OR DRUM PILOT RUNOUT OR BOLT CIRCLE RUNOUT**

Measure the pilot or bolt circle runout. A typical specification for radial runout is :

- pilot runout - less than 0.15mm (0.006 inch.)
- bolt circle runout - less than 0.38 mm (0.015 inch.)
- Is the radial runout within specification ?

→ **YES**

Install a new wheel. Test the system for normal operation.

→ **NO**

Repair or Install new components as necessary. See page SS-27 for the front suspension or SS-43 for the rear suspension.

**LATERAL RUNOUT CHECK ON THE TIRE**

Measure the lateral runout of the wheel and tire assembly. A typical specification for total lateral runout is 2.5mm (0.098 inch).

- Is the lateral runout within specifications ?

→ **YES**

Wheel and tires are OK. Conduct diagnosis on other suspect systems.

→ **NO**

Go to **C9**.

**LATERAL RUNOUT CHECK ON THE WHEEL**

Measure the lateral runout of the wheel. A typical specification for total radial runout is 1.2mm (0.047 inch.)

- Is the lateral runout within specifications ?

→ **YES**

Install a new tire. Test the system for normal operation.

→ **NO**

Go to **C10**.

**CHECK THE FLANGE FACE LATERAL RUNOUT**

Measure the flange face lateral runout. A typical specification for lateral runout is :

- hub/brake disc - less than 0.13mm (0.005 inch)
- Is the lateral runout within specifications ?

→ **YES**

Install a new wheel. Test the system for normal operation.

→ **NO**

Repair or Install new components as necessary. See page SS-27 for the front suspension or SS-44 for the rear suspension.

**DETAILED TEST D : HIGH SPEED SHAKE OR SHIMMY**

CONDITIONS	DETAILS/RESULTS/ACTIONS
CHECK FOR FRONT WHEEL BEARING ROUGHNESS	

1. See G1 group, - lift support point.

2. Spin the front tires by hand.

● Do the wheel bearings feel rough ?

→ **YES**

Inspect the wheel bearings. Repair as necessary. Test the system for normal operation.

→ **NO**

Go to

### CHECK THE END PLAY OF THE FRONT WHEEL BEARINGS

Check the end play of the front wheel bearings.

● Is the end play OK ?

→ **YES**

Go to **D3**.

→ **NO**

Adjust or Repair as necessary. Test the system for normal operation.

### MEASURE THE LATERAL RUNOUT AND THE RADIAL RUNOUT OF THE FRONT WHEELS ON THE VEHICLE

Measure the lateral runout and the radial runout of the front wheels on the vehicle. Go to detailed test C.

● Are the measurements within specifications ?

→ **YES**

Go to **D4**.

→ **NO**

Install new wheels as necessary and Balance the assembly. Test the system for normal operation.

### MEASURE THE LATERAL RUNOUT OF THE FRONT TIRES ON THE VEHICLE

Measure the lateral runout of the front tires on the vehicle. Go to detailed test C.

● Is the runout within specifications ?

→ **YES**

Go to **D5**.

→ **NO**

Install new tires as necessary and Balance the assembly. Test the system for normal operation.

### MEASURE THE RADIAL RUNOUT OF THE FRONT TIRES ON THE VEHICLE



Measure the radial runout of the front tires on the vehicle. Go to detailed test C.

● Is the runout within specifications ?

→ **YES**

Balance the front wheel and tire assemblies. If any tire cannot be balanced, Install a new tire. Test the system for normal operation.

→ **NO**

Go to **D6**.

**MATCH MOUNT THE TIRE AND WHEEL ASSEMBLY**

Mark the high runout location on the tire and also on the wheel. Break the assembly down and rotate the tire 180 degrees (halfway around) on the wheel. Inflate the tire and measure the radial runout.

● Is the runout within specifications ?

→ **YES**

Balance the assembly. Test the system for normal operation.

→ **NO**

If the high spot is not within 101.6mm (4 inches) of the first high spot on the tire, Go to **D7**

**MEASURE THE WHEEL FLANGE RUNOUT**

Dismount the tire and mount the wheel on a wheel balancer. Measure the runout on both wheel flanges. Go to detailed test C.

● Is the runout within specifications ?

→ **YES**

.

→ **NO**

.

**CHECK FOR VIBRATION FROM THE FRONT OF THE VEHICLE**

Spin the front wheel and tire assemblies with a wheel balancer while the vehicle is raised on a hoist. Feel for vibration in the front fender or while seated in the vehicle.

● Is the vibration present ?

→ **YES**

Substitute known good wheel and tire assemblies as necessary. Test the system for normal operation.

→ **NO**

Check the driveline components. Test the system for normal operation.

**DETAILED TEST E : DRIFT LEFT OR RIGHT**

CONDITIONS	DETAILS/RESULTS/ACTIONS
CHECK THE TIRES	

Inspect the tires for excessive wear or damage.

● Are the tires excessively worn or damaged ?

→ **YES**

Install new tires.

→ **NO**

Go to **E2**.

## CHECK THE STEERING LINKAGE

1. Raise and support the vehicle.

2. Check the steering components for indications of excessive wear or damage. See ST group - specification.

● Is there an indication of excessive wear or damage ?

→ **YES**

Repair or Install new components as necessary.

→ **NO**

Go to

## CHECK THE VEHICLE ALIGNMENT

1. Place the vehicle on an alignment rack.

Check the vehicle alignment.

● Is the alignment within specification ?

→ **YES**

Go to

→ **NO**

Adjust the alignment as necessary. See page SS-58 (wheel alignment)

## BRAKE DRAG DIAGNOSIS

Apply the brakes while driving.

● Does drift or pull occur when the brakes are applied ?

→ **YES**

See BR group - specification.

→ **NO**

If the steering wheel is in the center, the vehicle is OK.

## DETAILED TEST F : STEERING WHEEL OFF-CENTER

### CONDITIONS

### DETAILS/RESULTS/ACTIONS

## CHECK THE CLEAR VISION

Place the vehicle on an alignment rack.

● Is the clear vision within specification ?

→ **YES**

.

→ **NO**

Adjust the clear vision to specification.

## INSPECT THE STEERING COMPONENTS

Ebay User ID: reveleus1

1. Raise and support the vehicle.
2. Inspect the steering components for excessive wear or damage. See ST group - specification.
  - Are the steering components excessively worn or damaged ?
    - **YES**  
Repair or Install new components as necessary.
    - **NO**  
If it tracks corectly, vehicle is OK.

## DETAILED TEST G : TRACKS INCORRECTLY

CONDITIONS	DETAILS/RESULTS/ACTIONS
CHECK THE CASTER	
	<p>Place the vehicle on an alignment rack.</p> <ul style="list-style-type: none"><li>● Are the caster within specification ?<ul style="list-style-type: none"><li>→ <b>YES</b> Go to <b>G2</b>.</li><li>→ <b>NO</b></li></ul></li></ul>
CHECK THE REAR SUSPENSION	
	<ol style="list-style-type: none"><li>1. Measure the vehicle wheel base for LH and RH.</li><li>2. Compare the measurements.<ul style="list-style-type: none"><li>● Are the measurements the same ?<ul style="list-style-type: none"><li>→ <b>YES</b> If the ride is smooth, vehicle is OK.</li><li>→ <b>NO</b> Inspect the rear suspension components for wear or damage. Repair or Install new components as necessary. See page SS-44 (rear suspension).</li></ul></li></ul></li></ol>

## DETAILED TEST H : ROUGH RIDE

CONDITIONS	DETAILS/RESULTS/ACTIONS
CHECK THE FRONT SHOCK ABSORBER	

Purchased  
from Ebay seller  
Reveleus1

Thank-you for purchasing from me, it  
is much appreciated.

To contact me please email  
[suzlever@gmail.com](mailto:suzlever@gmail.com)

1. Raise and support the vehicle.
2. Inspect the front shock absorber for oil leaks or damage.
  - Are the tires excessively worn or damaged ?
  - **YES**
  - Install new front shock absorbers.
  - See page SS-28 (front strut assembly).
  - **NO**

**CHECK THE REAR SHOCK ABSORBERS**

- Inspect the rear shock absorbers for oil leaks or damage.
- Are the rear shock absorbers leaking ?
  - **YES**
  - Install new rear shock absorbers.
  - See page SS-45 (rear strut assembly).
  - **NO**

**DETAILED TEST I : EXCESSIVE NOISE**

CONDITIONS	DETAILS/RESULTS/ACTIONS
<b>INSPECT THE SUSPENSION</b>	
	<ol style="list-style-type: none"> <li>1. Raise and support the vehicle.</li> <li>2. Inspect the shock absorber mounting bolts.                             <ul style="list-style-type: none"> <li>● Are the mounting bolts loose or broken ?</li> <li>→ <b>YES</b></li> <li>Tighten or Install new shock absorber mounting bolts.</li> <li>See page SS-28 and SS-45 (front/rear strut assembly).</li> <li>→ <b>NO</b></li> <li>Go to</li> </ul> </li> </ol>
<b>INSPECT THE SPRING AND TORSION BARS</b>	
	<p>Inspect the springs and stabilizer bars for damage.</p> <ul style="list-style-type: none"> <li>● Are the spring or stabilizer bars damaged ?</li> <li>→ <b>YES</b></li> <li>Install new spring and/or stabilizer bars.</li> <li>See page SS-41, SS-55 (front/rear stabilizer bar).</li> <li>→ <b>NO</b></li> </ul>
<b>INSPECT THE FRONT SUSPENSION</b>	

Ebay User ID: reveleus1  
Inspect the front suspension components for excessive wear or damage.

● Are the front suspension components worn or damaged ?

→ **YES**

Install new front suspension components.

See page SS-27 (front suspension).

→ **NO**

.

## DETAILED TEST J : INCORRECT TIRE WEAR

CONDITIONS	DETAILS/RESULTS/ACTIONS
INSPECT THE TIRES	
	<ol style="list-style-type: none"><li>1. Raise and support the vehicle.</li><li>2. Inspect the tires for uneven wear on the inner or outer shoulder.<ul style="list-style-type: none"><li>● Is there uneven tire wear ?</li><li>→ <b>YES</b></li><li>Align the vehicle. Install new tires if badly worn.</li><li>→ <b>NO</b></li><li>Go to</li></ul></li></ol>
UNEVEN TIRE WEAR	
	<p>Inspect the tires for a feathering pattern.</p> <ul style="list-style-type: none"><li>● Do the tires have a feathering pattern ?</li><li>→ <b>YES</b></li><li>Align the vehicle. Install new tires if badly worn.</li><li>→ <b>NO</b></li><li>.</li></ul>
CHECK FOR CUPPED TIRE	
	<p>Inspect the tires for cupping or dishing.</p> <ul style="list-style-type: none"><li>● Are the tires cupped or dished ?</li><li>→ <b>YES</b></li><li>Balance and Rotate the tires.</li><li>→ <b>NO</b></li><li>.</li></ul>

## DETAILED TEST K : VIBRATION

CONDITIONS	DETAILS/RESULTS/ACTIONS
ROAD TEST	

Accelerate the vehicle to the speed at which the customer indicated the vibration occurred.

● Is the vibration present ?

→ **YES**

.

→ **NO**

The vehicle is OK. Go to **TROUBLESHOOTING**.

## INSPECT THE TIRES

1. Raise and support the vehicle with a frame contact hoist.

2. Inspect the tires for extreme wear or damage, cupping, or flat spots.

● Are the tires OK ?

→ **YES**

.

→ **NO**

Check the suspension components for misalignment, abnormal wear, or damage that may have contributed to the tire wear.

Correct the suspension concerns and Install new tires.

## INSPECT THE WHEEL BEARINGS

Spin the tires by hand to check for wheel bearing roughness.

● Is the front wheel bearing OK ?

→ **YES**

.

→ **NO**

Install new front wheel bearings as necessary.

See DS group - front axle.

## TIRE/WHEEL BALANCE

Check the tire/wheel balance.

● Are the tires balanced ?

→ **YES**

Go to **K5**.

→ **NO**

Balance the tires and wheels as necessary.

## MEASURE THE RUNOUTS

For each wheel position measure, locate and mark the following items.

See page SS-58 (wheel/tire).

- High point of the tire/wheel assembly total radial runout
- High point of the wheel radial runout
- High point of the wheel lateral runout

● Are the runouts as specified ?

→ **YES**

Go to **K7**.

→ **NO**

Go to **K6**.

**SUBSTITUTE THE WHEELS AND TIRE**

1. Substitute a known good set of wheels and tires.
2. Carry out a road test.
3. If the vehicle still exhibits a shake or vibration, note the vehicle speed and/or engine rpm which it occurs.

● Is the vibration felt ?

→ **YES**

Engine/transmission imbalance.

See the specification of TR group, EM group, FL group and EC group.

→ **NO**

Install the original tire/wheel assemblies one by one, Road testing at each step until the damaged tire(s)/wheel(s) as necessary. Test the system for normal operation.

Wheel /tire noise, vibration and harshness concerns are directly related to vehicle speed and are not generally affected by acceleration, coasting or decelerating. Also, out-of-balance wheel and tires can vibrate at more than one speed. A vibration that is affected by the engine rpm, or is eliminated by placing the transmission in Neutral is not related to the tire and wheel. As a general rule, tire and wheel vibrations felt in the steering wheel are related to the front tire and wheel assemblies. Vibrations felt in the seat or floor are related to the rear tire and wheel assemblies. This can initially isolate a concern to the front or rear.

Careful attention must be paid to the tire and wheels. There are several symptoms that can be caused by damaged or worn tire and wheels. Carry out a careful visual inspection of the tires and wheel assemblies. Spin the tires slowly and watch for signs of lateral or radial runout. Refer to the tire wear chart to determine the tire wear conditions and actions.

**WHEEL AND TIRE DIAGNOSIS**

Rapid wear at the center

Rapid wear at both shoulders

Wear at one shoulder

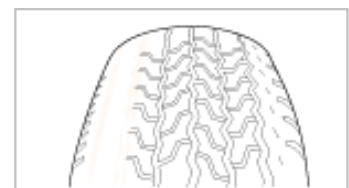
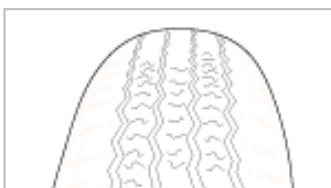



- Center- tread down to fabric due to excessive over inflated tires
- Lack of rotation
- Excessive toe on drive wheels
- Heavy acceleration on drive

- Underinflated tires
- Worn suspension components
- Excessive cornering speeds
- Lack of rotation

- Toe adjustment out of specification
- Camber out of specification
- Damaged strut
- Damaged lower arm

### WHEEL AND TIRE DIAGNOSIS

Partial wear

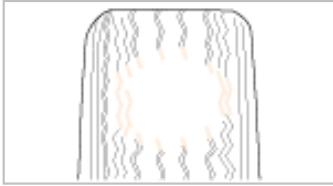

- Cansed by irrequal burrs on brak drums.

Feather edges wheels



- Toe adjustment out of specification
- Damaged or worn tie rods
- Damaged knuckle

Wear pattern



- Excessive toe on non-drive wheels
- Lack of rotation