

EMISSION CONTROL SYSTEM

Return to Main Table of Contents

GENERAL	2.
CRANKCASE EMISSION SYSTEM	9
EVAPORATIVE EMISSION SYSTEM	10
EXHAUST EMISSION SYSTEM	14

GENERAL SPECIFICATIONS

Components	Function	Remarks
Crankcase Emission Control System Positive crankcase ventilation (PCV) valve	HC reduction	Variable flow rate type
Evaporative Emission Control System EVAP Canister EVAP Canister Purge Solenoid Valve	H C r e d u c t i o n	ON/OFF solenoid valve
Exhaust Emission Control System MFI system (air-fuel mixture control device) Three-way catalytic converter Exhaust gas recirculation system EGR valve EGR TVV (Except California)	CO, HC, NOx reduction CO, HC, NOx reduction NOx reduction	Oxygen sensor feedback type Monolith type Single type Bimetal type

EGR TVV : Exhaust Gas Recirculation Thermal Vacuum Valve

EVAP : Evaporative Emission

MFI : Multiport Fuel Injection

SERVICE STANDARD

EVAP Canister Purge Solenoid Valve Coil resistance	36-44 Ω [at 20°C (68°F)]
EGR TVV temperature Opening temperature Closing temperature	MIN.50°C(122°F) 61-69°C (142-156°F)
EGR temperature sensor (California only) Coil resistance	60-83 k Ω [at 50°C (122°F)] 11-14 k Ω [at 100°C (212°F)]
EGR solenoid valve (California only) Coil resistance	36-44 Ω [at 20°C (68°F)]

TIGHTENING TORQUE

	Nm	kg.cm	lb.ft
Positive crankcase ventilation valve	8-12	80-120	6-8
EGR valve installation bolt	15-22	150-220	11-16
EGR TVV	20-40	200-400	14-29
EGR temperature sensor	10-12	100-120	7-9

SEALANT

EGR TVV thread portion	Three bond 1104 or equivalent
------------------------	-------------------------------

TROUBLESHOOTING

Symptom	Probable cause	Remedy
Engine will not start or hard to start	Vacuum hose disconnected or damaged The EGR valve is not closed Malfunction of the EVAP Canister Purge Solenoid Valve	Repair or replace Repair or replace Repair or replace
Rough idle or engine stalls	The EGR valve is not closed Vacuum hose disconnected or damaged Malfunction of the PCV valve Malfunction of the EVAP Canister Purge system	Repair or replace Repair or replace Replace Check the system; if there is a problem, check its component parts
- Engine hesitates or poor acceleration	Malfunction of the exhaust gas recirculation system	Check the system; if there is a problem, check its component parts
Excessive oil consumption	Positive crankcase ventilation line clogged	Check positive crankcase ventilation system
Poor fuel mileage	Malfunction of the exhaust gas recirculation system	Check the system; if there is a problem, check its component parts

EMISSION CONTROLS LOCATION

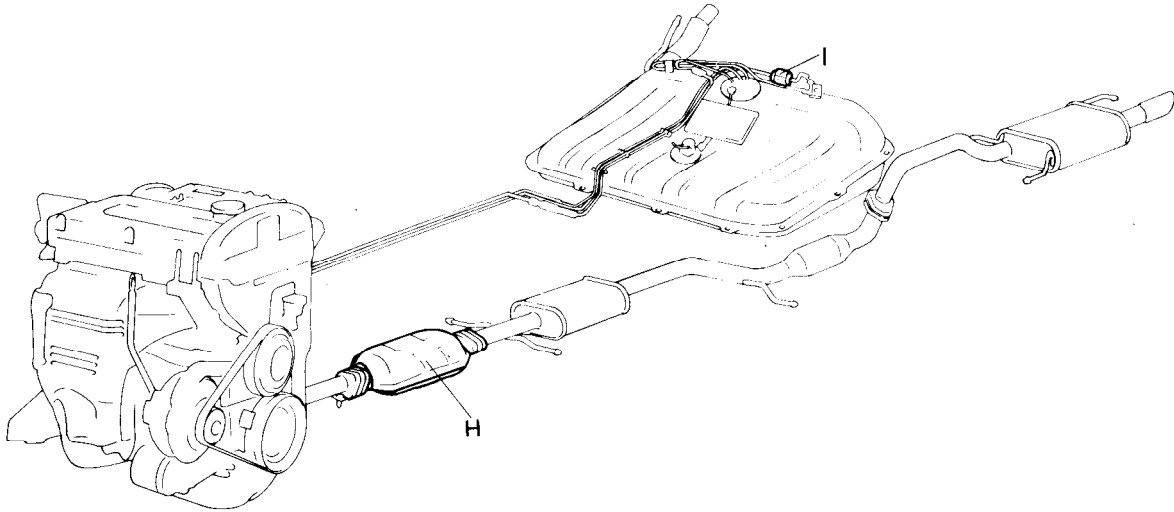
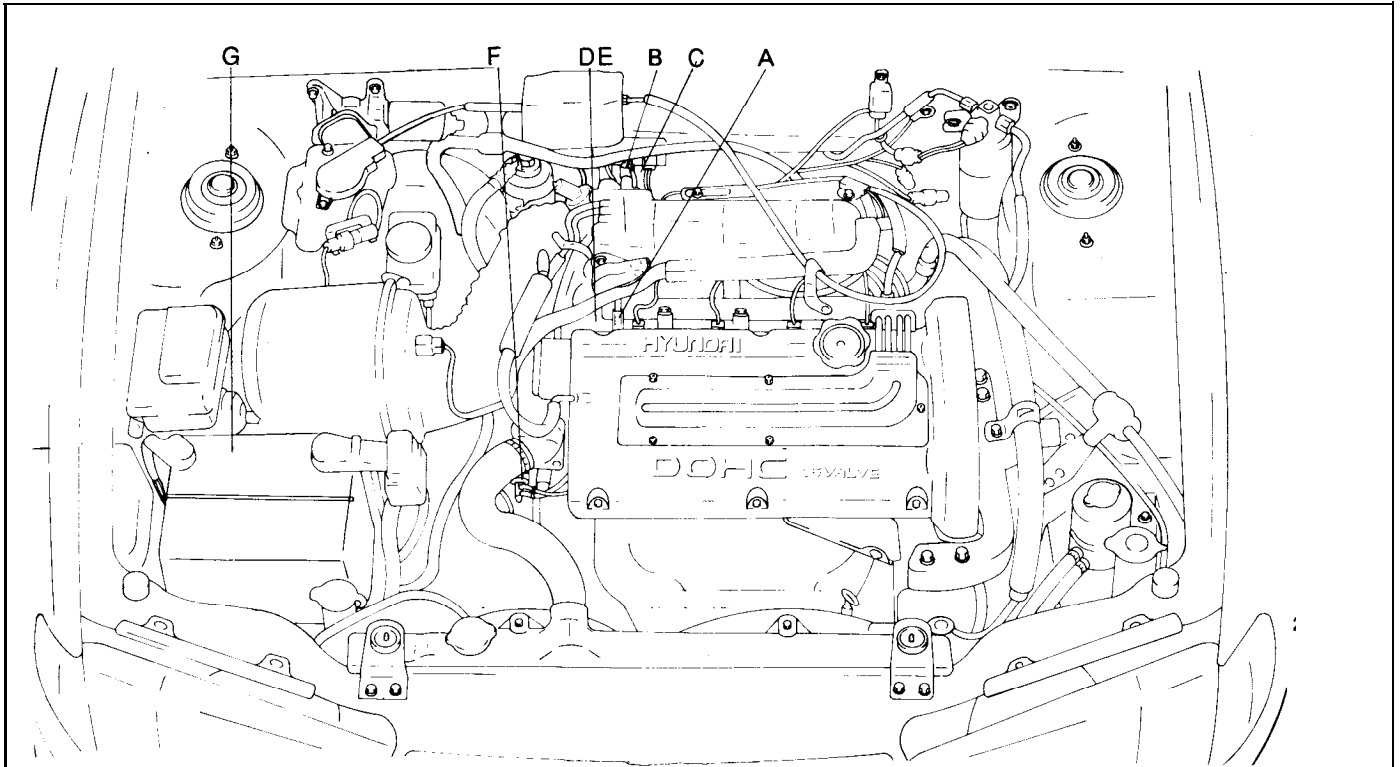

- A. PCV valve
- B. EVAP Canister Purge Selenoid Valve
- C. EGR selenoid valve (California only)
- D. EGR valve
- E. EGR temperature sensor (California only)
- F. EGR TVV
- G. EVAP Canister
- H. Catalytic converter
- I. Two-way valve

rescan 29-5; upside down

VACUUM HOSES LAYOUT
[Except California]

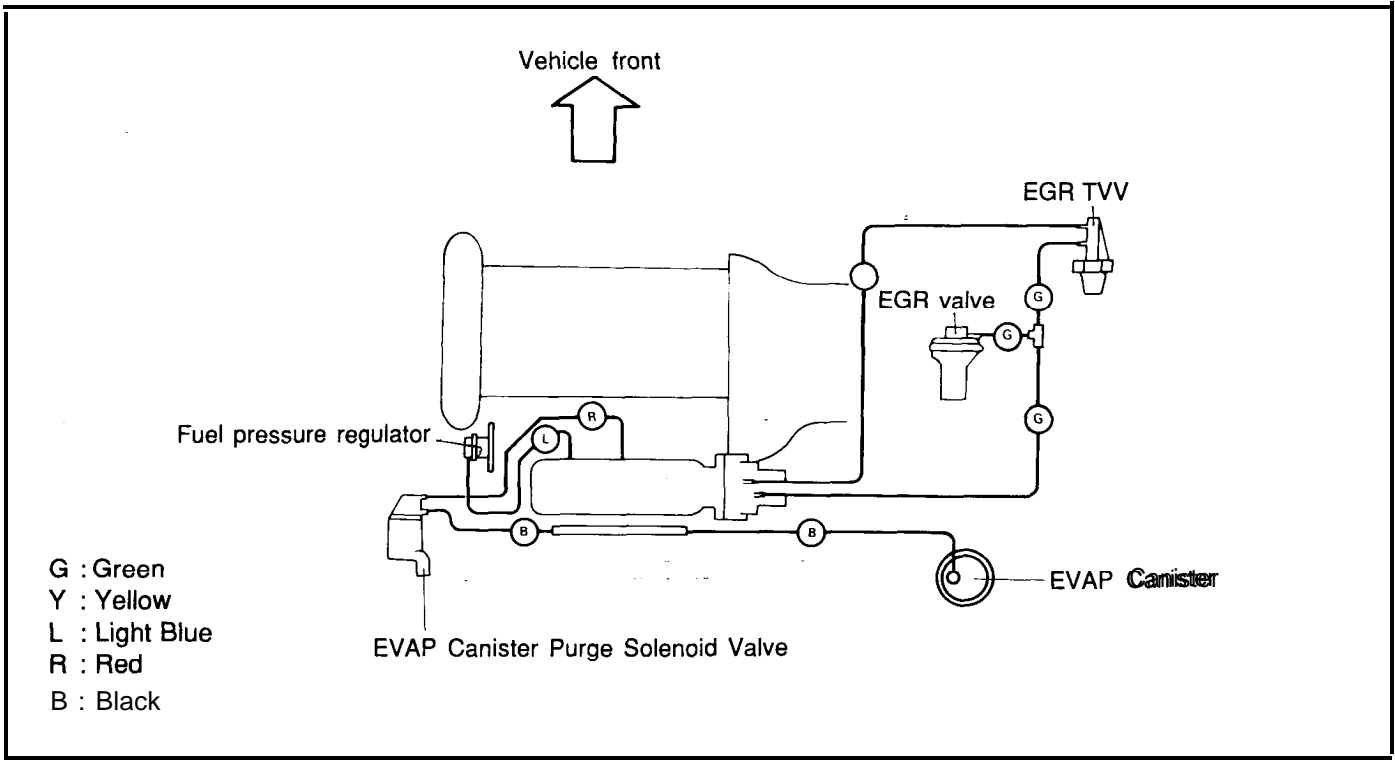

[California only]

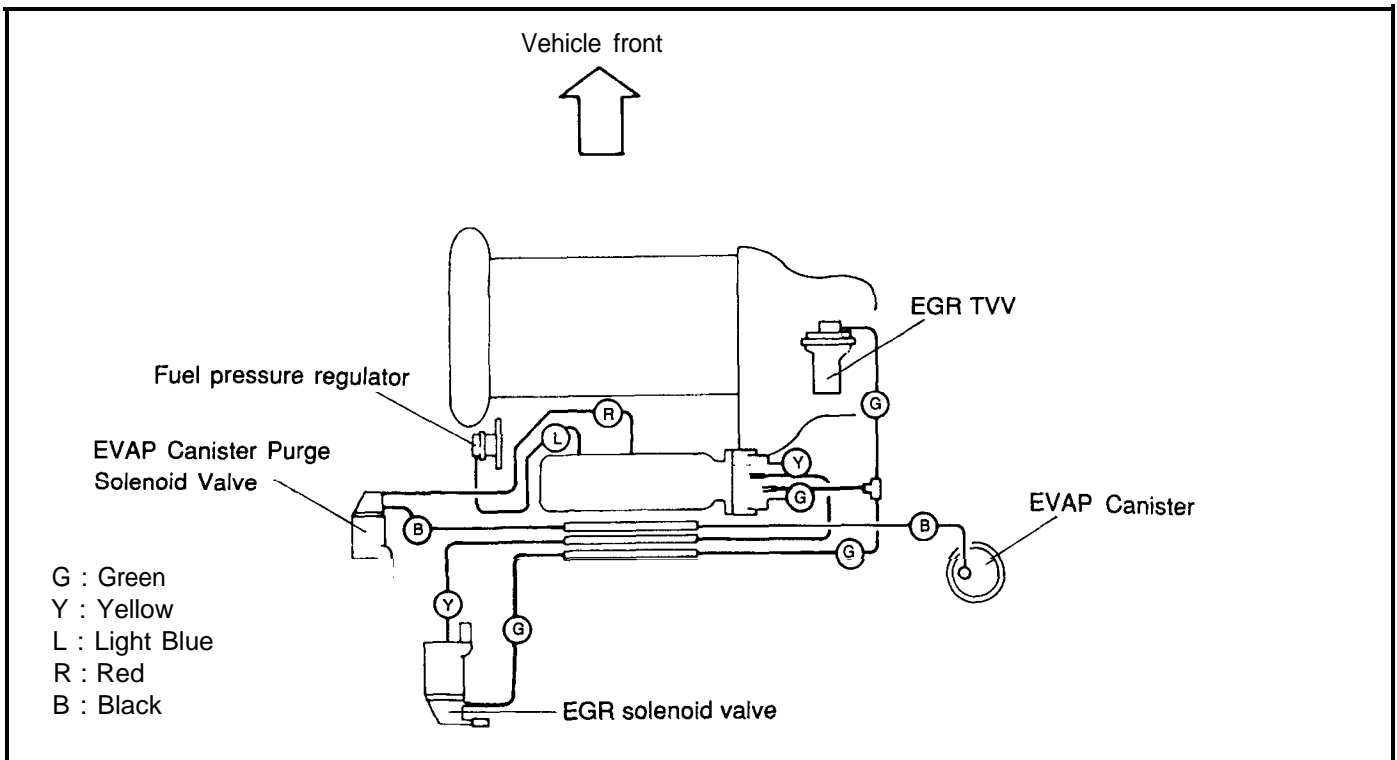

SCHEMATIC DRAWING (Except California)

- *1 HEATED OXYGEN SENSOR
- *2 VOLUME AIR FLOW SENSOR
- *3 INTAKE AIR TEMP. SENSOR
- *4 THROTTLE POSITION SENSOR
- *5 IDLE SWITCH
- *6 CAMSHAFT POSITION SENSOR
- *7 CRANKSHAFT POSITION SENSOR
- *8 BAROMETRIC PRESSURE SENSOR
- *9 EGR TEMP. SENSOR
- *10 ENGINE COOLANT TEMP. SENSOR
- o STARTER "S" TERMINAL
- o BATTERY VOLTAGE
- o VEHICLE SPEED SENSOR
- o COOLER LOAD SIGNAL
- o "N" SWITCH (A/T ONLY)
- o POWER STEERING SWITCH
- o CRANKING SIGNAL



- *1 INJECTOR
- *2 IGNITION COIL
- *3 ISC MOTOR
- *4 EVAP CANISTER PURGE SOLENOID VALVE
- o FUEL PUMP CONTROL
- o CONTROL RELAY
- o COOLER RELAY
- o IGNITION TIMING CONTROL
- o DIAGNOSIS

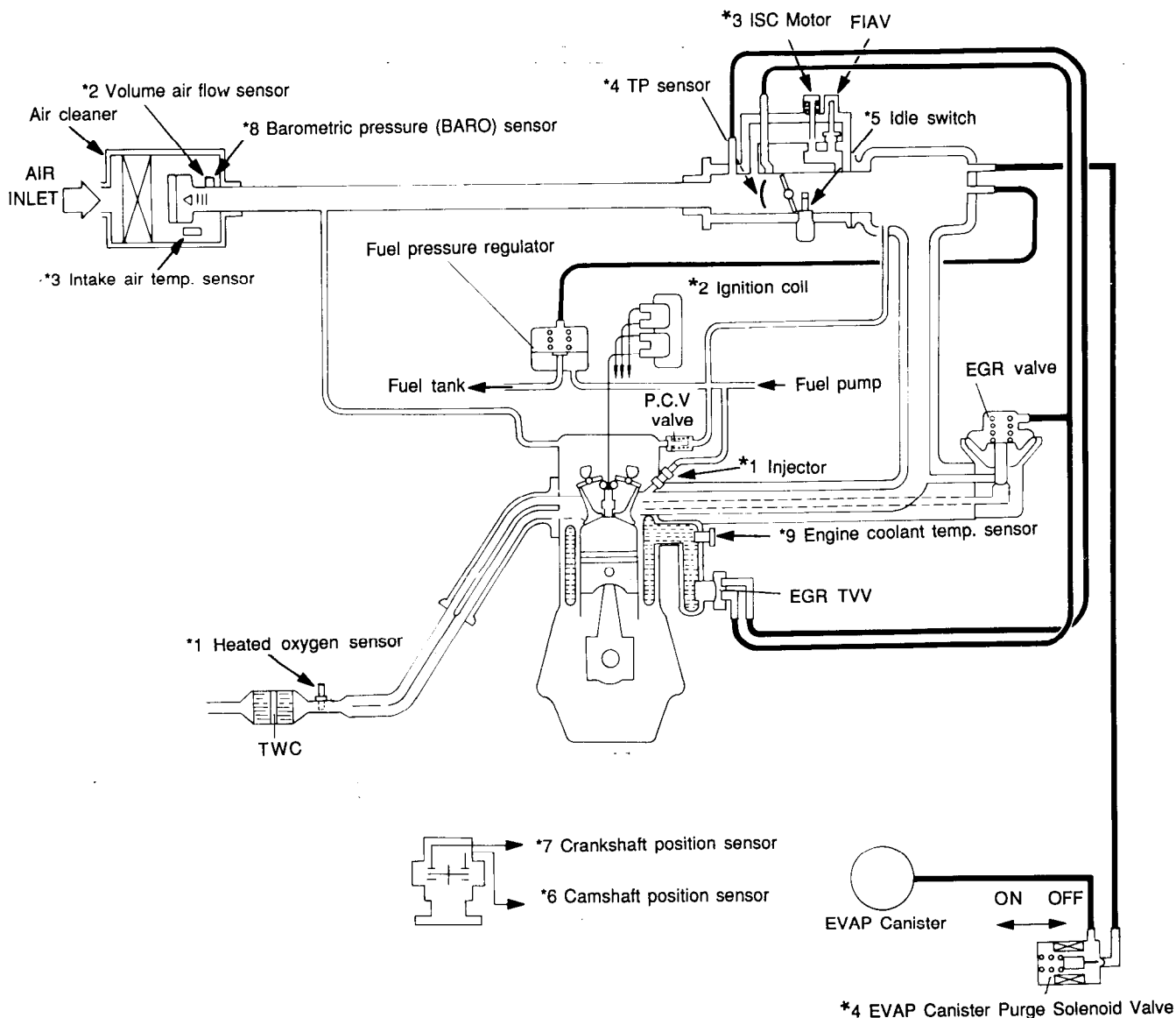

TWC : Three Way Catalytic Converter

*4 EVAP Canister Purge Solenoid Valve

SCHEMATIC DRAWING (California only)

- *1 HEATED OXYGEN SENSOR (FR, RR;
- *2 VOLUME AIR FLOW SENSOR
- *3 INTAKE AIR TEMP. SENSOR
- *4 THROTTLE POSITION SENSOR
- *5 CAMSHAFT POSITION SENSOR
- *6 CRANKSHAFT POSITION SENSOR
- *7 BAROMETRIC PRESSURE SENSOR
- *8 EGR TEMP. SENSOR
- *9 ENGINE COOLANT TEMP. SENSOR
- *10 IDLE SWITCH
 - o STARTER "S" TERMINAL
 - o BATTERY VOLTAGE
 - o VEHICLE SPEED SENSOR
 - o COOLER LOAD SIGNAL
 - o "N" SWITCH (A/T ONLY)
 - o POWER STEERING SWITCH



- *1 INJECTOR
- *2 IGNITION COIL
- *3 ISC MOTOR
- *4 EVAP CANISTER PURGE SOLENOID VALVE
- *5 EGR SOLENOID VALVE
 - o FUEL PUMP CONTROL (CONTROL RELAY)
 - o COOLER RELAY
 - o IGNITION TIMING CONTROL
 - o DIAGNOSIS

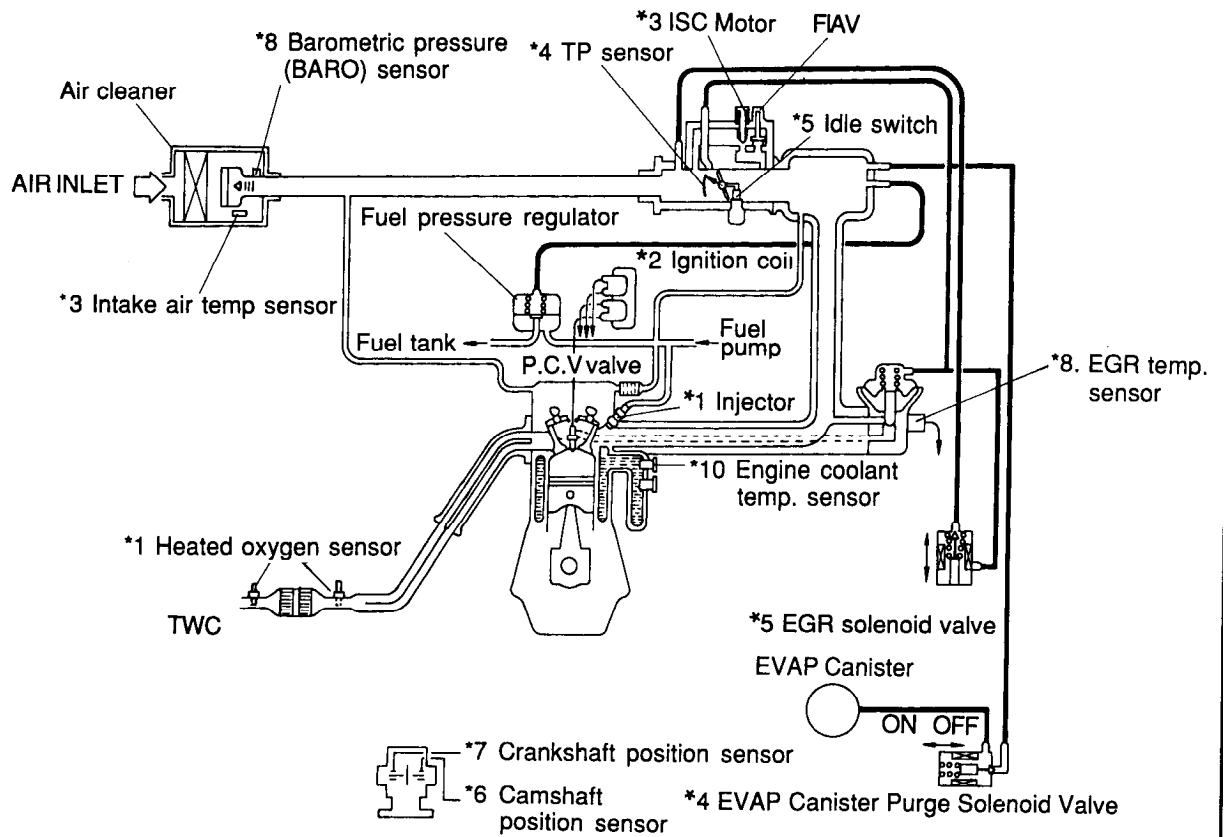

TWC : Three Way Catalytic Converter

CRANKCASE EMISSION SYSTEM

1. Disconnect the ventilation hose from the positive crankcase ventilation (PCV) valve. Remove the PCV valve from the rocker cover and reconnect it to the ventilation hose.
2. Run the engine at idle and put a finger on the open end of the PCV valve and make sure that intake manifold vacuum is felt.

NOTE

The plunger inside the PCV valve will move back and forth.

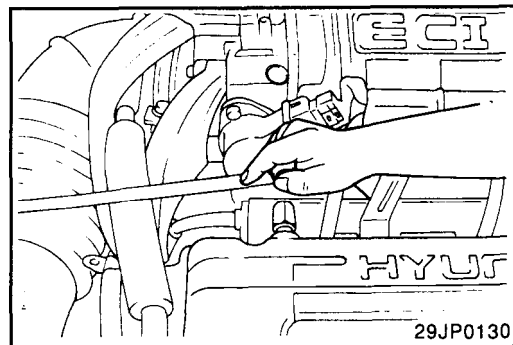

3. If vacuum is not felt, clean the PCV valve and ventilation hose in cleaning solvent or replace if necessary.

INSPECTION

1. Remove the positive crankcase ventilation valve.
2. Insert a thin stick into the positive crankcase ventilation valve from the threaded side to check that the plunger moves.
3. If the plunger does not move, the positive crankcase ventilation valve is clogged. Clean it or replace.

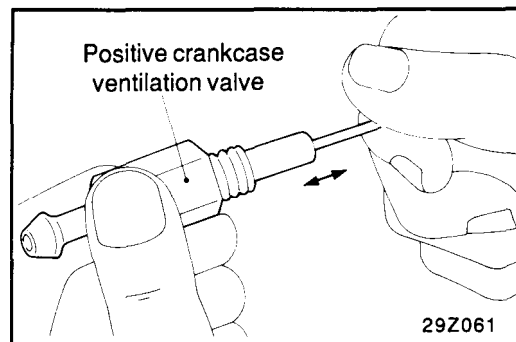

INSTALLATION

Install the positive crankcase ventilation valve and tighten to the specified torque.

PCV valve tightening torque 8-12Nm(80-120kg.cm,6-8lb.ft)

EVAPORATIVE EMISSION SYSTEM

COMPONENTS

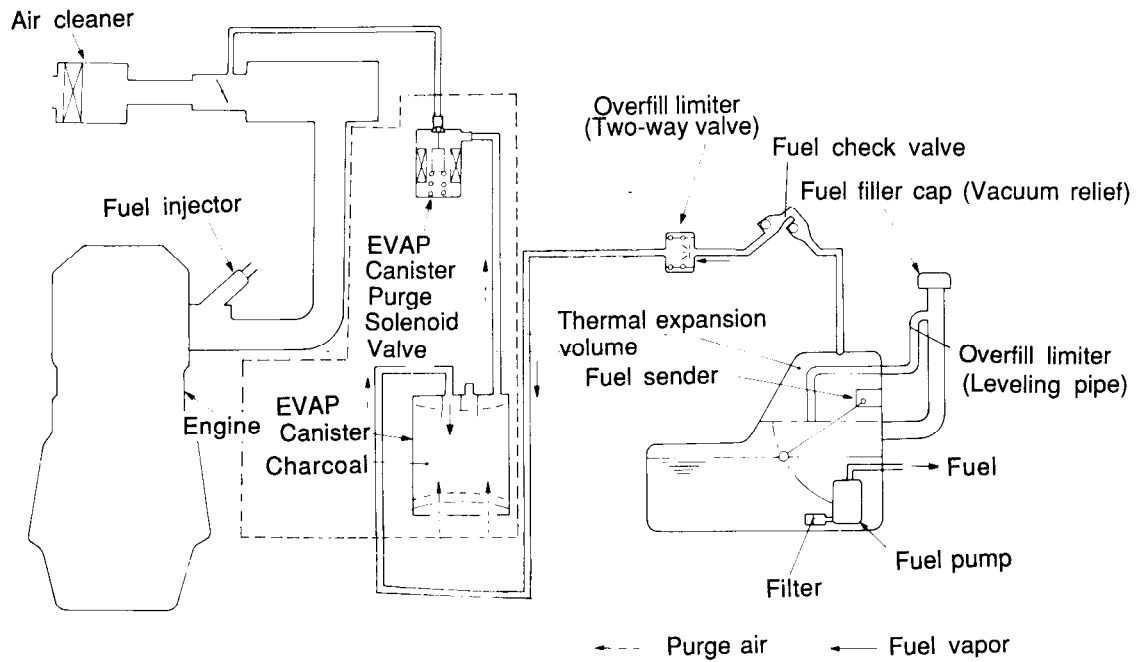

EVAP : Evaporative Emission

EVAP CANISTER

Inspection

1. Look for loose connections, sharp bends or damage to the fuel vapor lines.
2. Look for distortion, cracks or fuel leakage.
3. After removing the EVAP Canister, inspect for cracks or damage.

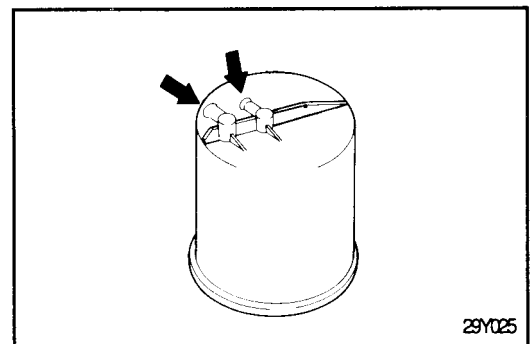

EVAP CANISTER PURGE SOLENOID VALVE

Inspection

NOTE

When disconnecting the vacuum hose, make an identification mark on it so that it can be reconnected to its original position.

1. Disconnect the vacuum hose (black with red stripe) from the solenoid valve.
2. Detach the harness connector.
3. Connect a vacuum pump to the nipple to which the red-striped vacuum hose was connected.

4. Apply vacuum and check when voltage is applied to the purge-control solenoid valve and when the voltage is discontinued.

Battery voltage	Normal condition
When applied	Vacuum is released.
When discontinued	Vacuum is maintained

5. Measure the resistance between the terminals of the solenoid valve.

EVAP Canister Purge Solenoid Valve	
Coil resistance	36-44Ω[at 20°C(68°F)]

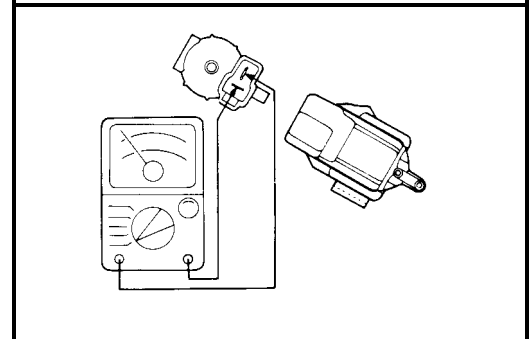
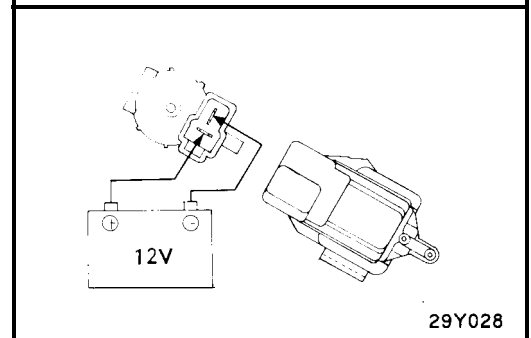
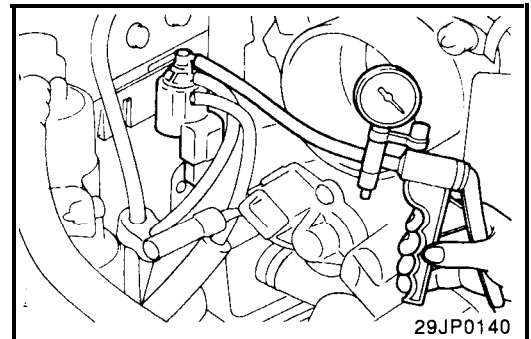

OVERFILL LIMITER (TWO-WAY VALVE)

To inspect the overfill limiter (Two-way valve), refer to Group 31-Fuel tank.

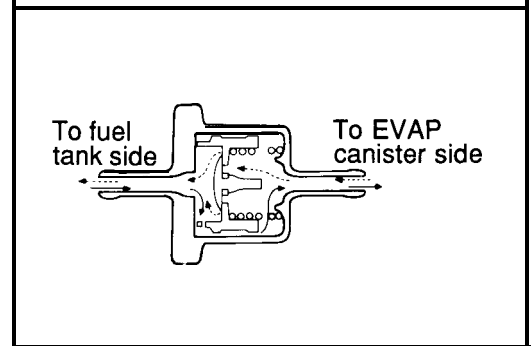

FUEL FILLER CAP

Check the gasket of the fuel filler cap, and the filler cap itself, for damage or deformation; replace the cap if necessary.

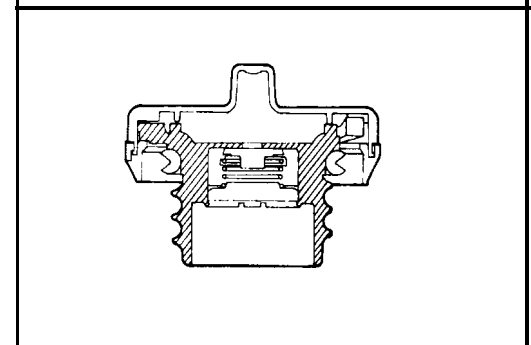

CHECKING PURGE SYSTEM

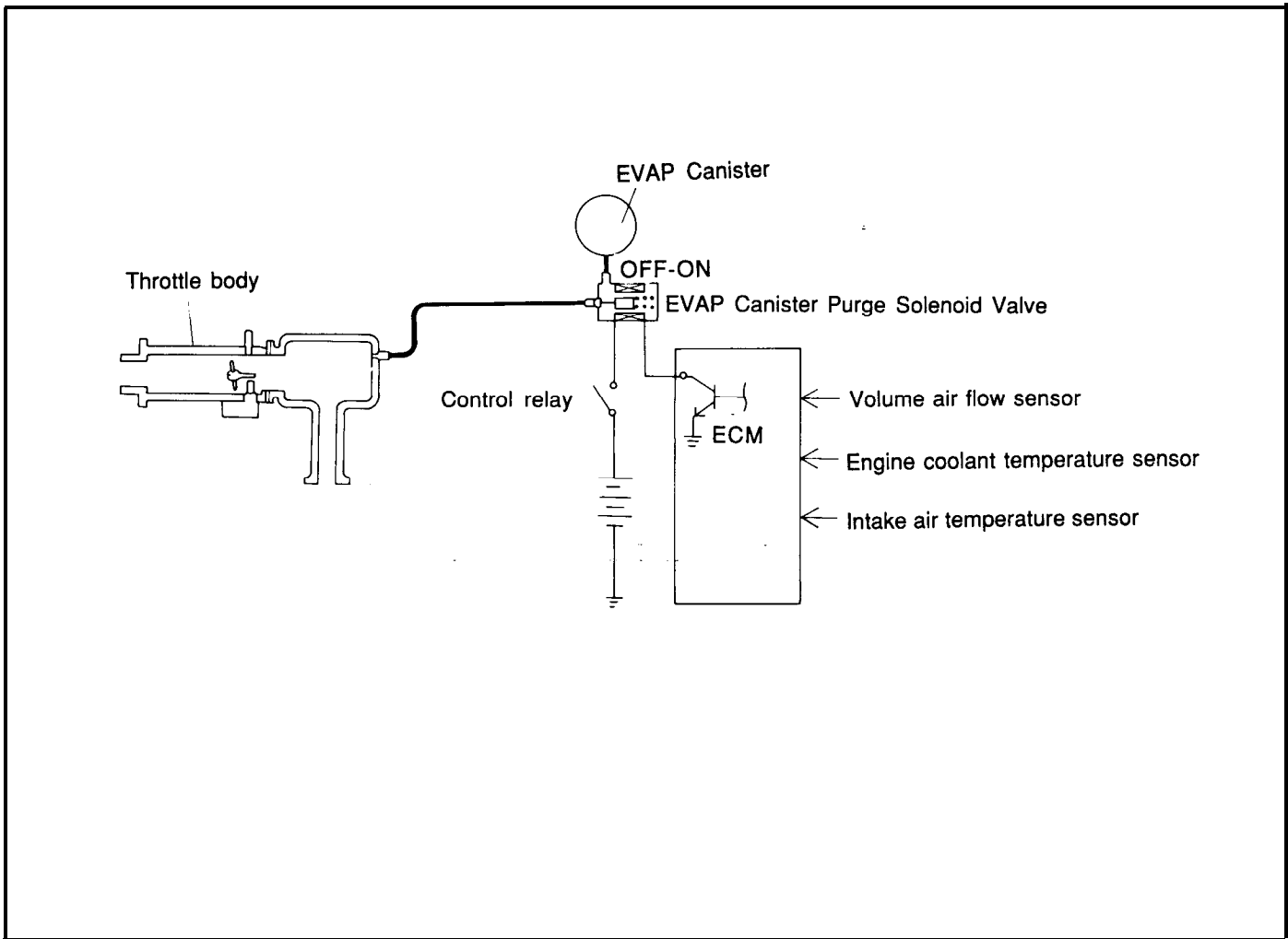

Checking

1. Disconnect the vacuum hose (red stripe) from the throttle body, and connect a vacuum pump to the vacuum hose.
2. Check the following points when the engine is cold [engine coolant temperature 60°C (140°F) or below] and when it is warm [engine coolant temperature 70°C (158°F) or higher].

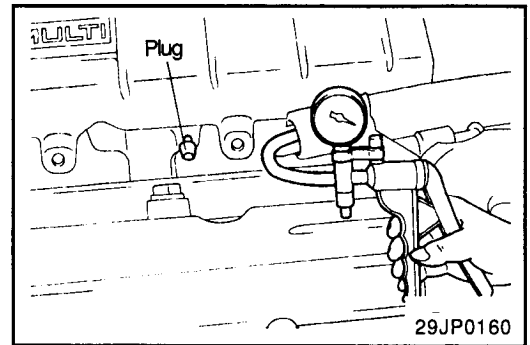

When engine is cold

Engine operating condition	Applying vacuum	Result
Idling	50 kPa (7.3 psi)	Vacuum is held
3,000rpm		

When engine is warm

Engine operating condition	Aply vacuum	Result
Idling	50 kPa (7.3 psi)	Vacuum is held
Within 3 minutes after engine start 3,000 rpm	Try to apply vacuum	Vacuum is released
After 3 minutes have passed after engine start 3,000 rpm	50 kPa (7.3 psi)	Vacuum will be held momentarily, after which, it will be released. NOTE The vacuum will leak continuously if the altitude is 2,200 m (7,200 ft.) or higher, or the intake air temperature is 50°C (122°F) or lower.

PURGE PORT VACUUM

Inspection

Engine coolant temperature: 80-95°C (176-205°F)

1. Disconnect the vacuum hose from the intake manifold purge hose nipple and connect a hand vacuum pump to the nipple.

2. Start the engine and check to see that, after raising the engine speed by racing the engine, vacuum remains fairly constant.

NOTE

If there is no vacuum created, it is possible that the intake manifold port may be clogged and require cleaning.

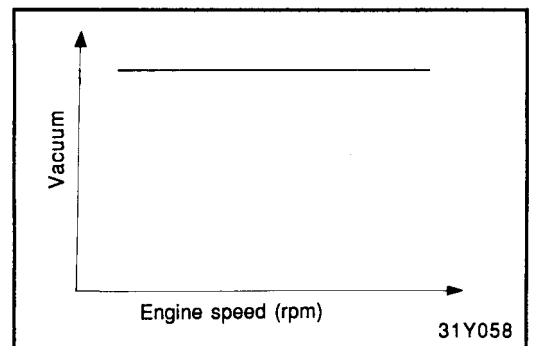
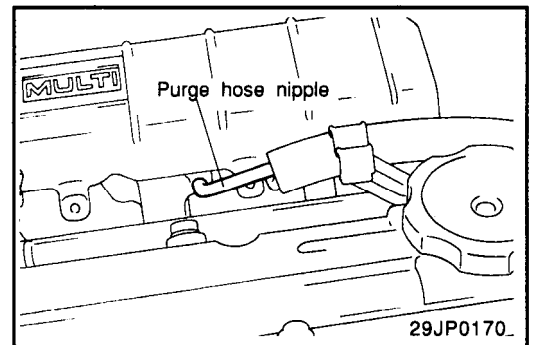

EXHAUST EMISSION SYSTEM

Exhaust emissions (CO, HC, NOx) are controlled by a combination of engine modifications and the addition of special control components.

Modifications to the combustion chamber, intake manifold, camshaft and ignition system form the basic control system. Additional control devices include an exhaust gas recirculation (EGR) system and catalytic converters.

These systems have been integrated into a highly effective system which controls exhaust emissions while maintaining good driveability and fuel economy.

AIR/FUEL MIXTURE RATIO CONTROL SYSTEM

[Multport Fuel Injection (MFI) System]

The MFI system is a system which employs the signals from the oxygen sensor to activate and control the injector installed in the manifold for each cylinder, thus precisely regulating the air/fuel mixture ratio and reducing emissions.

This in turn allows the engine to produce exhaust gases of the proper composition to permit the use of a three-way catalyst. The three-way catalyst is designed to convert the three pollutants (1) hydrocarbons (HC), (2) carbon monoxide (CO), and (3) oxides of nitrogen (NOx) into harmless substances. There are two operating modes in the MFI system.

1. Open-Loop air/fuel ratio is controlled by information programmed into the ECM.
2. Closed-Loop air/fuel ratio is varied by the ECM based on information supplied by the oxygen sensor.

EXHAUST GAS RECIRCULATION SYSTEM

Inspection (Except California)

1. Disconnect the vacuum hose (green stripe) from the throttle body, and connect a vacuum pump to the vacuum hose.
2. Check the following points when the engine is both cold [engine coolant temperature 50°C (122°F) or below] and hot [engine coolant temperature 80-95°C (176-205°F) or higher].

Engine coolant temperature	Vacuum	Engine condition	Normal condition
Cold	APPLY	Idling	Vacuum is released
Hot	6 kPa (1.7in.Hg)	Idling	Vacuum is held
	26 kPa (7.5 in.Hg)	Idle is unstable	Vacuum is held

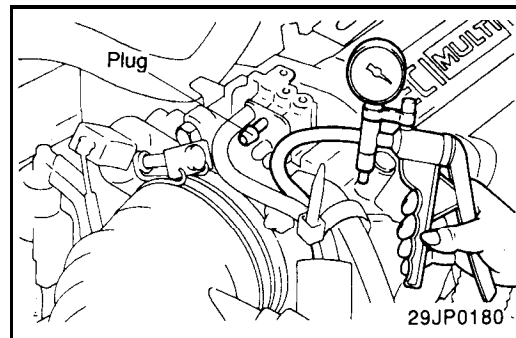

Inspection (California Only)

1. Disconnect the vacuum hose (green stripe) from the EGR valve body, and connect a vacuum pump via the three way terminal.
2. Check the following points when the engine is both cold [engine coolant temperature 20°C (68°F) or below] and hot [engine coolant temperature 70°C (158°F) or higher].

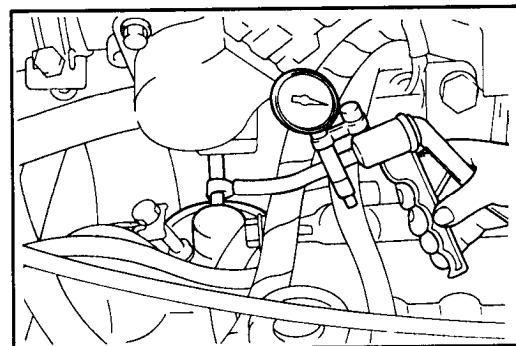

[When the engine is cold]

Engine condition	Normal condition
Rev engine	No change in vacuum (atmospheric pressure)

[When the engine is warm]

Engine condition	Normal condition
Rev engine	Vacuum rises temporarily to 14 kPa (3.9 in.Hg) or more.

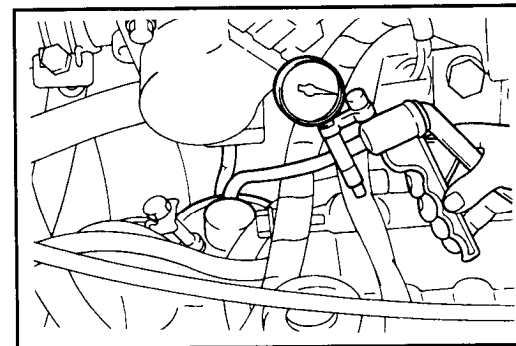

3. Disconnect the three-way terminal and connect the hand vacuum pump directly to the Exhaust Gas Recirculation (EGR) valve.
4. Check whether the engine stalls or the idling is unstable when a vacuum of 26 kPa (7.5 in.Hg) or higher is applied during idling.

EGR VALVE VACUUM

Inspection

Engine coolant temperature: 80-95°C (176-205°F)

1. Disconnect the vacuum hose from the throttle body EGR vacuum nipple and connect a hand vacuum pump to the nipple.

2. Start the engine and check to see that, after raising the engine speed by racing the engine, E vacuum rises proportionately with the rise in engine speed.

NOTE

If there is a problem with the change in vacuum, it is possible that the throttle body E port may be clogged and require cleaning.

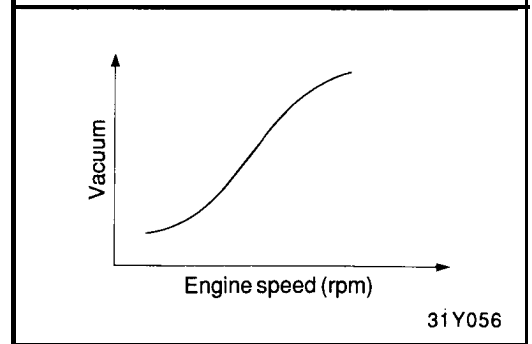
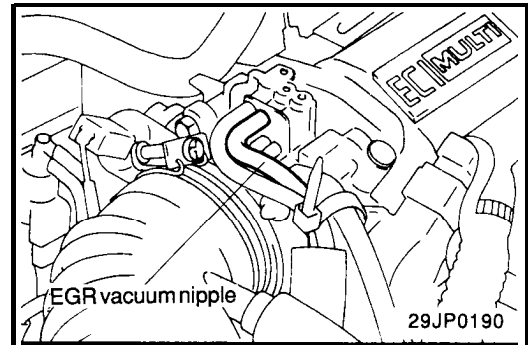

EGR VALVE

1. Remove the EGR valve and check for sticking, carbon deposits, etc.
If such conditions exist, clean with solvent to ensure tight valve seat contact.
2. Connect a manual vacuum pump to the EGR valve.
3. Apply a vacuum of 67 kPa (9.7 psi) and check air tightness.
4. Blow in air from one passage of the EGR to check condition as follows.

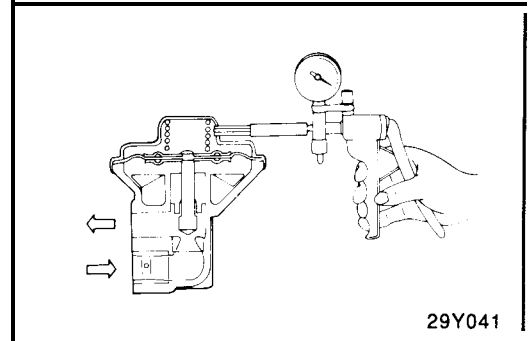

Vacuum	Normal condition
7 kPa (1.0 psi) or less	Air does not blow through
23 kPa (3.3 psi) or more	Air blows through

When installing the EGR valve, use a new gasket and tighten to the specified torque.

Tightening torque

EGR valve
15-22 Nm (150-220 kg.cm, 11-16 lb.ft)

Exhaust Gas Recirculation Thermal Vacuum Valve [(EGR TVV) Except California]

CAUTION

1. Do not use a wrench on the plastic section when removing or installing the EGR TVV.
2. When installing, apply a coat of sealant to the threads, and tighten to the specified torque.

Tightening torque
 EGR TVV 20-40 Nm (200-400 kg.cm, 14-29 lb.ft)

3. When disconnecting the vacuum hose, make an identification mark on it so that it can be reconnected to the original position.

1. Disconnect the vacuum hoses from the EGR TVV, and connect a manual vacuum pump to the EGR TVV.
2. Apply a vacuum and check the air passage through the-EGR TVV.

Engine coolant temperature	Normal condition
50°C (122°F) or less	Vacuum leaks
80°C (176°F) or more	Vacuum is maintained

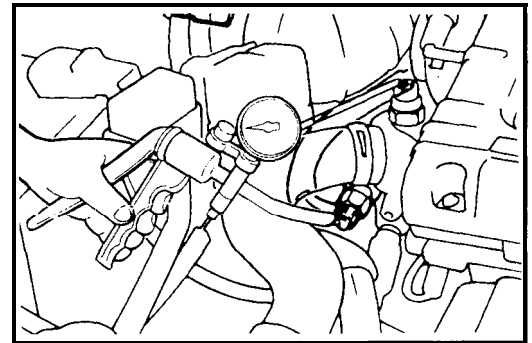

EGR Temperature Sensor (California only)

1. Place the EGR temperature sensor in water, and then measure the resistance value between terminals 1 and 2 while increasing the water temperature.
 If out of specification, replace the EGR temperature sensor.

Temperature °C (°F)	Resistance (kΩ)
50(122)	60-83
100(212)	11-14

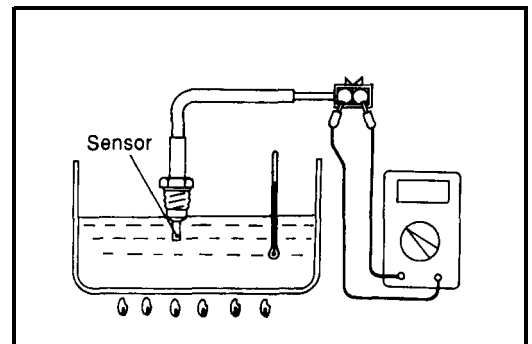

EGR Control Solenoid Valve (California only)

NOTE

When disconnecting the vacuum hose, make an identification mark on it so that it can be reconnected to its original position.

1. Disconnect the vacuum hose (green stripe) from the solenoid valve.
2. Disconnect the harness connector.
3. Connect a hand vacuum pump to the nipple to which the green-striped vacuum hose was connected.

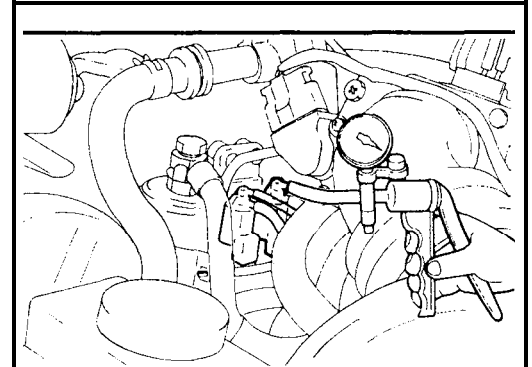

4. Apply a vacuum to check for a maintained vacuum when voltage applied directly to the EGR solenoid valve.
When the voltage is discontinued, the vacuum is released.

Battery voltage	Result
When applied	Vacuum is held.
When discontinued	Vacuum is released

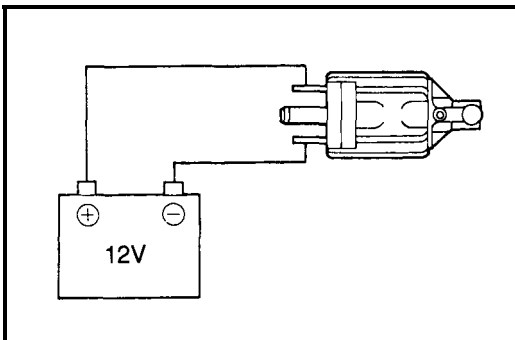

5. Measure the resistance between the terminals of the solenoid valve.

Standard value 36-44 Ω [at 20°C (68°F)]

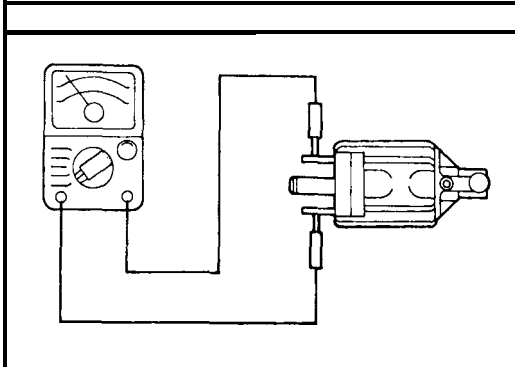

CATALYTIC CONVERTER

INSPECTION

Inspect for damage, cracking or deterioration. Replace if faulty.

CAUTION

The catalytic converters require the use of unleaded gasoline only. Leaded gasoline will destroy the effectiveness of the catalysts as an emission control device.

Under normal operating conditions, the catalytic converters will not require maintenance. However, it is important to keep the engine properly tuned. Engine misfiring may cause overheating of the catalysts. This may cause heat damage to the converters or vehicle components. The situation can also occur during diagnostic testing if any spark plug cables are removed and the engine is allowed to idle for a prolonged period of time.

